

VST Installation Procedure for ENVIRO-LOC™ ECO Diesel NPNF Nozzle Repair Kit (No Pressure No Flow)

Part Number Series:
VST-NSA-700 (Spout Assembly)



Vapor Systems Technologies, Inc.
650 Pleasant Valley Drive
Springboro, Ohio 45066 (USA)
Toll Free: 1-888-878-4673
Phone: 937-704-9333
Fax: 937-704-9443
www.vsthose.com

**USE ONLY ON VST NOZZLES:
VST-DS-NP(CC) AND VST-DS-NP(CC)R
CC = COLOR – SEE LIST PRICE SCHEDULE**

TOOLS

- VST-SRT-200 Spout Nut Torque Wrench Attachment
- Wide Mouth Funnel
- Petroleum Jelly (or suitable lubricant)
- Approved Fuel Container
- Loctite® 271
- Torque Wrench

GENERAL INFORMATION

If hanging hardware components are involved in a drive-off or incur other customer abuse, each individual component must be functionally tested prior to customer dispensing activities.

INSTALLATION PREPARATION

These procedures must be followed to ensure leak-proof installation and operation of these nozzles.

1. Turn off and tag the power to the dispenser. Dispenser must be de-energized prior to service to avoid personal injury.
2. Barricade work area to block vehicle access to the dispenser.
3. Close dispenser shear valve prior to removing hanging hardware (hoses, safety breakaways, and nozzles).
4. Visually inspect and assess the extent of damage to all hanging hardware components. If the spout is loose at all, replace the VST-NSA-700 spout assembly.
5. Drain liquid product from the hanging hardware set into an approved container prior to replacing any hanging hardware component:
 - a. Relieve line pressure by pulling the nozzle lever.
 - b. Remove the nozzle while holding the backend of the nozzle and the hose over an approved container to drain any remaining liquid from the hanging hardware set.
6. Remove hanging hardware from the dispenser prior to making replacement component assembly connections. VST recommends connecting the whip hose to the dispenser as the last connection during hanging hardware assembly.

NOZZLE SPOUT ASSEMBLY REMOVAL (See Figure 1)

1. Remove splash guard if present.
2. Loosen spout nut with VST-SRT-200 Spout Nut Torque Wrench Attachment.

NOTE: Do not use a pipe wrench or locking-type pliers.

3. Once the threads are completely disengaged, pull the spout straight out.

**Figure 1
Torque Wrench Attachment**

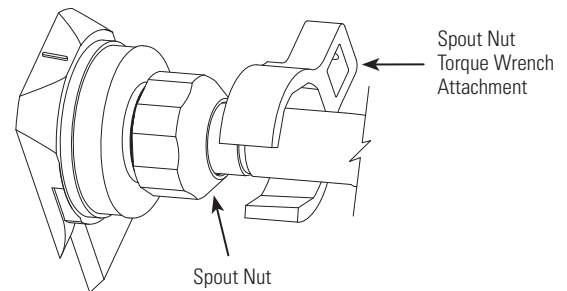

NOZZLE SPOUT ASSEMBLY REPLACEMENT (See Figures 2-3)

1. Fuel chamber should remain in the nozzle casting with the vacuum sensing tube hole oriented at the top.
2. If the fuel chamber is pulled out of the nozzle casting:
 - a. Check O-ring for damage.
 - b. Replace O-ring if damaged (check for cuts, nicks, etc.).
 - c. Lubricate O-ring prior to re-assembly.
3. Insert fuel chamber into nozzle casting:
 - a. Poppet stem with spring goes through poppet hole in the fuel chamber (center hole).
 - b. Push fuel chamber until it is flush with casting.
 - c. Vacuum sensing tube hole in the fuel chamber should be oriented at the top.
4. Lightly lubricate **ALL** O-rings on the spout assembly.
NOTE: Do not block vacuum sensing-tube hole with lubricant.
5. Align vacuum sensing tube with mating hole in the fuel chamber. (See Figure 2)
6. Align the anti-rotation bump on the spout with the casting notch. Be careful not to damage the spout O-ring. (See Figure 2)

**Figure 2
Spout Assembly**

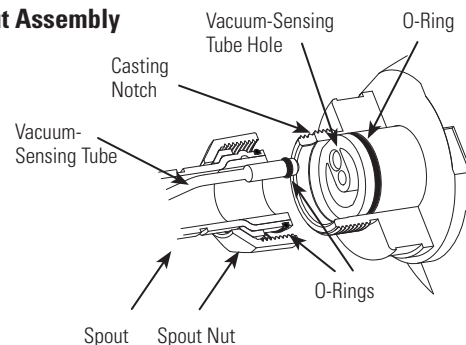

VST Installation Procedure for ENVIRO-LOC™ ECO Diesel NPNF Nozzle Repair Kit (No Pressure No Flow)

Part Number Series:
VST-NSA-700 (Spout Assembly)



Vapor Systems Technologies, Inc.
650 Pleasant Valley Drive
Springboro, Ohio 45066 (USA)
Toll Free: 1-888-878-4673
Phone: 937-704-9333
Fax: 937-704-9443
www.vsthose.com

7. Firmly insert spout assembly into the nozzle casting.
8. Apply a dab of Loctite® 271 to the male thread of the nozzle casting. Be careful not to apply the Loctite® so that it would enter into the casting notch. (See Figure 3)
9. Thread spout nut onto the nozzle casting and tighten firmly. Torque to 34 foot-pounds. Use VST-SRT-200 Spout Nut Torque Wrench Attachment in order to apply the appropriate torque. Spout should be tight and not able to rotate. Do not over-tighten the spout nut.

FUNCTIONAL TESTS

1. Follow the VST Installation Procedure for each hanging hardware component.
2. Purge air from the system by pumping one-tenth (1/10) to two-tenths (2/10) of a gallon of fuel into an approved container. Inspect the nozzle connection for liquid leaks and make proper adjustments at the hose connection if necessary.
3. Check the nozzle shut-off action by dispensing fuel into an approved container at least three times to assure the proper automatic operation. The fuel flow-rate must be greater than 3 gpm for the automatic shut-off mechanism to operate.

To test, operate the nozzle and submerge the spout tip in fuel until the fuel level covers the vent hole. The main valve of the nozzle automatically shuts off when liquid covers the vent hole at the end of the spout. The nozzle is not designed to operate on gravity flow. The hold-open latch will disengage automatically when the liquid covers the vent hole in the spout.

4. Measure the resistance between the dispenser outlet casting and the tip of the nozzle spout. Use an electronic multimeter set on the high range of the ohmmeter function. Resistance should not indicate more than 70,000 ohms per foot of hose. Example: The measured resistance for a 12-foot hose must not exceed 840,000 ohms (840 kilohms).

MAINTENANCE

Inspect nozzles regularly for damaged component parts: spout, lever, and lever lock.

Damaged components must be replaced.

Vent hole at the end of the spout should be clear of debris. The nozzle will not operate properly if the vent hole becomes clogged.

Figure 3
Application of Loctite®

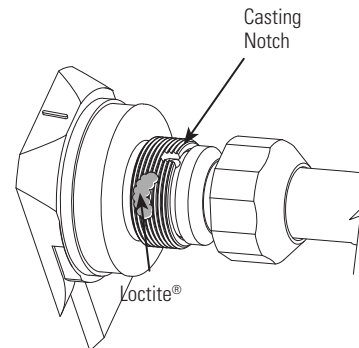

Keep the hose connections tight.

Should there be a drive-off or incidence of customer abuse, follow the initial inspection instructions found in the INSTALLATION section. The nozzle should be replaced when damaged. The nozzle is designed and constructed to give lasting service if properly handled and maintained. If for any reason it should need attention, contact your VST distributor for proper disposition.

NOTE: Due to abuse, misuse, changing fuel formulas, variation in maintenance practices, environmental conditions and/or conditions beyond the manufacturer's control, dispensing equipment may need replacement before five (5) years. Inspections and proper maintenance procedures should be followed by the station manager to determine if replacement is required before five (5) years.

WARNING

Unauthorized rebuilding or modifying of nozzles voids **ALL** approvals and warranties.

VST products must be used in compliance with applicable federal, state and local laws and regulations.

If local regulatory codes prohibit use of the nozzle's hold-open clip, it must be removed prior to nozzle installation. Remove the nozzle to a safe work area.

Place the nozzle on a flat surface.

Locate the alloy rivet securing the hold-open clip and spring in the nozzle's handle. Use a drill with a 3/16" (5mm) drill bit, drill out the rivet securing the hold-open clip, and discard the clip, spring, and all other rivet debris.