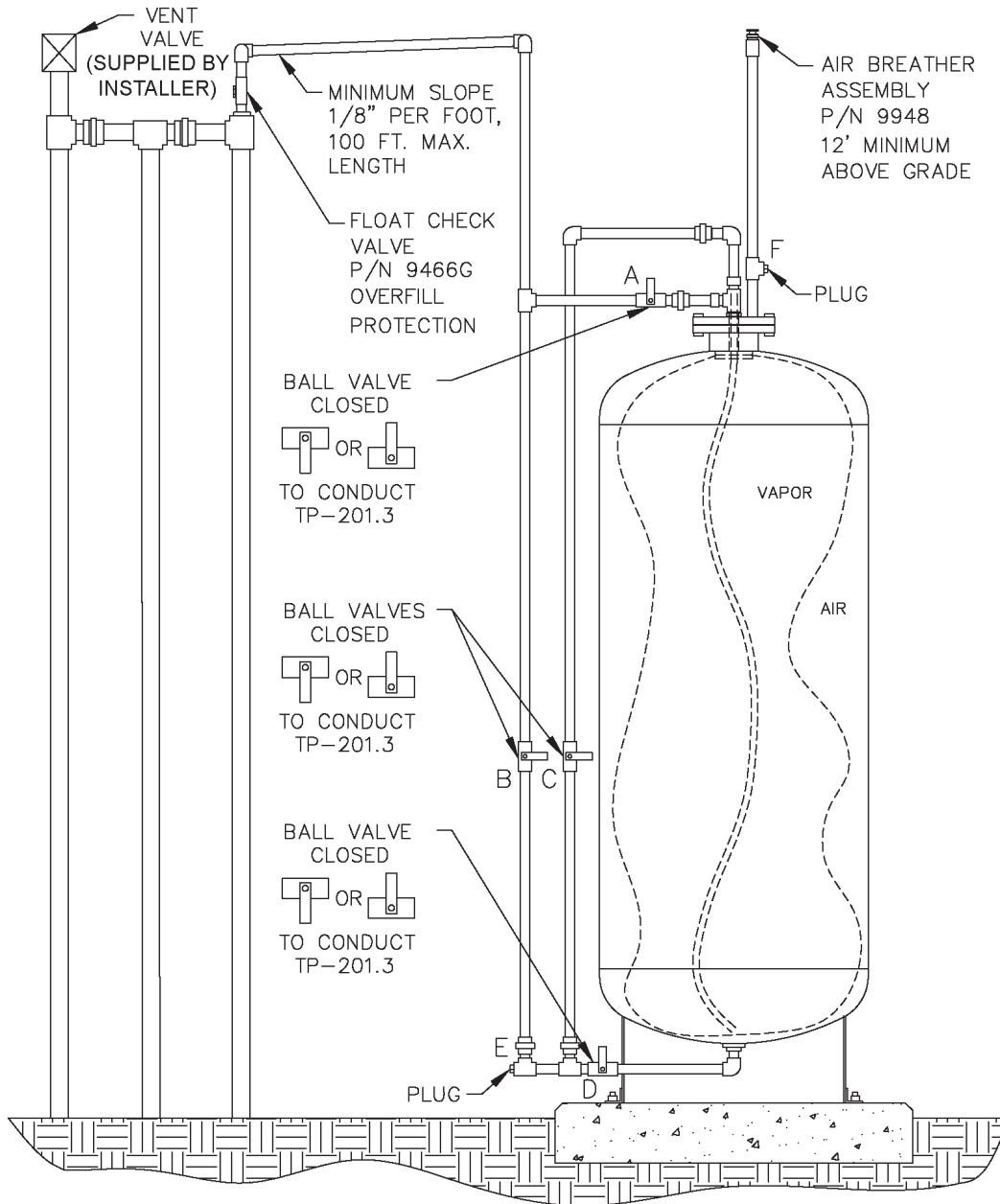
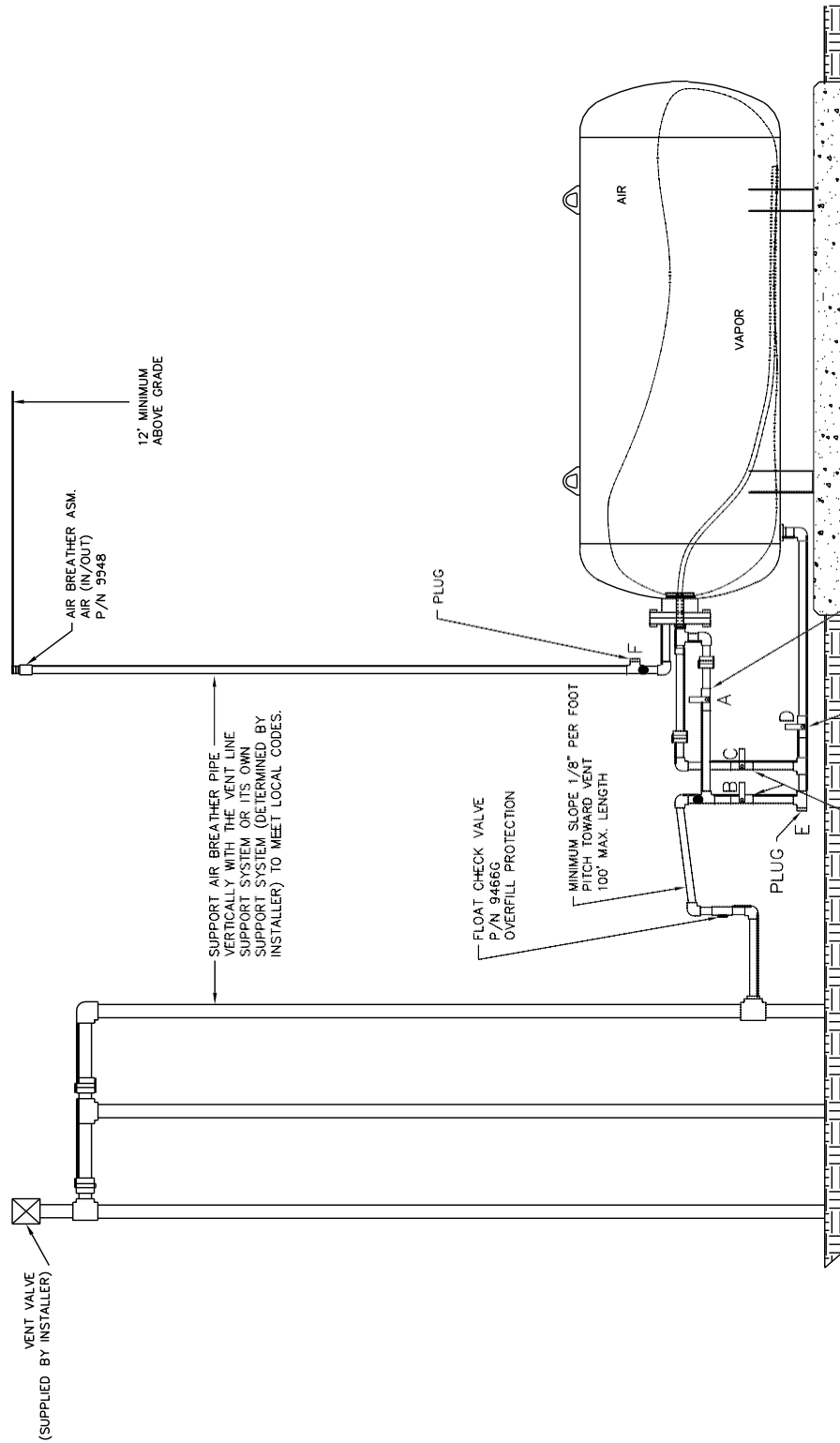



**FIGURE 8-1**  
**Configuration of Healy Clean Air Separator to Conduct TP-201.3**



**FIGURE 8-1H**  
**Configuration of Healy Clean Air Separator to Conduct TP-201.3**





**FIGURE 8-2**  
**Configuration of Permeator Control Panel Hand/Off/Auto**  
**Control Knob in OFF position to Conduct TP-201.3**



**FIGURE 8-3**  
**Configuration of Permeator Control Panel Hand/Off/Auto**  
**Control Knob in AUTO position after Conducting TP-201.3**

