

9.6 Vacuum Pump (Only) Replacement

9.6.1 Preparation for Cleaning the Tubes and Manifold

1. Turn off the GREEN MACHINE breaker in the main electrical distribution panel.
2. Use Lockout/Tagout Procedures prior to starting work.
3. Unlock and close the 3 isolation valves between the GREEN MACHINE and the vent risers.
4. Unscrew the 8 cover screws and remove the cover from the GREEN MACHINE.
5. Remove 6 tubes from the GREEN MACHINE. **See Figures 9-12 & 9-13.**



Figure 9-12: Piping to be removed



Figure 9-13: Piping removed

CAUTION: The tube ends are a Parker 45° flare, use caution not to damage the flared ends on the tubing or the threads on the nuts after removal.

9.6.2 Removing the Vacuum Pump

1. For the Vacuum Pump Assembly and Components, See **Figure 9-14**.

NOTE: The Motor will not be affected during the replacement of the Vacuum Pump.

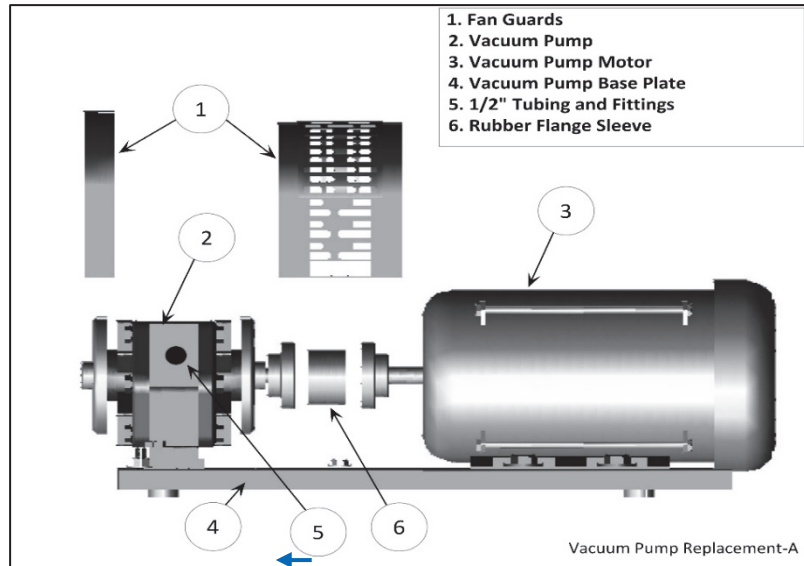

Figure 9-14: Vacuum Pump Assembly and Components

2. Remove the brass pipe fittings from both sides of the Vacuum Pump and keep for reuse.



Figure 9-15: Two Tubes Removed from Vacuum Pump

CAUTION: The fittings are a Parker 45° flare, use caution not to damage the 45° flare fittings or the threads after removal.

3. Remove the side fan guard.

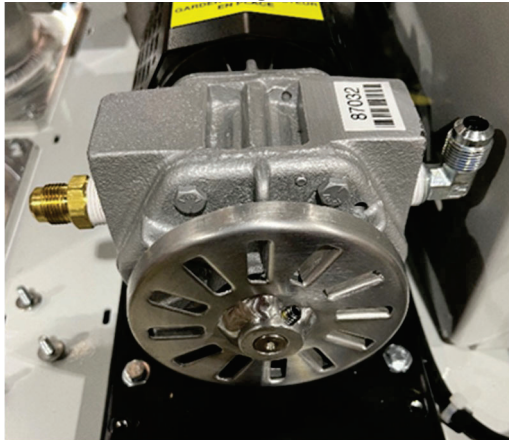

Figure 9-16: Side Fan Guard Removed

4. Remove the 4 mounting bolts from the Vacuum Pump base and keep for re-use.



Figure 9-17: Vacuum Pump Mounting Bolts

CAUTION: There may be metal shims under the Vacuum Pump. They must be marked for location and saved for re-use.

5. Remove the Vacuum Pump.
6. Remove the rubber flange sleeve and discard.

The rubber flange sleeve between the Vacuum Pump and the motor must be replaced with each new pump.

9.6.3 Replacing the Vacuum Pump

1. The new pump will come with a drive coupling and rubber flange sleeve.
See Figure 9-14.
2. Install the flange coupling on to the pump shaft. Then install the rubber flange sleeve into the pump flange coupling so that when the pump is installed, the rubber flange sleeve mates with the motor flange coupling.
3. Place the new Vacuum Pump on the base and align the mounting holes. Remember to re-install the shims under the Vacuum Pump.
4. Reinstall and tighten the 4-Vacuum Pump mounting bolts so the pump shaft aligns with the motor shaft.
5. Slide the drive-coupling flange over the rubber flange sleeve so both halves of the coupling are snug (not tight) against the rubber flange sleeve and tighten the set screws. Double check to make sure both coupling set screws are tight.
6. Wrap the pipe fitting threads with gasoline resistant PTFE tape a maximum of three revolutions and reinstall the pipe fittings.
7. Re-install the fan guards.

9.6.4 Preparation for Cleaning the Tubes and Manifold

1. On the manifold, remove the Solenoids A, B, C, and D from the 4 Control Valves located on the manifold. Do not remove Solenoid E. **See Figure 9-18.**
2. Remove the Retaining Clip from the Solenoid Base and the Nameplate/Retainer and keep for reuse. **See Figure 9-19.**
3. Slide the Solenoid off the Solenoid Base. **See Figure 9-20.**
4. Remove the Spring Washer from the Solenoid Base and keep for reuse.
5. Use a 1" wrench to remove the Solenoid Base from the Valve Body. Keep the Solenoid Base, the Core Assembly and Body Gasket for reuse. **See Figures 9-21.**
6. Place the empty Solenoid Base inside the Solenoid, then attach the Retaining Clip. Do this for all four Solenoids. **See Figures 9-22.**
WARNING: The Solenoid Base MUST BE INSTALLED inside the Solenoid so the magnetic field around the Solenoid will not breakdown when power is applied to the Solenoid.
7. Move the four Solenoids out of the way of the manifold. **See Figure 9-22.**
8. The Manifold is now ready to clean. **See Figure 9-22.**
9. Install the provided Blowout Tube with the clear plastic tubing attached to the discharge side of the Vacuum Pump. Tighten the 45° nut on the fitting hand tight. **See Figure 9-23.**
CAUTION: Do not use any thread sealing compound when assembling the 45° flare nuts on the tubes

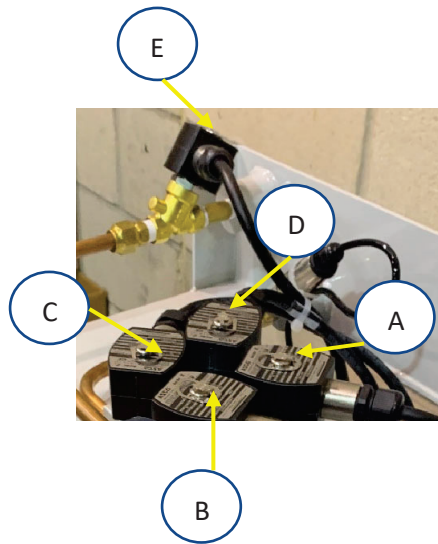

Figure 9-18: Manifold Valves

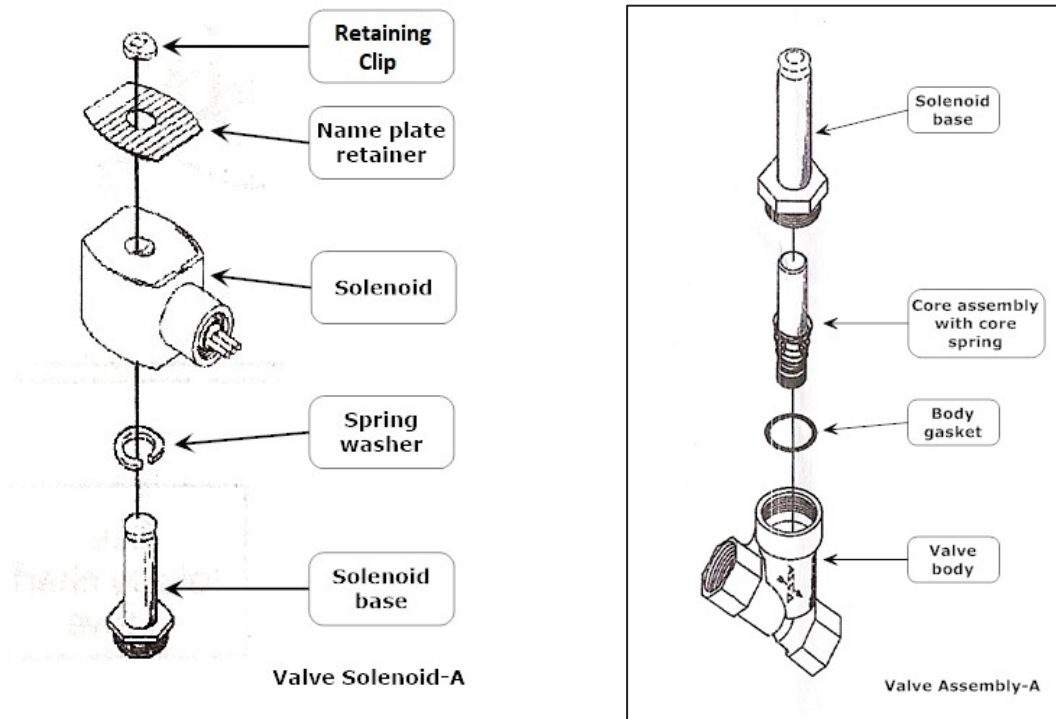

Figure 9-19: Valve Solenoid Assembly

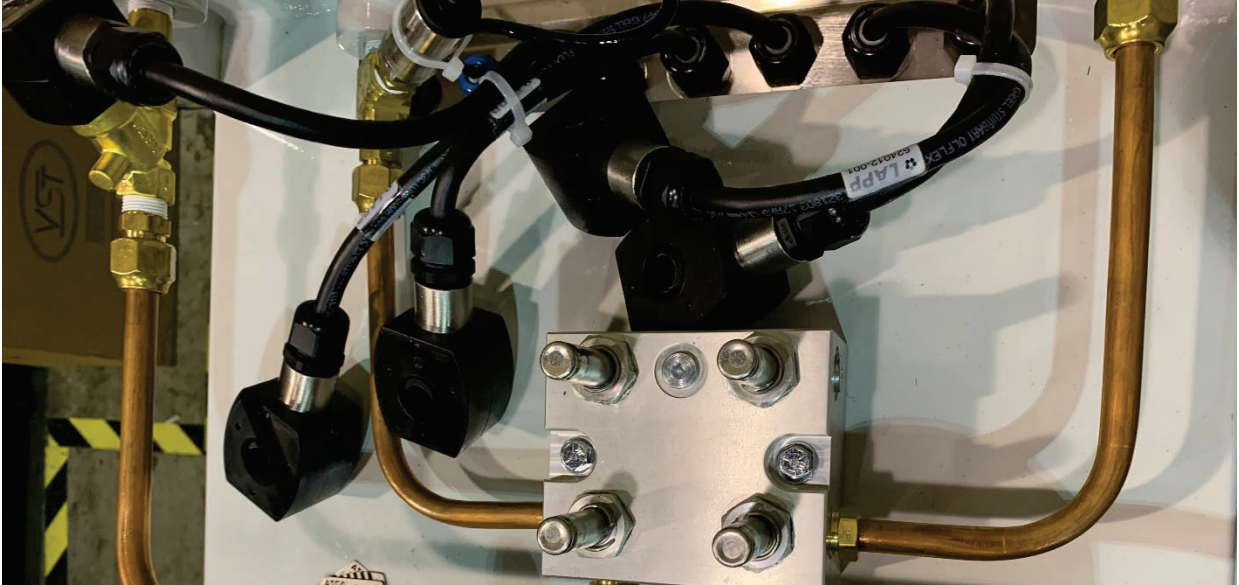

Figure 9-20: Manifold with the Solenoids Removed, showing the Solenoid Bases



Figure 9-21: Solenoids Arranged Out of the Way



Figure 9-22: Solenoids with the Core Assembly Inside

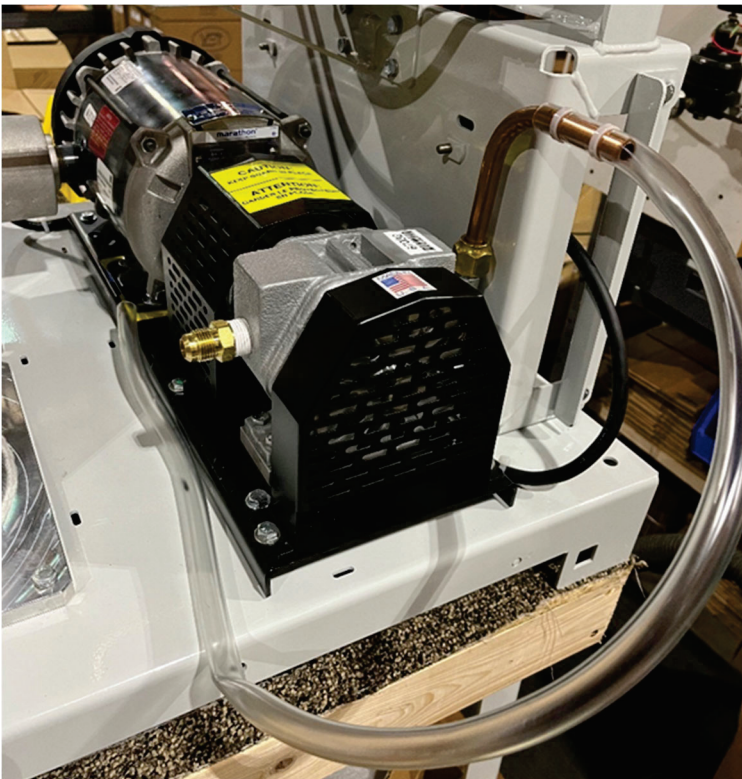

Figure 9-23: Vacuum Pump with the Blowout tube

9.6.5 Cleaning the Tubes and Manifold

1. At the VST Control Panel, remove the Lockout/Tagout lock(s).
2. At the Maintenance Screen, push Run Tests button, then the Functionality Test button to operate the Vacuum Pump. This will allow the Vacuum Pump to blow outside air through the plastic tube. **See Figure 9-24.**

WARNING: Safety Glasses MUST BE USED when blowing out the Tubes and Manifold.

3. Using the plastic tube, blow air through the 6 removed copper tubes to remove any potential debris. **See Figure 9-13.**
4. The Cleaning of the tubes and manifold is complete.
5. At the VST Control Panel Functionality Test Screen, stop the test by pressing the Back button.
6. At the GREEN MACHINE, remove the blowout fitting from the Vacuum Pump.



Figure 9-24: Maintenance Screen

9.6.6 Reassemble the Tubes and Valve Components

1. Remove the Solenoid Bases from the Solenoids. Save the Solenoid Bases and Retaining Clips for reuse.
2. Install the Body Gasket, Core Assembly, and Solenoid Base in the Valve Body. (Typical on all 4 Valve Bodies). **See Figure 9-19.**
CAUTION: The Body Gaskets must be clean and apply fresh Petroleum Jelly lubricant.
3. Install the Solenoids on to the Solenoid Bases, then install the Nameplate/Retainers and Retaining Clips.
4. Reinstall the 6 tubes. **See Figures 9-12.**
CAUTION: Do not use any thread sealing compound when assembling the 45° flare nuts.
CAUTION: When tightening the 45° flare nuts: Clamp the tube flare between nut and nose body of the tube by screwing the nut on finger tight. Tighten with a wrench an additional ¼ turn for a metal-to-metal seal.

9.6.7 Conduct a Functionality Test

Conduct a Functionality Test as shown in Chapter 6 of this document.

9.6.8 Ending Stage

1. Lock open the three ball valves between the GREEN MACHINE and the Vent Risers and replace the caps on the three tees.
2. Put the cover on the GREEN MACHINE and screw on the 8 cover screws.
3. Remove the lock(s) and tags from the lockout & tagout.
4. On the Control Panel, tap the home button. The GREEN MACHINE is now operational.