

# Chapter 7: Maintenance Procedures

## 7 Maintenance Overview

- VST recommends conducting Maintenance on the GREEN MACHINE annually to make sure all the components are in good working order. If the annual maintenance is not conducted, there is a possibility the GREEN MACHINE may not be operating properly.
- The Vacuum Pump, Motor, and Control Valves are the only components with moving parts in the GREEN MACHINE; therefore, it requires very little maintenance.
- All replacement parts must be from VST's recommended replacement parts list located in Chapter 9: Replacement Procedures Section.
- If the GREEN MACHINE is not functioning properly consult Chapter 8: Troubleshooting Section to determine which component may need to be repaired or replaced.

### 7.1 Maintenance Procedures

1. At the VST Control Panel Main Screen, check to make sure there are no alarms. **See Figure 7-1.**  
If there are alarms, repair the item causing the alarm (See Chapter 8: Troubleshooting) before proceeding.
2. VST has recommended spare parts that might be needed when conducting Maintenance. **See Section 7-2.**
3. Conduct a Functionality Test: **See Section 7-3.**  
The Functionality Test will verify the GREEN MACHINE is operating properly.
  - If the Functionality Test Passes, go to Step 4.
  - If the Functionality Test does not Pass (See Chapter 8: Troubleshooting Procedures)
4. The Pressure Sensor Verification Test Procedure: **See Section 7-4.**
  - This procedure will verify that the Pressure Sensor is operating properly and within specifications.
5. Rubber Flange Sleeve Replacement Procedure: **See Section 7-5.**  
To keep the GREEN MACHINE operational, replace the rubber flange sleeve yearly.
6. Cleaning the Control Valves: **See Section 7-6.**  
Cleaning the control valves will reduce valve noise. Check the valve components for wear and damage and keep the valves operational for a longer period of time.
7. Check the Air Outlet for Liquid Condensate: **See Section 7-7.**  
Check annually for liquid condensate in the air outlet pipe.
8. Check the vacuum pump performance: **See Section 7-8.**

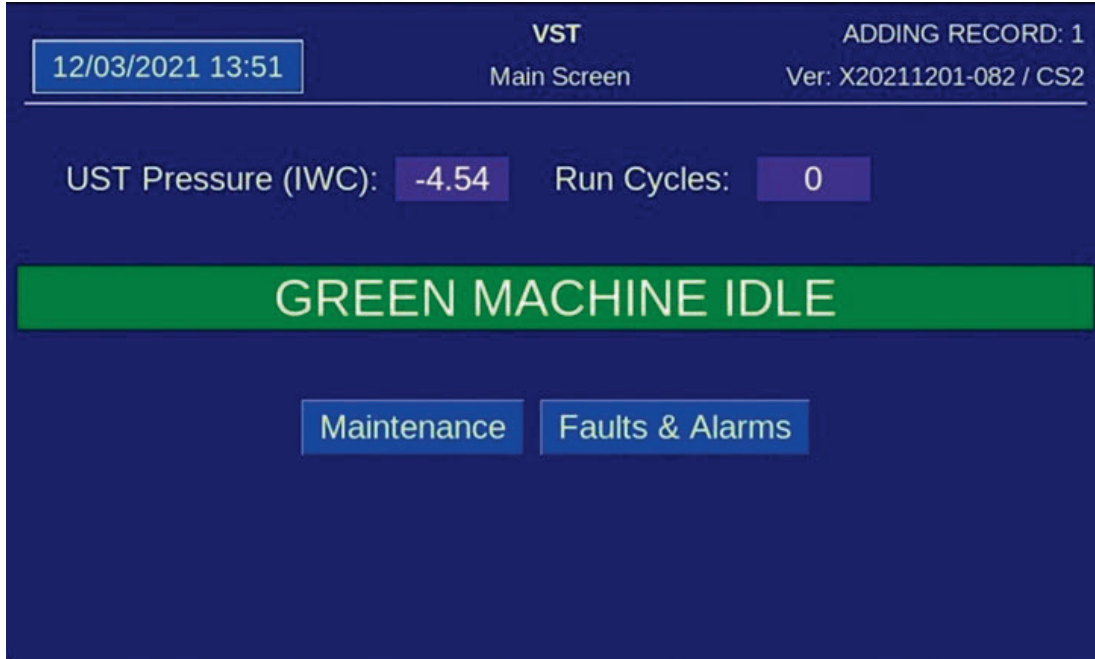

Figure 7-1: VST PLC Main Screen w/no Alarms

## 7.2 Recommended Replacement Parts

VST recommends the ASC bring the parts shown in the table below for replacement parts. The entire list of GREEN MACHINE replacement parts can be found in Chapter 9: Replacement Procedures.

See Figure 7-2.

Ref. #	Description	Part No.	Quantity	Manuf.
1	VACUUM PUMP MOTOR (ONLY), (not shown)	GM-027	1	VST
2	MODEL 2 VACUUM PUMP (ONLY)	GM-042	1	
3	RUBBER FLANGE SLEEVE (not shown)	GM-004	1	
4	CONTROL VALVES – CORE REBUILD KIT	GM-006	5	
5	PRESSURE SENSOR	GM-067	1	

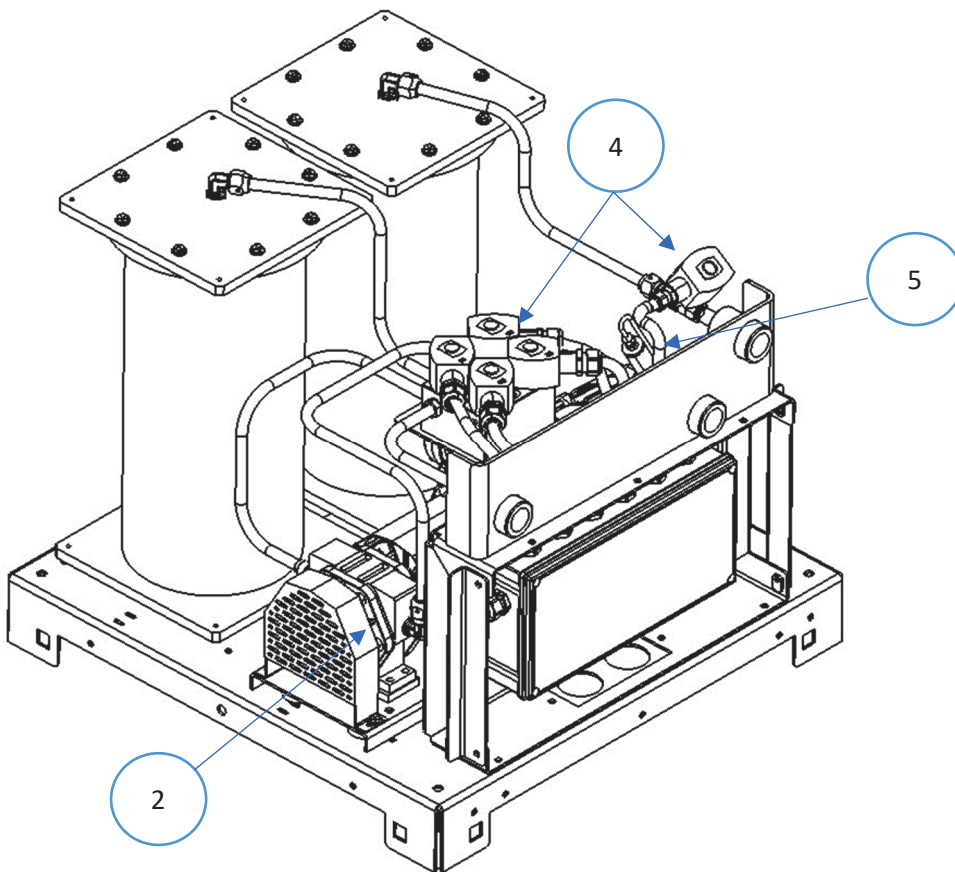

Figure 7-2: Maintenance Replacement Parts

## 7.3 Functionality Test

### 7.3.1 The Purpose of the Functionality Test

The purpose of the Functionality Test is to verify that the Control Panel, Vacuum Pump, and the Control Valves are working properly.

### 7.3.2 Preparation for the Functionality Test

1. At the VST Control Panel, make sure the Maintenance Screen is showing on the PLC. **See Figure 7-3.** (The GREEN MACHINE is now in the Manual OFF mode and will not operate.)

If the PLC is not in the Maintenance Screen: At the Main Screen, push the Maintenance Screen button to access the Password Screen, then enter the password to access the Maintenance Screen: The password is 878.

2. At the GREEN MACHINE, make sure the locks from the three ball valves have been removed, all three valves are closed, and the caps from the three tees have been removed. **See Figure 7-4.**
3. Unscrew the 8 bolts and remove the cover from the GREEN MACHINE.



Figure 7-3: Maintenance Screen

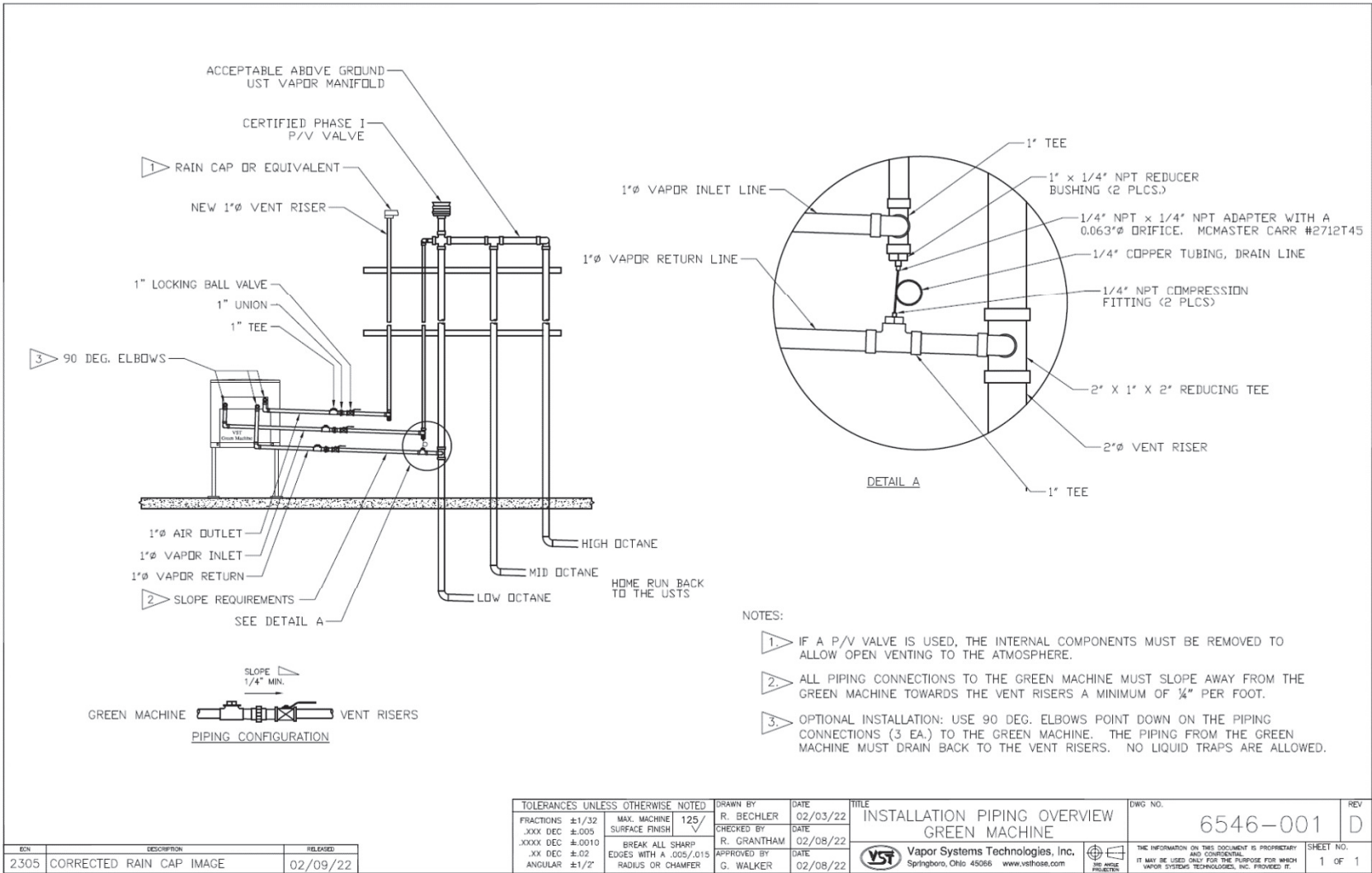

Figure 7-4: GREEN MACHINE Vapor Piping Layout

### 7.3.3 Functionality Test Procedures

1. Press the “Run Tests” button on the Maintenance Screen. **See Figure 7-3.**
2. Select the Functionality Test from the menu. **See Figure 7-5.**
3. To start the Functionality Test, push the Start Button. **See Figure 7-6.**
4. The GREEN MACHINE will run for 60-seconds then purge for 60-seconds (this is one cycle).
5. The GREEN MACHINE will continue to cycle 5 times or until the “stop” is pushed to end the test.
  - There are 5 cycles to provide enough time to conduct the test.
  - The back button or home button can also be pressed to end the test.
6. When the test has ended, the PLC will display GREEN MACHINE OFF.
7. During the 60-second Run Cycle: **See Figure 7-7.**
  - Place your hand over the tee opening at the Vapor Inlet and feel for suction.
  - Next, place your hand over the tee opening at the Vapor Return and feel for zero airflow.
  - Next, place your hand over the tee opening at the Air Outlet and feel for air blowing.
8. During the Run Cycle:
  - 1) Suction at the Vapor inlet: NORMAL
  - 2) Air blowing out the Air Outlet: NORMAL
  - 3) No air blowing/suction at the Vapor Return: NORMAL
  - 4) If these conditions are not found at the respective openings, check the following items:
    - Make sure the Vacuum Pump is not in alarm. If so, see Chapter 8: Troubleshooting.
    - Check the Control Valves to make sure they are all operational. See Chapter 8: Troubleshooting.
    - Make sure there is no debris in the valve seat. Clean the valves as shown in Section 7.6: Cleaning the Control Valves.
    - Make sure the flare nuts are tight. Check each 45° flare nut to make sure they are snug but not over tightened.
9. During the 60-second Purge Cycle: **See Figure 7-7.**
  - After the Purge Cycle has begun, place your hand over the tee opening at the Vapor Return and feel for air blowing. The blowing air will reduce to zero flow soon after the Purge Cycle begins.
  - Next, place your hand over the tee opening at the Vapor Inlet and feel for zero airflow.
  - Next, place your hand over the tee opening at the Air Outlet and feel for zero airflow.

## Functionality Test, continued...

10. During the Purge Cycle:
  - 1) No air blowing/suction at the Vapor Inlet: NORMAL
  - 2) No air blowing/suction at the Air Outlet: NORMAL
  - 3) Momentary blowing at the Vapor Return: NORMAL
  - 4) If these conditions are not found at the respective openings, check the following items:
    - Make sure the Vacuum Pump is not in alarm. If so, see Chapter 8: Troubleshooting.
    - Check the Control Valves to make sure they are all operational. See Chapter 8: Troubleshooting.
    - Make sure there is no debris in the valve seat. Clean the valves as shown in Section 7.6: Cleaning the Control Valves.
    - Make sure the flare nuts are tight. Check each 45° flare nut to make sure they are snug but not over tightened.
11. After the Functionality Test has ended:
  - Lock open the three ball valves between the GREEN MACHINE and the Vent Risers, and replace the caps on the three tees.
  - At the PLC, push the home button to return to the Main Screen.

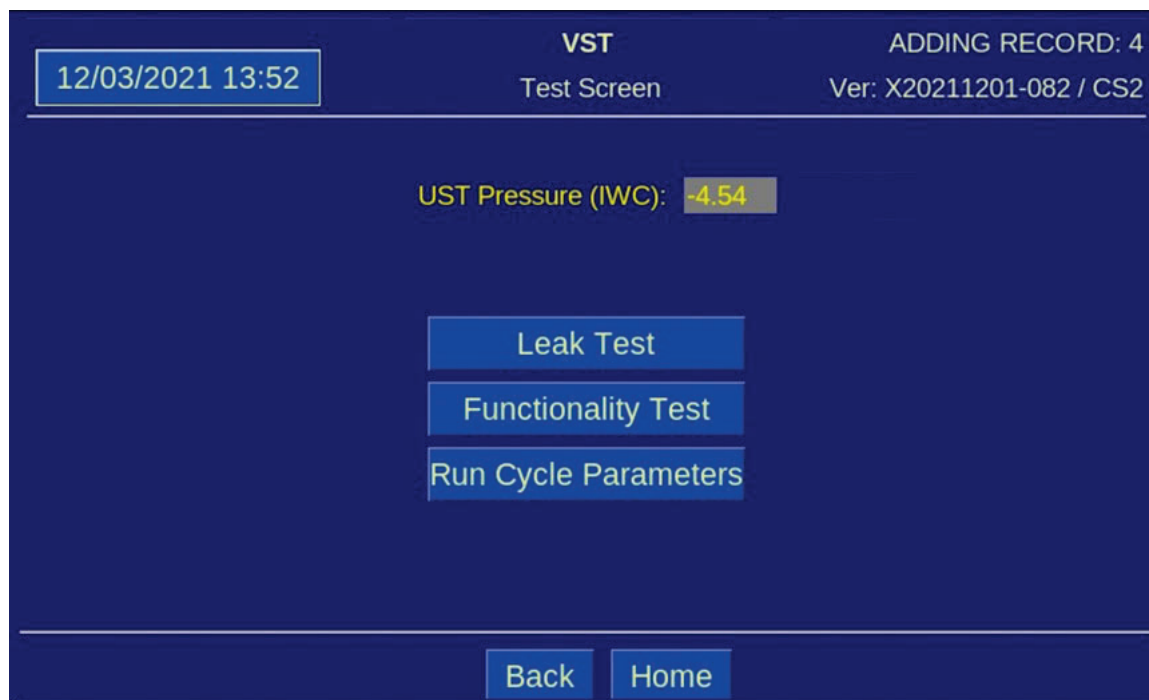

Figure 7-5: Test Screen

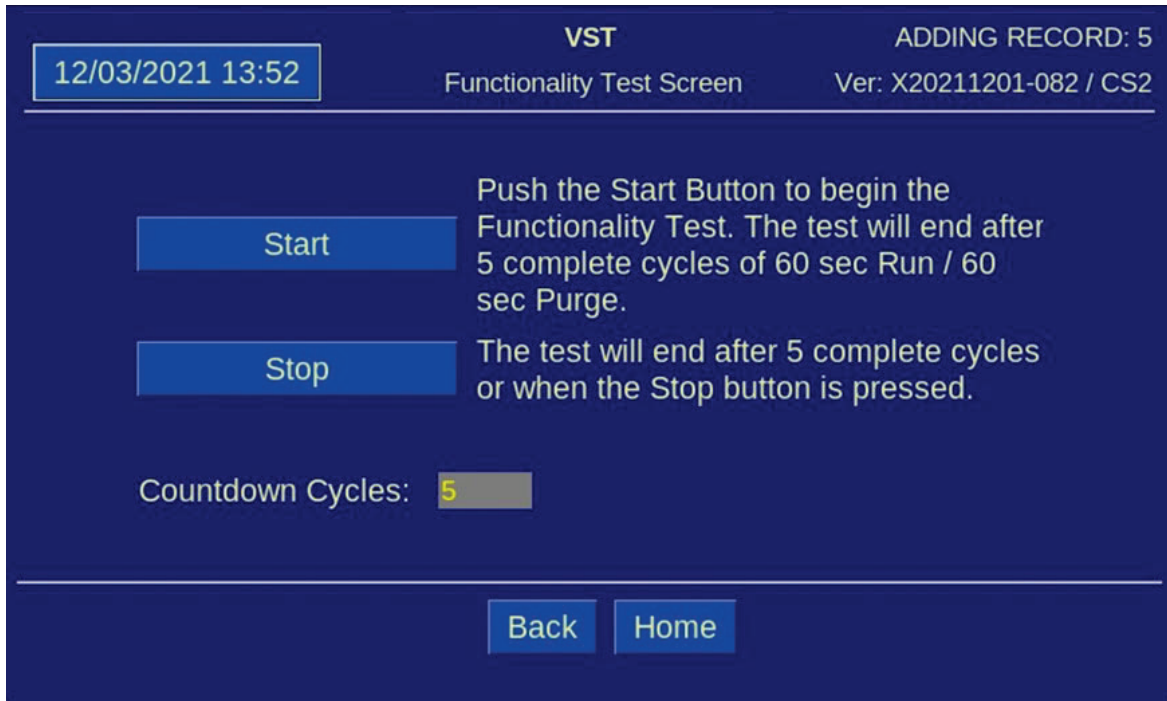

Figure 7-6: Functionality Test Screen

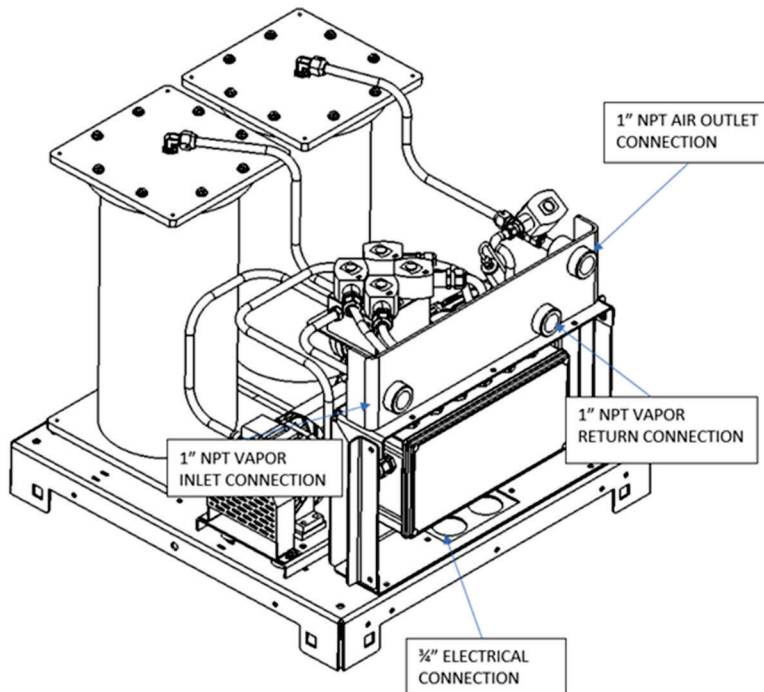

Figure 7-7: GREEN MACHINE Operation Diagram



## 7.4 Pressure Sensor Verification Test

This procedure was written to verify the Pressure Sensor is operating properly and within specifications: The Pressure Sensor reading on the VST Control Panel PLC Main Screen is checked against atmospheric pressure at the Pressure Sensor.

### 7.4.1 Safety:



Use lockout-tagout procedures prior to starting work.

### 7.4.2 Procedure:

1. Enter the Maintenance screen using the code 878 to disable the GREEN MACHINE.
  - This will allow 24 VDC power to the PLC and the Pressure Sensor but will disconnect 120 VAC power to the GREEN MACHINE. Power to the PLC and Pressure Sensor will remain ON.
2. Follow lockout & tagout procedures prior to starting work.
3. Close the ball valve at vapor return line. Then remove the plug on the tee.
4. Wait at least 2-minutes for the pressure to equalize before reading the pressure on the PLC Main Screen.
5. At the VST Control Panel PLC Main Screen, make sure the Pressure reading is 0.0 +/- 0.10 IWC. **See Figure 7-1.**

The Pressure Sensor Specification at atmospheric Pressure is 0.0 +/- 0.10 IWC.

  - If the pressure reading is within specifications, the Pressure Sensor is reading correctly.
  - If the pressure reading is outside the specification, replace the Pressure Sensor. In the IOMT Manual, See Chapter 9 for replacement procedures.
6. After testing is complete: plug the tee and open the ball valve that was closed.
7. Return to the Home screen at the VST Control Panel. The GREEN MACHINE is now operational and will operate if the UST pressure is greater than or equal to 0.20 IWC.
8. Check the VST Control Panel to make sure the Main Screen is showing and there are no alarms.

## 7.5 Rubber Flange Sleeve Replacement

### Safety



Use lockout / tagout procedures prior to starting work.

VST recommends replacing the Rubber Flange Sleeve every time Maintenance is performed on the GREEN MACHINE even if the Rubber Flange Sleeve does not look damaged or worn.

**NOTE: The Rubber Flange Sleeve replacement is done with the vacuum pump motor assembly still attached to the GREEN MACHINE base.**

### 7.5.1 Removing the Rubber Flange Sleeve

**See Figure 7-8.**

1. Turn off the GREEN MACHINE breaker in the main electrical distribution panel.
2. Follow lockout & tagout procedures prior to starting work.
3. Unscrew the 8 cover screws and remove the cover from the GREEN MACHINE.
4. Remove the two tubes attached to the pump.



Figure 7-8: Two tubes removed from vacuum pump

5. Remove the side fan guard.

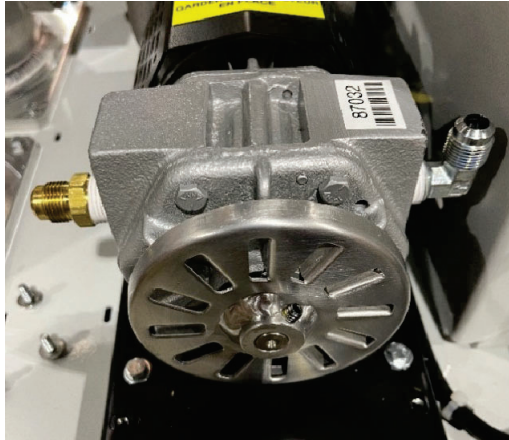

Figure 7-9: Side Fan Guard Removed

6. Remove the 4 vacuum pump mounting bolts. Keep the shims and 4 bolts for reuse.

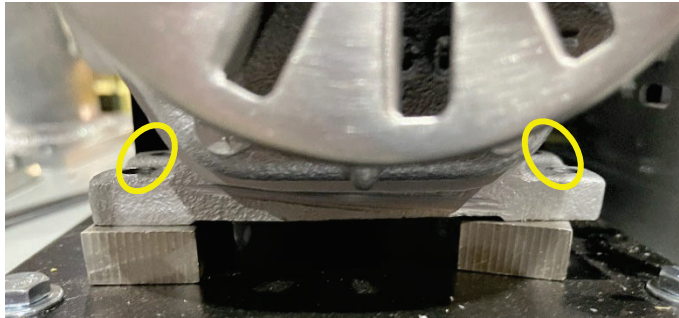

Figure 7-10: Vacuum Pump Mounting Bolts

7. Slide the pump away from the motor so the rubber flange sleeve can be removed.

### 7.5.2 Replacing the Rubber Flange Sleeve

1. Insert a new rubber flange sleeve and slide the pump back to its original position.
  - Make sure the motor-side drive coupling is snug (not tight) against the rubber flange sleeve.
2. Replace any shims that moved while moving the pump.
3. Re-install and tighten the 4 pump mounting bolts to the base plate. Make sure the Motor Shaft and Vacuum Pump shafts are in alignment.
4. Re-install the fan guard over the coupling flanges, and the side fan guard.
5. Put the cover on the GREEN MACHINE and screw on the 8 cover screws.
6. Remove the lock(s) and tags from the lockout & tagout.
7. After the work is completed, return to the Main Screen on the VST Control Panel. The GREEN MACHINE is now operational.

## 7.6 Cleaning the Control Valves

### Safety



Use lockout / tagout procedures prior to starting work.

#### 7.6.1 Removing the Valve Solenoid and Core Assembly

1. Turn off the GREEN MACHINE breaker in the main electrical distribution panel.
2. Follow lockout & tagout procedures prior to starting work.
3. Unscrew the 8 cover screws and remove the cover from the GREEN MACHINE.
4. Unlock and close the three ball valves between the GREEN MACHINE and the vent risers.

See Figure 7-11.

5. Remove the retaining clip from the solenoid that is not working.
6. Remove the nameplate by pushing the solenoid down towards the valve body, then lift and slide the nameplate off.
7. Slide the solenoid off the solenoid base. **DO NOT** lose the spring washer located below the solenoid on the solenoid base.
8. Using a 1" wrench, remove the solenoid base from the valve body, the core assembly with core spring, and the body gasket.
9. Inspect and clean the following parts with a rag and carburetor cleaner or an equivalent cleaning solution: **Be sure to use eyes and hands protection.**
10. Check to make sure the copper ring in the bottom of the solenoid base is not missing or broken into pieces. **See Figure 7-12.**
11. Clean the core assembly, including the metal plunger, the spring, and the rubber seal.
12. Check the rubber seal on the bottom of the core assembly for distortion. Distortion would indicate an indentation into the rubber from the valve seat.
13. Check to see if the spring is cracked or broken.
14. Inspect the body gasket in the valve base for damage and wear.
15. If there is any damage, broken parts, or excessive wear on any part of a control valves assembly, VST recommends that all five control valves be replaced.

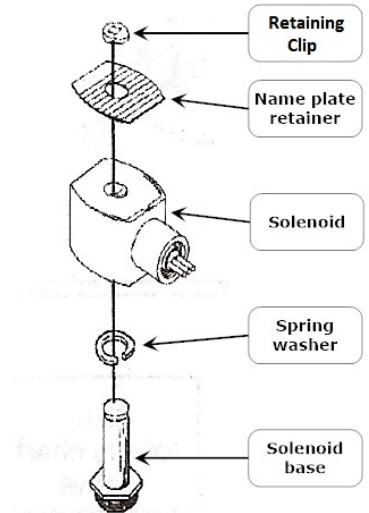

Valve Solenoid-A

Figure 7-11: Valve Solenoid Assembly

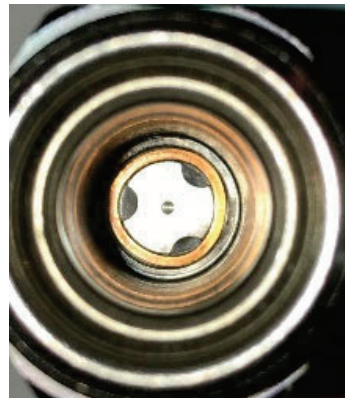

Figure 7-12: Solenoid Base Interior

## 7.6.2 Replacing the Valve Solenoid and Core Assembly

### See Figure 7-13.

1. Install the clean Core Assembly which includes:
  - Solenoid base
  - Core assembly with core spring
  - Body gasket
2. Screw the solenoid base and tighten with a 1" wrench until tight. Make sure to install the body gasket with the solenoid base.
3. Place the spring washer on the solenoid base, then slide the solenoid on to the solenoid base.
4. Slide and lock the nameplate on the solenoid.
5. Snap the retaining clip on the solenoid base.
6. Open the three ball valves between the GREEN MACHINE and the vent risers and lock in the OPEN position.

**CAUTION: THREE BALL VALVES BETWEEN THE GREEN MACHINE AND THE VENT RISERS MUST BE OPEN BEFORE APPLYING POWER TO THE VST CONTROL PANEL TO AVOID DAMAGE TO THE GREEN MACHINE INTERNAL EQUIPMENT.**

7. Put the cover on the GREEN MACHINE and screw on the 8 cover screws.
8. Remove the lock(s) and tags from the lockout & tagout.
9. After the work is completed, return to the main screen on the VST Control Panel. The GREEN MACHINE is now operational.

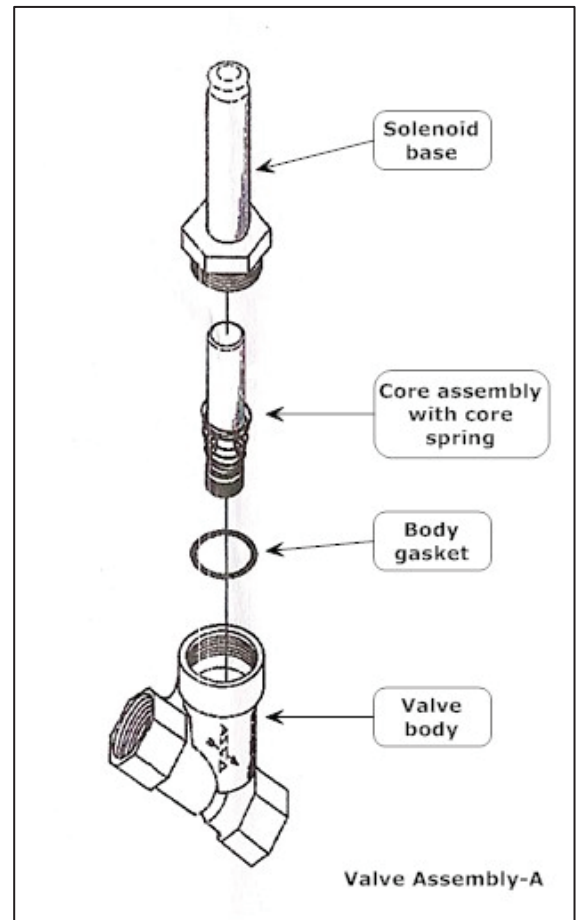

Figure 7-13: Valve Core Assembly

## 7.7 Check the Air Outlet for Liquid Condensation

### 7.7.1 Safety



Use lockout / tagout procedures prior to starting work.

### 7.7.2 Removing the Drain Plug

**See Figure 7-14.**

1. Turn off the GREEN MACHINE breaker in the main electrical distribution panel.
2. Follow lockout & tagout procedures prior to starting work.
3. Place a container below the drain tee at the bottom of the Air Outlet vent riser.
4. Slowly remove the drain plug from the bottom of the Air Outlet vent riser to see if any liquid drains from the line.
5. Keep the drain plug for re-use.

### 7.7.3 Replacing the Drain Plug

**See Figure 7-14.**

1. After all the liquid has drained (if any), put non-hardening pipe-joint compound on the plug threads.
2. Re-install the plug into the drain tee and tighten.
3. Remove the lock(s) and tags from the lockout & tagout.
4. After the work is completed, return to the main screen on the VST Control Panel. The GREEN MACHINE is now operational.

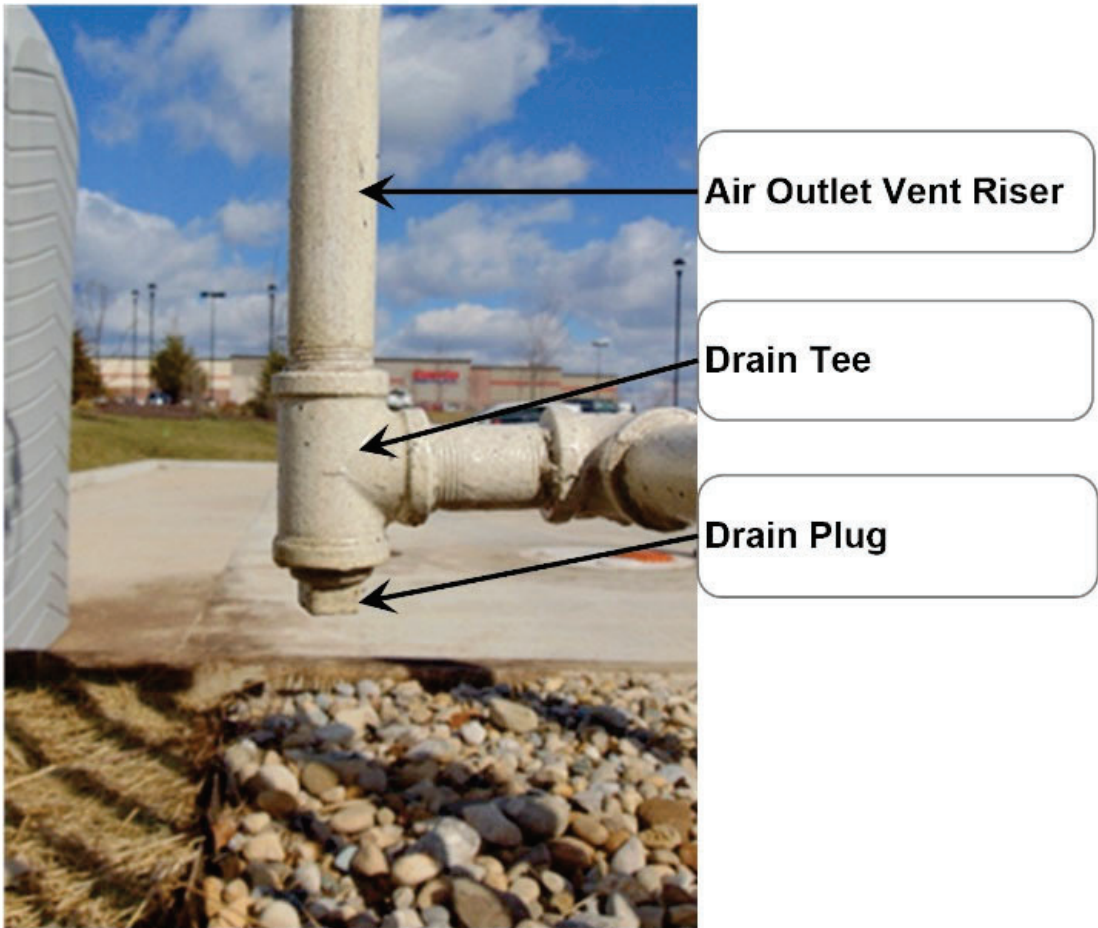

**Air Outlet Drain Tee and Plug, 3-16-2017**

**Figure 7-14: Air Outlet, Drain Tee, and Plug**

## 7.8 Vacuum Pump Performance Test

### 7.8.1 Testing the Vacuum Level of the GREEN MACHINE Vacuum Pump

1. At the VST Control Panel, press the Maintenance button to navigate to the Maintenance Screen. The password is 878. The GREEN MACHINE is now OFF and will not operate.
2. Close the lockable ball valve on the vapor inlet pipe between the GREEN MACHINE and the vent risers.
3. Remove the plug from the tee on the vapor inlet pipe between the GREEN MACHINE and the vent risers.
4. Install a 1" NPT Male x ¼" NPT Female adapter and vacuum gauge on the tee. Use PTFE tape on the gauge and adapter threads. There should be no way for air to enter the vapor inlet port of the GREEN MACHINE.
  - a. VST recommends the Grainger item # 4FLT5 (30-0 in Hg) for a vacuum gauge, or an equivalent.
5. On the Maintenance Screen, press the Manual ON button. This will run the GREEN MACHINE in manual mode until the Manual OFF button is pushed or the cycle completes.
6. At the GREEN MACHINE, during the first 2.5 minutes from pushing the Manual ON button, record the maximum vacuum level achieved by the GREEN MACHINE on the vacuum gauge. The minimum acceptable vacuum level for a given altitude is on **Table 3**. Find the altitude of the site being tested and compare the measured vacuum level with the minimum acceptable vacuum level on the table.
  - a. If the tested vacuum level does not exceed the minimum, the vacuum pump must be replaced.
  - b. If the tested vacuum level exceeds the minimum, the step is complete.
7. At the VST Control Panel, press the Manual OFF button to turn OFF the GREEN MACHINE.
8. Remove the vacuum gauge and 1" x ¼" adapter from the vapor inlet pipe.



Altitude Above Sea Level (feet)	Altitude Above Sea Level (meters)	Minimum Vacuum Level (inHg)
0	0	23.9
1000	305	23.1
2000	610	22.2
3000	914	21.4
4000	1219	20.6
5000	1524	19.9
6000	1829	19.2
7000	2134	18.5
8000	2438	17.8
9000	2743	17.1
10000	3048	16.5

**Table 3: Minimum Vacuum Level by Altitude**

## 7.9 Testing the Flowrate of the GREEN MACHINE Vacuum Pump

1. At the same tee on the vapor inlet pipe, install a 1" NPT Male x ½" NPT Female adapter flowmeter to measure the flow of air into the vapor inlet tee. Two ½" x ½" tubing adapters and ½" dia. tubing are needed. Use PTFE tape on the flowmeter and adapter threads.
  - a. VST Recommends a flow meter with a max of 10 scfm, ½" tubing connections, and 0.25 scfm graduation scale.
2. Once again, press the Manual ON button to begin a cycle.
3. At the GREEN MACHINE, record the maximum flow through the flowmeter. The flow should be at least 4 CFM.
  - a. If the flow is less than 4 CFM, the vacuum pump must be replaced.
  - b. If the flow is greater than 4 CFM, the step is complete.
4. At the VST Control Panel, press the Manual OFF button to turn OFF the GREEN MACHINE.
5. At the GREEN MACHINE, remove the flowmeter and adapter, and reinstall the plug in the vapor inlet pipe between the GREEN MACHINE and the vent risers. Use PTFE tape on the plug threads.
6. Return the GREEN MACHINE to the Main Screen by pressing the ESC button.
7. Open the lockable ball valve on the vapor inlet pipe between the GREEN MACHINE and the vent risers.

---

*This page left intentionally blank*

---