

Chapter 3: Electrical Installation

3 Electrical Safety



- The GREEN MACHINE uses lethal voltages and operates in areas where gasoline vapor may be present.
- Serious injury or death from electrical shock, fire, or explosion may result if the power is ON during installation, testing, or maintenance.
- Be sure to use Lock-Out/Tag-Out procedures when working on or installing the GREEN MACHINE or while working on electrical components.
- When performing maintenance, always power OFF electrical components connected to the GREEN MACHINE. **The GREEN MACHINE can start automatically.**
- Do not use tools that can generate sparks if there is risk of flammable or explosive vapors being present.
- Read and understand all materials related to installing, testing, and operating the GREEN MACHINE prior to installation.

3.1 Electrical Requirements

VST Control Panel Power Requirements						
VST CONTROL PANEL – POWER SOURCES						
Equipment	Phase	Voltage	Amperage	Frequency	Fuse/Breaker Size	Location
ESO Relay power	1-Phase	120VAC	20	60-Hz	20-amp relay	Emergency Shut-Off
Vacuum Pump Motor	1-Phase	120VAC	8 to 10	60-Hz	15-amp breaker	VST Control Panel
Control Valves	1-Phase	120VAC	1.0	60-Hz	5-amp fuse	
24VDC Power supply	1-Phase	120VAC	1.0	60-Hz	2-amp fuse	
Pressure Sensor		24VDC			Protected by 24VDC power supply	
GREEN MACHINE PLC		24VDC			Protected by 24VDC power supply	

Table 1: VST Control Panel Power Requirements

3.2 Electrical Installation

- The VST Control Panel and the GREEN MACHINE Internal Junction Box arrive from the factory pre-wired and completely tested.
- The Electrical Contractor is responsible for supplying all additional wires, conduits, fittings, seal-offs, outlets, and the Safety Disconnect Switch required to install the GREEN MACHINE and meet regulation requirements and standards.
- All wiring must be gasoline and oil resistant.
- A LOCKABLE SAFETY DISCONNECT-SWITCH MUST BE INSTALLED BY THE GREEN MACHINE:
 - Must be wired per included drawings.
 - Should be installed within eye-sight of the GREEN MACHINE for safety reasons.
 - Must not be installed within 3 feet of the GREEN MACHINE.
 - Consult the NEC for restrictions, location, and type of disconnect.
- The GREEN MACHINE is installed in a Class I, Division 2 hazardous location and therefore requires electrical seal-offs when connecting to ordinary, non-hazardous electrical locations. Consult the NEC and NFPA for installation instructions.
- All wiring (120 VAC and 24 VDC) to be TFFN or THHN with 600V insulation.
- The contractor is responsible for sizing the wire, cable, and conduit according to the NEC.
- All power wires connected to the GREEN MACHINE will be disconnected when:
 - The station Emergency Shut-Off is activated.
 - The Safety Disconnect Switch at the GREEN MACHINE is turned off.
 - Power is turned OFF to the VST Control Panel at the electrical distribution panel.
- CAUTION: SAFETY PRECAUTION
 - **BE SURE THE GREEN MACHINE BREAKER INSIDE THE ELECTRICAL PANEL IS LOCKED OUT/TAGGED OUT PRIOR TO THE INSTALLATION.**

3.3 Electrical Installation Code Requirements

- According to NFPA 30:
 - “Electrical wiring and electrical utilization equipment shall be a type specified by and be installed in accordance with NFPA 70. Electrical wiring and electrical utilization equipment shall be approved for the locations in which they are installed.”
- All electrical wiring and electrical utilization equipment must be installed to meet federal, state, and local codes.
- Flexible electrical conduit connections to the GREEN MACHINE may be required by local jurisdictions to meet code requirements.
- Following such procedures may be required by local, state, and national authorities.
 - You must install the GREEN MACHINE in accordance with the National Electric Code (NEC), NFPA 70, and with the Automotive and Marine Service Station Code (NFPA 30A).
 - According to NFPA 30A:
 - “Electrically energized vapor-recovery equipment shall be directly connected to and controlled by the Emergency Shut Off (ESO) in Section 5202.4.7.”

3.4 Electrical Components

Existing Components	VST Supplied Components	Contractor Supplied Components
120V Main Electrical Panel	Pre-wired VST Control Panel	120V Outlet (For maintenance and testing)
Fuel Management System (TLS-350/450) or other	Pre-wired GREEN MACHINE Internal Junction Box	Lockable Safety Disconnect-Switch
Overfill Alarm Output Relay (4-Relay Module)		All conduit, wire, cable, fittings, and seal-offs, and any other electrical material to complete the electrical installation
Emergency Shut-Off (ESO)		Emergency Shut-Off (ESO) Relay if needed (20A, SPDT)

Table 2: Table of Electrical Components

3.5 Electrical Wiring Installation

SAFETY PRECAUTION: PRIOR TO STARTING ANY ELECTRICAL WORK, BE SURE TO USE LOCK OUT / TAG OUT PROCEDURES.

Wires Required to install the GREEN MACHINE:

9 WIRES AND 1 CABLE FROM THE VST CONTROL PANEL TO THE GREEN MACHINE INTERNAL JUNCTION BOX

1. 1 Vacuum Pump 120 VAC Hot
2. 1 Common Neutral
3. 1 Common Ground
4. 1 Control Valve V1 120 VAC Hot
5. 1 Control Valve V2 120 VAC Hot
6. 1 Control Valve V5 120 VAC Hot
7. 1 Safety Switch 120 VAC Hot
8. 1 Safety Switch Leg 120 VAC Hot
9. 1 Safety Switch Ground
10. 1 Cable, 3 conductors, 18 AWG, twisted pair, shielded ground

IN ADDITION, THERE ARE 3 WIRES FOR THE 120 VAC OUTLET FROM THE ELECTRICAL DISTRIBUTION PANEL

1. 1 Outlet 120 VAC Hot
2. 1 Outlet Neutral
3. 1 Outlet Ground

3.5.1 Installing the VST Control Panel:

- The contractor must drill holes in the VST Control Panel for all wiring connections.
- Install the VST Control Panel only inside the GDF. The location may vary within the GDF given the allowable space.
- When possible, place the VST Control Panel as close to the Fuel Management System as possible.
- After the Control Panel is installed and power applied to the panel, **Figure 3-1** shows the Main Screen with the GM DISABLED – ENTER CODE label, which will be discussed later in this Chapter.

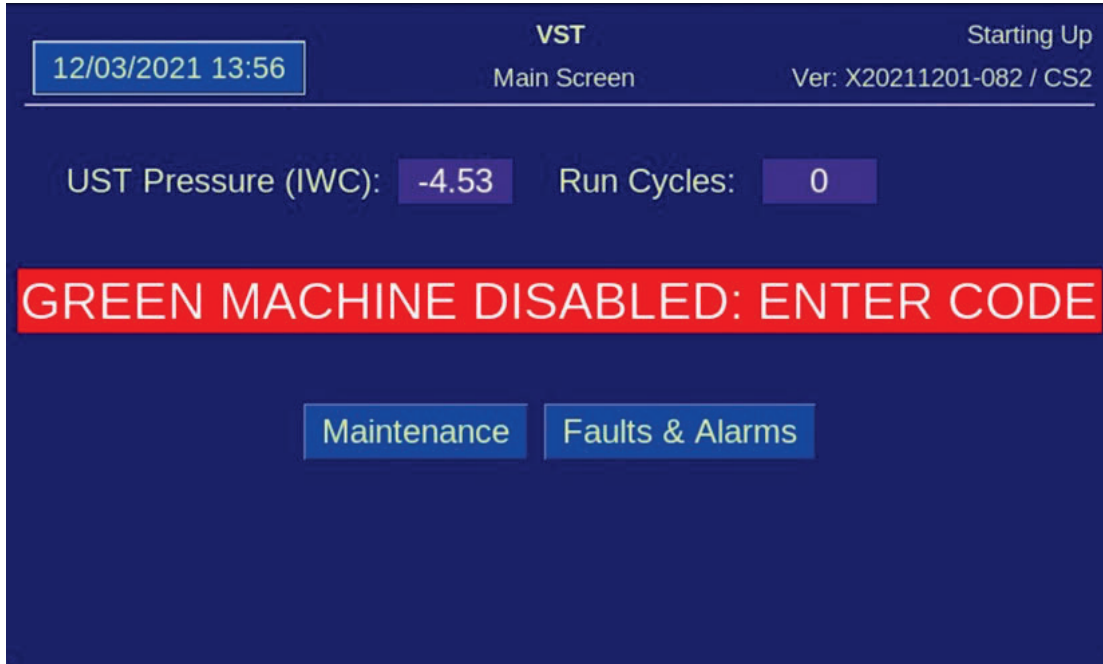

Figure 3-1: Main Screen with GREEN MACHINE DISABLED: ENTER CODE

3.5.2 Power The VST Control Panel from The Station Emergency Shut-Off (ESO) Relay.

Figures 3-3, 3-4: Electrical Overview Drawings for Reference

Supply Power to the GREEN MACHINE from the ESO Relay:

1. Make sure the ESO Relay is 20A or higher.
2. Install the 120 VAC power, the neutral, and the ground wires from the ESO Relay to the VST Control Panel.
 - ESO L1 120 VAC Hot to Wire Number 02011
 - ESO Neutral to Wire Number 02012
 - ESO Ground to Ground

3.5.3 Wiring the Electrical Components at the GREEN MACHINE Location.

Figure 3-5: Shows the Field Wiring from the VST Control Panel to the GREEN MACHINE Internal Junction Box: Vacuum Pump Motor, Pressure Sensor, Safety Disconnect Switch

1. Wiring the Internal Junction Box
 - a. Install 6 wires from the VST Control Panel to the junction box
 - a. Vacuum Pump 120 VAC to wire number 02054
 - b. Vacuum Pump Neutral to wire number 02012
 - c. Control Valve V1 120 VAC to wire number 02071
 - d. Control Valve V2 120 VAC to wire number 02072
 - e. Control Valve V5 120 VAC to wire number 02080
 - f. Ground to Ground
2. Pressure Sensor Cable
 - a. Install 1-Pressure Sensor Cable from the VST Control Panel to the Internal Junction Box
 - b. The cable is supplied by the contractor
 - c. The cable must be 3-conductor, 18 AWG, twisted and shielded
 - 24 VDC (+) to wire number 03030
 - 4-20 mA SIGNAL to wire number 04040
 - Shielded ground (Lead wire is a bare ground)
3. Safety Disconnect Switch
 - a. Install 2 wires from the VST Control Panel to the Safety Disconnect Switch
 - 120 VAC to wire number 02011
 - 120 VAC switch leg to wire number 02020
 - Ground to Ground

3.5.4 Wiring the Overfill Alarm Field Wiring

Figure 3-5: Shows the Overfill Alarm Field Wiring from the VST Control Panel to the Fuel Management System

1. The VST Control Panel supplies 24 VDC to an Overfill Alarm relay.
2. The Overfill Alarm output relay is a “dry” relay (N.C.) that shuts down the GREEN MACHINE when a UST reaches the Overfill Level volume during a fuel drop.
3. Install two shielded wires from the VST Control Panel to the Fuel Management System Overfill Alarm (N.C.) output relay. (Refer to the Fuel Management System Installation Manual for connecting and configuring the correct relay. Programming of the Overfill Relay will be completed by a certified technician.)
 - a. TLS-350 or equivalent Overfill Alarm Relay Circuit.
 - b. Connect to the COMM Bay, 4-Relay Module
 - 24 VDC (+) to wire number 03030
 - 24 VDC (signal) to wire number 05050

OR

 - c. TLS-450 PLUS or equivalent Overfill Alarm Relay Circuit
 - d. Connect to the Module Bay, I/O Module
 - 24 VDC (+) to wire number 03030
 - 24 VDC (signal) to wire number 05050

3.5.5 Wiring the VST Control Panel to the GREEN MACHINE

Figure 3-8: Wires from the VST Control Panel to the GREEN MACHINE Internal Junction Box Wiring Diagram.

1. This drawing is used for wiring from the VST Control Panel to the Internal Junction Box for the Vacuum Pump Motor, the 5-control valves, and the Pressure Sensor. For Reference.

3.5.6 Wiring the Pressure Sensor

Figure 3-9: Wiring Diagram of the Pressure Sensor.

1. This drawing is used for wiring from the Internal Junction Box to the Pressure Sensor located inside the GREEN MACHINE cover.

3.5.7 Applying Power to the VST Control Panel

After all the wiring connections listed below are completed and checked, power can be turned ON at the VST Control Panel. The following items have been installed and wired:

1. VST Control Panel
2. Emergency shut-Off Relay
3. Overfill Alarm Relay
4. GREEN MACHINE Internal Junction Box
5. Pressure Sensor
6. Safety Disconnect Switch
7. Outlet

After power is turned ON to the VST Control Panel (See **Figure 3-1**), the Main Screen will show **GM DISABLED – ENTER CODE**. This means:

1. The VST Control Panel has power through the ESO Relay.
2. The GREEN MACHINE cannot operate because Testing & Start-Up has not been completed.
3. The GREEN MACHINE cannot be started by the Electrical Contractor.
4. See **Figure 3-1**: VST Control Panel PLC Main Screen – GM Disabled – Enter CODE Main Screen

Before turning OFF power the VST Control Panel, check to make sure there are no GREEN MACHINE or PRESSURE Alarms.

On the Main Screen, push the Faults & Alarms button. This will bring up the Alarms Screen.

All the items on the screen should be green, indicating there are no alarms present. See **Figure 3-5**.

GREEN MACHINE ALARMS

- A. Vac Pump Alarm
- B. Panel Power Alarm
- C. Overfill Alarm
- D. Digital Storage Alarm

PRESSURE ALARMS

- E. UST Pressure < -6.00 IWC Alarm
- F. UST Pressure > +2.00 IWC Alarm
- G. UST 0.00 +/- 0.15 IWC Alarm
- H. UST VAR. +/- 0.20 Alarm
- I. PRESSURE SENSOR Alarm
- J. 72 HR SHUTDOWN Alarm if any pressure alarm persists as described in the Vapor Recovery Regulations

If an Alarm is present, call Vapor Systems Technologies at 937-704-9333 for instructions.

CAUTION: TURN OFF POWER TO THE VST CONTROL PANEL AT THIS TIME.

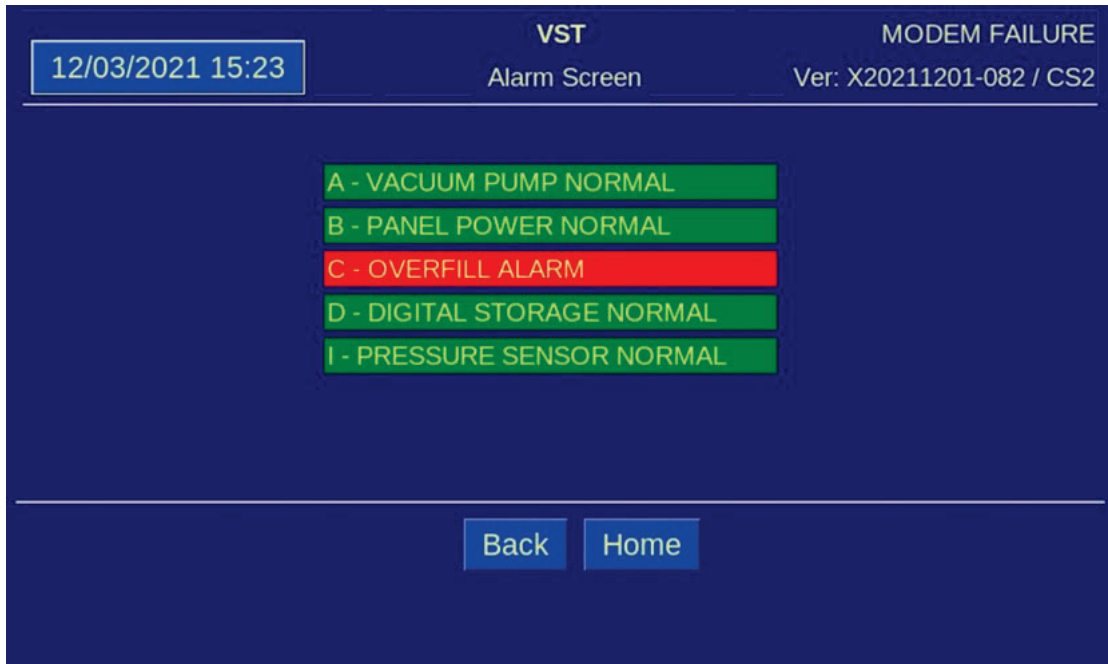

Figure 3-2: VST Control Panel PLC Alarm Screen

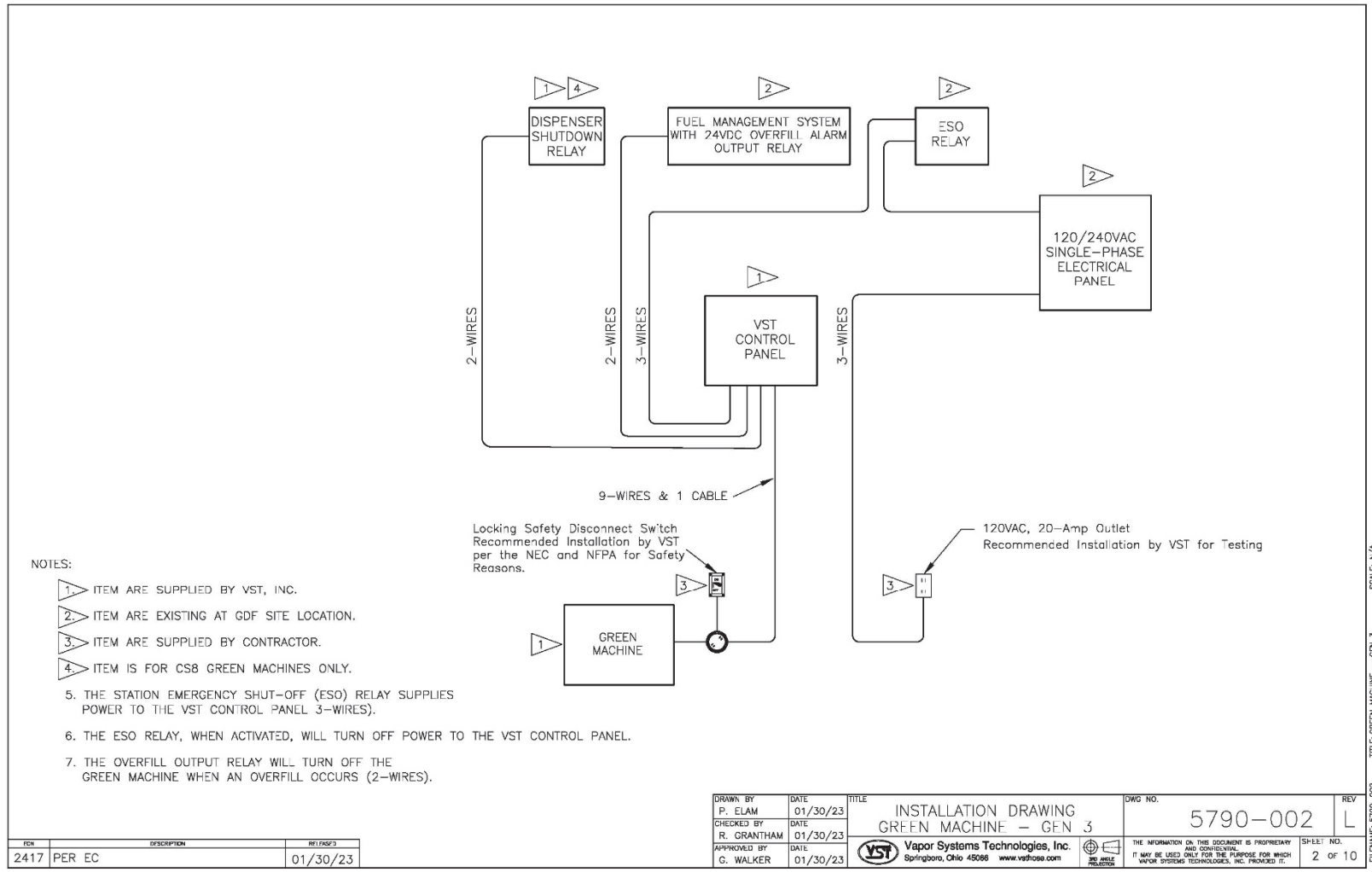

Figure 3-3: The GREEN MACHINE Installation Overview

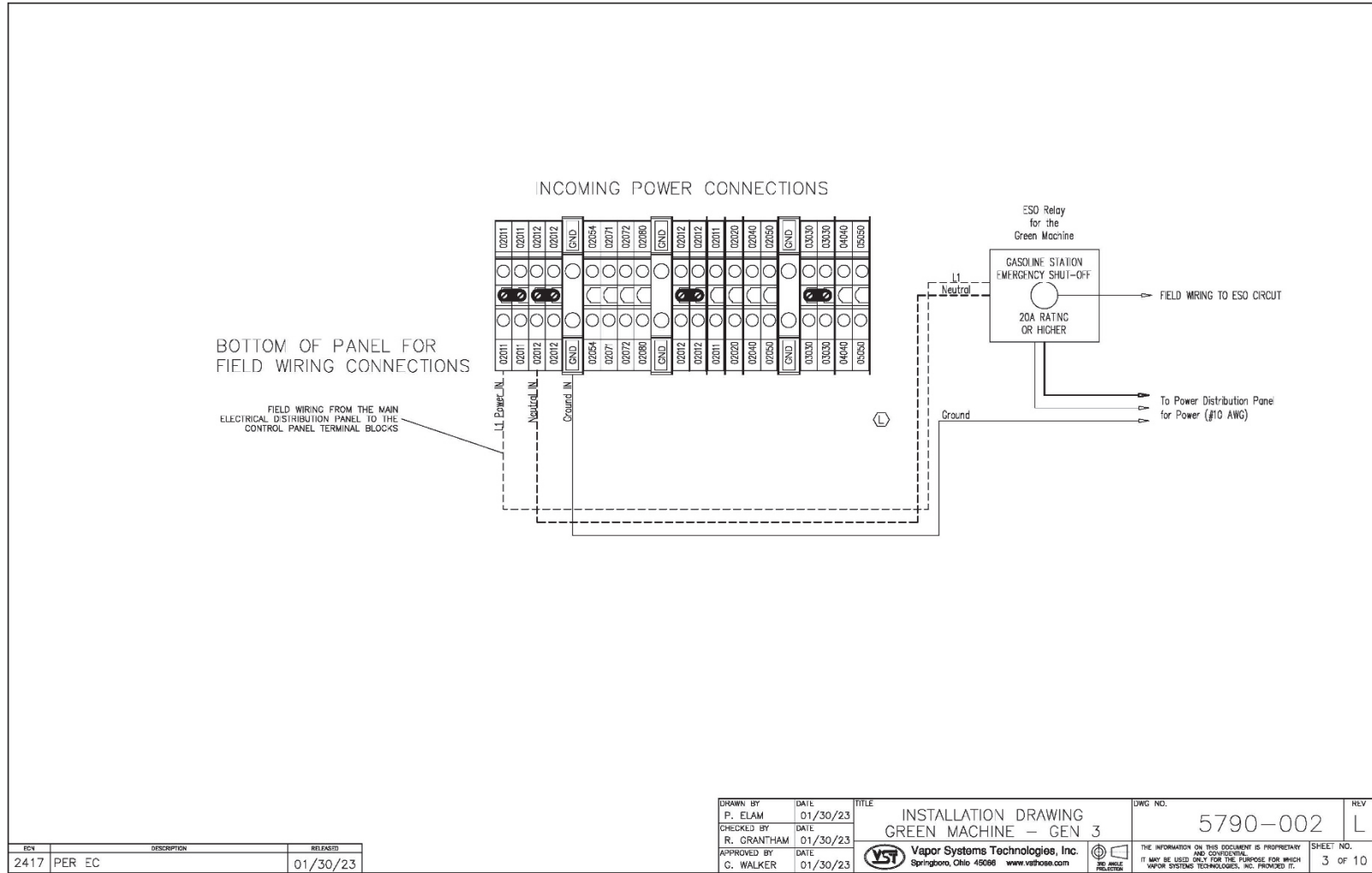

Figure 3-4: The Control Panel Power Connection

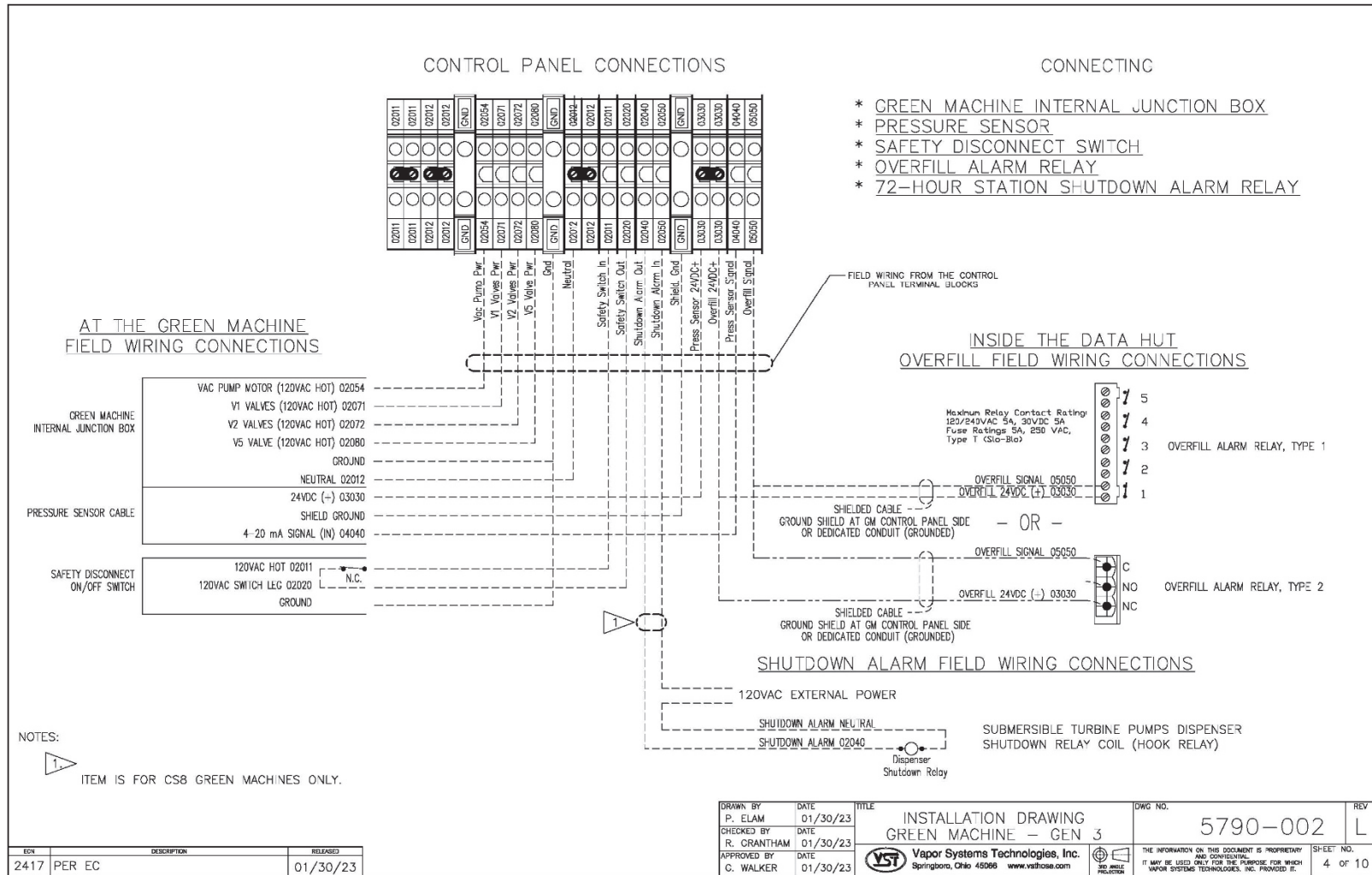

Figure 3-5: The VST Control Panel Field Wiring

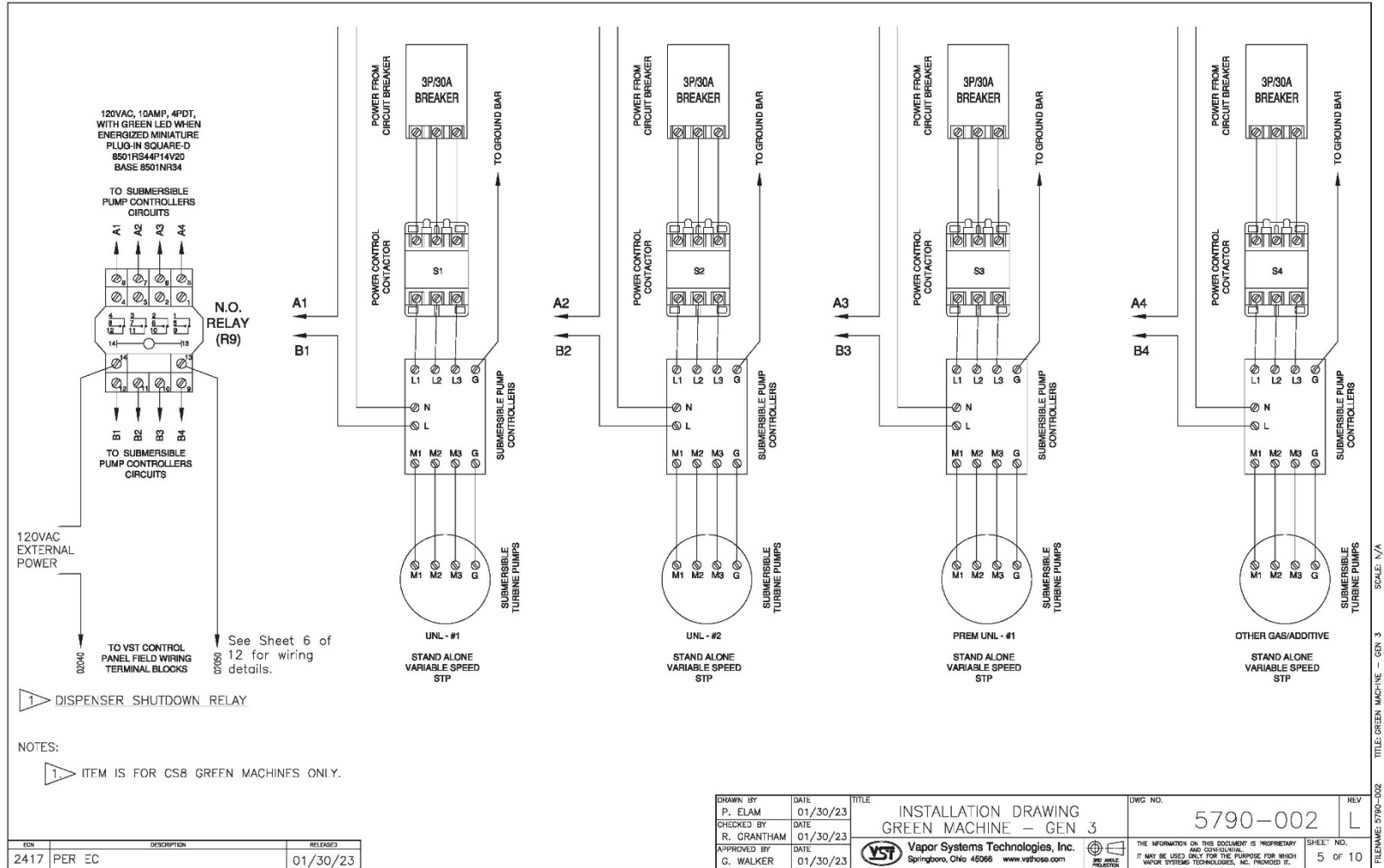

Figure 3-6: GREEN MACHINE Dispenser Shutdown Field Wiring

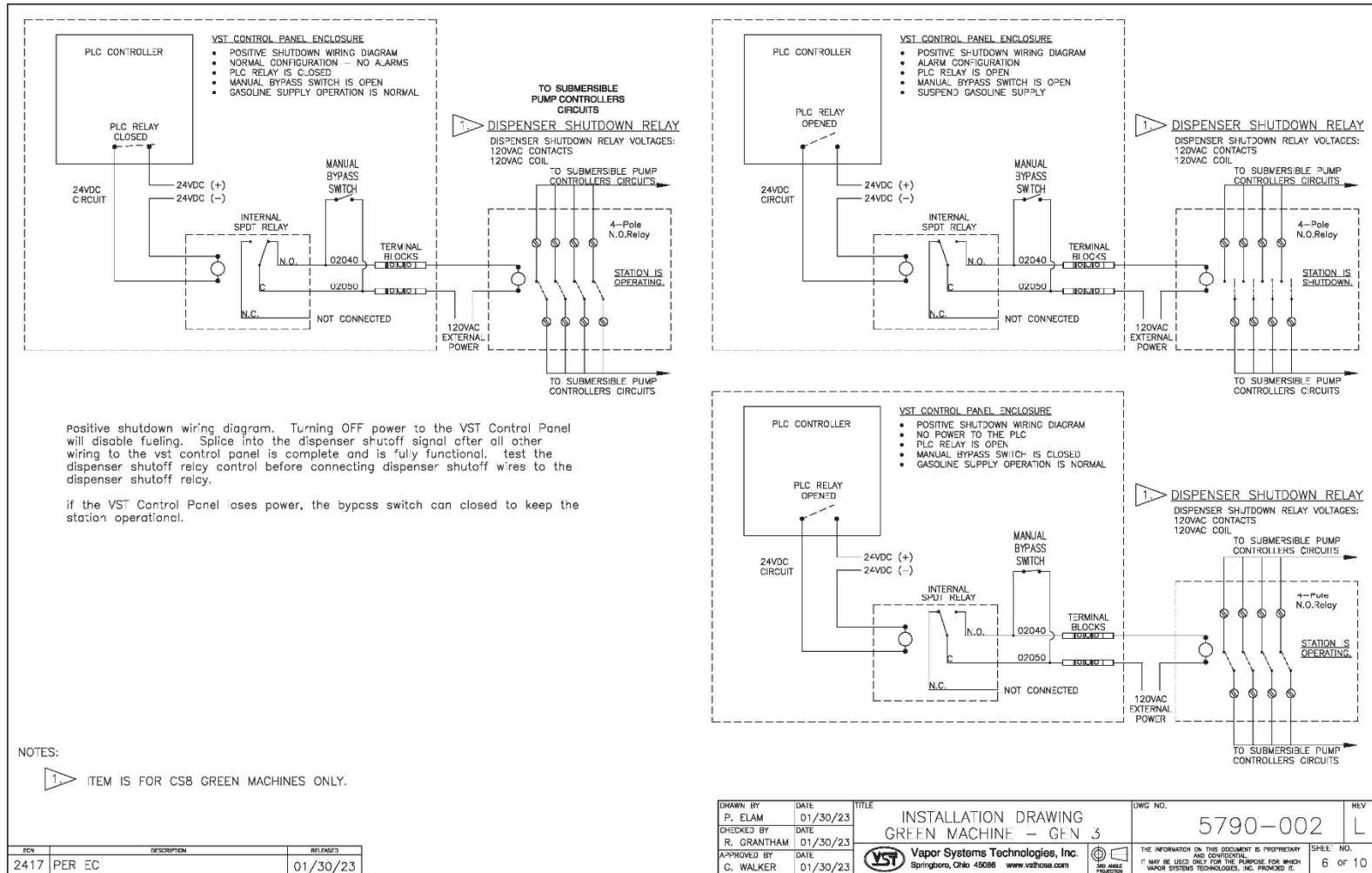

Figure 3-7: GREEN MACHINE Dispenser Shutdown Field Wiring

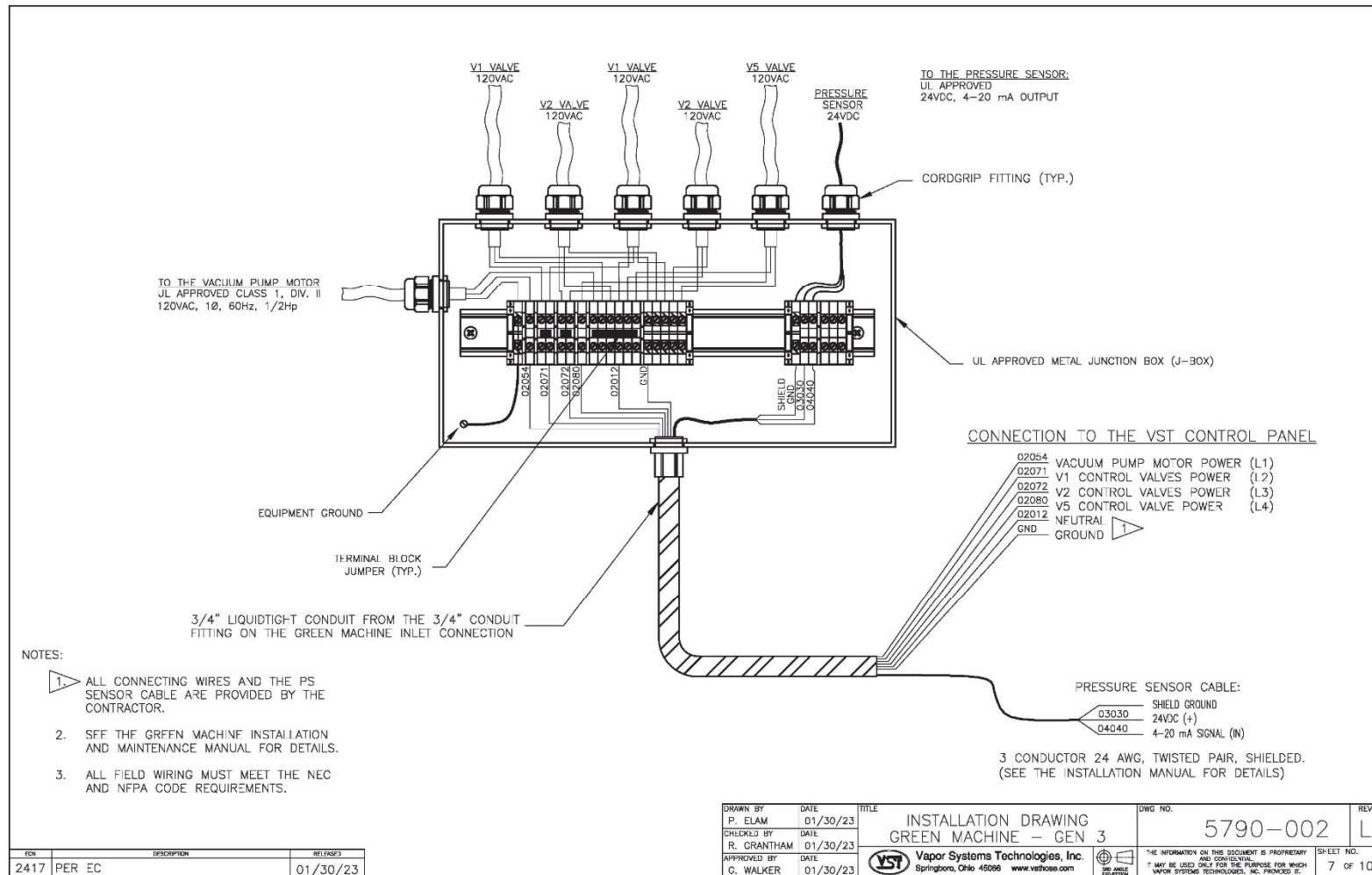

Figure 3-8: GREEN MACHINE Junction Box Field Wiring

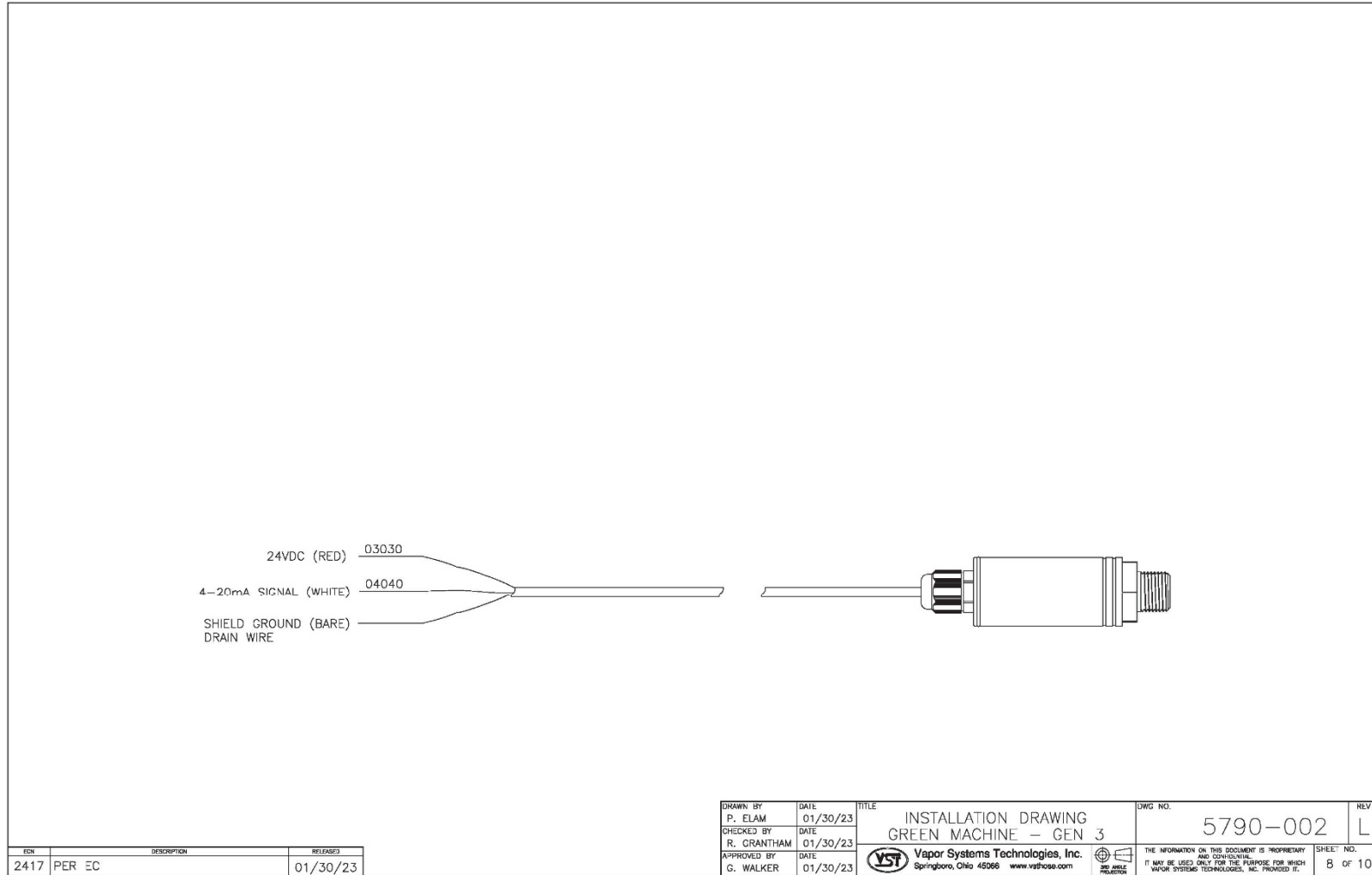

Figure 3-9: GREEN MACHINE Dispenser Shutdown Field Wiring