



GREEN MACHINE™ - US

(Patents Pending)

Model # VST- GM3- CS2A-101

Installation, Operation, Maintenance, & Troubleshooting Manual

Rev. 1.0 – Published February 2023

Manual # 9600-016



Vapor Systems Technologies, Inc.

650 Pleasant Valley Drive
Springboro, Ohio 45066
(937) 704-9333 PH
(937) 704-9443 FX
www.vsthose.com

This page left intentionally blank

Table of Contents

Table of Contents.....	3
Table of Figures.....	8
GREEN MACHINE	11
Notice.....	11
Warranty	11
Safety	11
Table of Terms & Abbreviations	13
Regulations & Jurisdiction	13
GREEN MACHINE Overview	14
GREEN MACHINE Theory of Operation	15
GREEN MACHINE Dimensions & Weight	16
How the GREEN MACHINE is Shipped	16
Chapter 1: General Contractor Installation	18
1 Installation Instructions.....	18
1.1 Installation Safety for all Contractors.....	18
1.2 Preparing the GREEN MACHINE for Installation.....	18
1.3 Installing the Legs on the GREEN MACHINE.....	18
1.4 GREEN MACHINE Dimensions & Weight	19
1.5 Ground Mount Locations.....	19
1.6 Setting the Concrete Pad.....	20
1.7 Installing the GREEN MACHINE on the Concrete Pad.....	21
1.8 Roof-Top Installation	24
1.9 Canopy-Top Installation.....	24
1.10 Vent-Stack Mount Installation	25
Chapter 2: Vapor Piping Installation	28
2 Vapor Piping Installation Overview.....	28
2.1 General Notes.....	28
2.2 Flexible Piping.....	30
2.3 Vapor Inlet and Vapor Return Piping Installation.....	31
2.4 Air Outlet Piping Installation	32
2.5 Vapor Piping Post-Installation	32
2.6 Vapor Piping Bill of Material.....	33

Chapter 3: Electrical Installation	35
3 <i>Electrical Safety</i>	35
3.1 Electrical Requirements.....	35
3.2 Electrical Installation	36
3.3 Electrical Installation Code Requirements.....	36
3.4 Electrical Components.....	37
3.5 Electrical Wiring Installation.....	37
3.5.1 Installing the VST Control Panel:.....	38
3.5.2 Power The VST Control Panel from The Station Emergency Shut-Off (ESO) Relay.....	38
3.5.3 Wiring the Electrical Components at the GREEN MACHINE Location.....	39
3.5.4 Wiring the Overfill Alarm Field Wiring.....	39
3.5.5 Wiring the VST Control Panel to the GREEN MACHINE	40
3.5.6 Wiring the Pressure Sensor.....	40
3.5.7 Applying Power to the VST Control Panel.....	40
Chapter 4: Control Panel	49
4 <i>VST Control Panel Overview</i>	49
4.1 Main Screen Overview.....	50
4.2 Maintenance Screen Overview.....	51
4.3 Alarm Screen Overview	52
4.4 GREEN MACHINE Alarm Screen.....	52
Chapter 5: Data Collection.....	54
5 <i>Data Collection</i>	54
5.1 USB Drive Collection Steps	54
5.2 MicroSD Card Collection Steps	55
Chapter 6: Testing & Start-Up.....	57
6 <i>Post-Installation GREEN MACHINE Testing & Start Up</i>	57
6.1 VST Control Panel Initial Start-Up Power:	57
6.2 Before beginning the Testing and Start-Up procedures.....	57
6.3 Post Installation Start-Up Tests	58
6.4 How to get a Verification Code:.....	58
6.5 Functionality Test	59
6.5.1 The Purpose of the Functionality Test	59
6.5.2 Preparation for the Functionality Test.....	59
6.5.3 Functionality Test Procedures.....	61
6.6 Programming the Fuel Management System Overfill Alarm Relay for the GREEN MACHINE.....	64
6.7 Testing the Overfill Alarm on the GREEN MACHINE VST Control Panel	65
6.8 Changing the Date and Time Procedure.....	65
6.9 Submitting Appendix B to VST for the Verification Code	67
6.9.1 Start Up of the GREEN MACHINE.....	67
6.9.2 Procedures	67
Chapter 7: Maintenance Procedures.....	70
7 <i>Maintenance Overview</i>	70
7.1 Maintenance Procedures	70
7.2 Recommended Replacement Parts	72
7.3 Functionality Test	73
7.3.1 The Purpose of the Functionality Test	73

7.3.2	Preparation for the Functionality Test.....	73
7.3.3	Functionality Test Procedures.....	76
7.4	Pressure Sensor Verification Test.....	79
7.4.1	Safety:.....	79
7.4.2	Procedure:.....	79
7.5	Rubber Flange Sleeve Replacement.....	80
7.5.1	Removing the Rubber Flange Sleeve.....	80
7.5.2	Replacing the Rubber Flange Sleeve.....	81
7.6	Cleaning the Control Valves.....	82
7.6.1	Removing the Valve Solenoid and Core Assembly.....	82
7.6.2	Replacing the Valve Solenoid and Core Assembly.....	83
7.7	Check the Air Outlet for Liquid Condensation.....	84
7.7.1	Safety.....	84
7.7.2	Removing the Drain Plug.....	84
7.7.3	Replacing the Drain Plug.....	84
7.8	Vacuum Pump Performance Test.....	86
7.8.1	Testing the Vacuum Level of the GREEN MACHINE Vacuum Pump.....	86
7.9	Testing the Flowrate of the GREEN MACHINE Vacuum Pump.....	87
Chapter 8: Troubleshooting.....		89
8	<i>Troubleshooting Procedures.....</i>	<i>89</i>
8.1	Troubleshooting Procedures Overview.....	89
8.1.1	Troubleshooting the GREEN MACHINE and the VST Control Panel.....	89
8.2	Alarm Overview.....	90
8.2.1	Alarm List.....	91
8.3	Troubleshooting Procedures.....	92
8.4	Power to the VST Control Panel or PLC Controller is OFF.....	92
8.4.1	Control Panel General Information.....	92
8.4.2	Panel Power Alarm: Troubleshooting Steps.....	93
8.5	Pressure Sensor Alarm.....	95
8.5.1	Pressure Sensor Alarm: Troubleshooting Steps.....	95
8.6	Vacuum Pump Alarm.....	97
8.6.1	Vacuum Pump Alarm: Troubleshooting Steps.....	98
8.7	Overfill Alarm.....	106
8.7.1	Overfill Alarm Troubleshooting Steps.....	107
8.8	Data Storage Alarm.....	109
Chapter 9: Replacement Procedures.....		110
9	<i>Replacement Parts Procedures.....</i>	<i>110</i>
9.1	List of Replacement Parts.....	110
9.1.1	VST Control Panel Replacement Parts.....	111
9.1.2	Replacement Procedures by Part.....	113
9.2	Control Panel Small Components Replacement.....	113
9.2.1	Vacuum Pump Motor Breaker Replacement.....	113
9.2.2	Vacuum Pump Motor Solid-State Relay Replacement.....	115
9.3	Pressure Sensor Replacement.....	117
9.3.1	Removing the Pressure Sensor.....	117
9.3.2	Installing the Pressure Sensor.....	117
9.4	Rubber Flange Sleeve Replacement.....	120
9.4.1	Removing the Rubber Flange Sleeve.....	120
9.4.2	Replacing the Rubber Flange Sleeve.....	121
9.5	Control Valve Replacement.....	122

9.5.1	Removing the Valve Solenoid and Core Assembly.....	122
9.5.2	Replacing the Valve Solenoid and Core Assembly	123
9.6	Vacuum Pump (Only) Replacement.....	124
9.6.1	Preparation for Cleaning the Tubes and Manifold.....	124
9.6.2	Removing the Vacuum Pump.....	125
9.6.3	Replacing the Vacuum Pump	127
9.6.4	Preparation for Cleaning the Tubes and Manifold.....	127
9.6.5	Cleaning the Tubes and Manifold	132
9.6.6	Reassemble the Tubes and Valve Components	133
9.6.7	Conduct a Functionality Test.....	133
9.6.8	Ending Stage.....	133
9.7	Leak Test	134
9.7.1	Purpose of the Leak Test.....	134
9.7.2	Preparation for the Leak Test	134
9.7.3	Leak Test Procedure.....	137
Appendix A - General Contractor Check-Out Form		142
Appendix B - Start-Up Contractor Check-Out Form		146

This page left intentionally blank

Table of Figures

Figure 1-1: Concrete mounting pad dimensions	22
Figure 1-2: GREEN MACHINE Ground Mounting Pad	23
Figure 1-3: Vent Stack Installation	26
Figure 2-1: Vapor Piping Overview.....	29
Figure 2-2: GREEN MACHINE Connections.....	30
Figure 3-1: Main Screen with GREEN MACHINE DISABLED: ENTER CODE.....	38
Figure 3-2: VST Control Panel PLC Alarm Screen.....	41
Figure 3-3: The GREEN MACHINE Installation Overview	42
Figure 3-4: The Control Panel Power Connection	43
Figure 3-5: The VST Control Panel Field Wiring.....	44
Figure 3-6: GREEN MACHINE Dispenser Shutdown Field Wiring.....	45
Figure 3-7: GREEN MACHINE Dispenser Shutdown Field Wiring.....	46
Figure 3-8: GREEN MACHINE Junction Box Field Wiring.....	47
Figure 3-9: GREEN MACHINE Dispenser Shutdown Field Wiring.....	48
Figure 4-1: Main Screen.....	49
Figure 4-2: Maintenance Screen Overview	51
Figure 4-3: Alarm Screen	52
Figure 4-4: Alarm Screen with Active Alarm	53
Figure 5-1: Primary and Secondary Data Storage Units.....	54
Figure 6-1: Main Screen with Disabled Message	57
Figure 6-2: Maintenance Screen	59
Figure 6-3: GREEN MACHINE Vapor Piping Layout.....	60
Figure 6-4: Test Screen	62
Figure 6-5: Functionality Test Screen	63
Figure 6-6: GREEN MACHINE Operation Diagram	63
Figure 6-7: Main Screen.....	65
Figure 6-8: Date and Time Screen	66
Figure 6-9: Startup Screen	68
Figure 6-10: Startup Password Screen.....	68
Figure 7-1: VST PLC Main Screen w/no Alarms	71
Figure 7-2: Maintenance Replacement Parts.....	72
Figure 7-3: Maintenance Screen	73
Figure 7-4: GREEN MACHINE Vapor Piping Layout.....	74
Figure 7-5: Test Screen	77
Figure 7-6: Functionality Test Screen	78
Figure 7-7: GREEN MACHINE Operation Diagram	78
Figure 7-8: Two tubes removed from vacuum pump	80
Figure 7-9: Side Fan Guard Removed	81
Figure 7-10: Vacuum Pump Mounting Bolts	81
Figure 7-11: Valve Solenoid Assembly.....	82
Figure 7-12: Solenoid Base Interior	82
Figure 7-13: Valve Core Assembly	83
Figure 7-14: Air Outlet, Drain Tee, and Plug	85
Figure 8-1: VST GREEN MACHINE Control Panel Main Screen	89
Figure 8-2: VST GREEN MACHINE Control Panel Main Screen with an Alarm Active	90
Figure 8-3: VST Control Panel Alarms and Faults Screen Example	91
Figure 8-4: VST Control Panel 120 VAC Power Circuit Diagram	94
Figure 8-5: Pressure Sensor Wiring Diagram (24VDC Power and 4-20 mA Signal)	96
Figure 8-6: Vacuum Pump Troubleshooting Procedures	97

Figure 8-7: Maintenance Screen100

Figure 8-8: Tests Screen.....100

Figure 8-9: Control Valves102

Figure 8-10: Vacuum Pump Circuit.....104

Figure 8-11: VST Control Panel Electrical Components105

Figure 8-12: GREEN MACHINE PLC Alarm Screen106

Figure 8-13: Fuel Level Tank Alarms108

Figure 9-1: GREEN MACHINE Replacement Parts.....110

Figure 9-2: VST Control Panel, Inside Panel Replacement Parts112

Figure 9-3: Vacuum Pump BRK1.....114

Figure 9-4: Vacuum Pump Solid State Relay116

Figure 9-5: Wiring the Pressure Sensor Inside the Internal Junction Box118

Figure 9-6: Pressure Sensor Installed in GREEN MACHINE119

Figure 9-7: Two tubes removed from vacuum pump120

Figure 9-8: Side Fan Guard Removed121

Figure 9-9: Vacuum Pump Mounting Bolts.....121

Figure 9-10: Valve Solenoid Assembly.....122

Figure 9-11: Valve Assembly123

Figure 9-12: Piping to be removed124

Figure 9-13: Piping removed124

Figure 9-14: Vacuum Pump Assembly and Components125

Figure 9-15: Two Tubes Removed from Vacuum Pump125

Figure 9-16: Side Fan Guard Removed126

Figure 9-17: Vacuum Pump Mounting Bolts126

Figure 9-18: Manifold Valves128

Figure 9-19: Valve Solenoid Assembly.....128

Figure 9-20: Manifold with the Solenoids Removed, showing the Solenoid Bases.....129

Figure 9-21: Solenoids Arranged Out of the Way130

Figure 9-22: Solenoids with the Core Assembly Inside.....131

Figure 9-23: Vacuum Pump with the Blowout tube131

Figure 9-24: Maintenance Screen132

Figure 9-25: Vapor Piping Overview135

Figure 9-26: Maintenance Screen.....136

Figure 9-27: Leak Test Screen136

Figure 9-28: Leak Check Fixture139

Figure 9-29: GREEN MACHINE leak test.....140

This page left intentionally blank

GREEN MACHINE

Notice









Vapor Systems Technologies, Inc. shall not be liable for errors contained herein or for incidental or consequential damages in connection with the furnishing, performance, or use of this publication.





No part of this publication may be translated to another language without the prior written consent of Vapor Systems Technologies, Inc.

Warranty

See the VST website for full warranty statement: <http://www.vsthose.com/warranty>

Safety

	<p>ELECTRICITY A potential shock hazard exists. High voltage is supplied to and exists in this device.</p>		<p>TURN POWER OFF Turn power OFF to the device and its accessories when installing and servicing the unit. Live power creates a potential spark hazard.</p>
	<p>EXPLOSIVE Gasoline and its vapors are extremely explosive if ignited.</p>		<p>NO POWER TOOLS Sparks from electric power tools can ignite gasoline and its vapors.</p>
	<p>FLAMMABLE Gasoline and its vapors are extremely flammable.</p>		<p>NO PEOPLE IN THE AREA Unauthorized people in the work area during installation and service of the device create a potential for personal injury.</p>
	<p>NO SMOKING Gasoline and its vapors can be ignited by sparks and embers of burning cigarettes.</p>		<p>READ ALL RELATED MATERIALS Read, understand, and follow all instructions, warnings, and requirements before you begin work.</p>

	<p>NO OPEN FLAMES Open flames from sources like lighters and matches can ignite gasoline and its vapors.</p>		<p>USE SAFETY BARRICADES Unauthorized people in the work area during installation and service of the device create a potential for personal injury. Therefore, always isolate your work area by using safety cones, barricades, etc.</p>
	<p>PINCH RISK Stay clear. Keeps hands and tools away from rotating machinery and moving parts.</p>		<p>ROTATING MACHINERY Stay clear. Keep hands and tools away from rotating machinery.</p>

- The GREEN MACHINE will be installed near locations where highly flammable and explosive gasoline vapors may be present.
- Installation of the GREEN MACHINE must comply with the National Electric Code, federal, state, and local codes, as well as other applicable safety codes.
- Use extreme caution due to the risk of fire or explosion, which could result in serious injury or even death.
- If you are working in an area where vehicle traffic may occur, always block off the work area during installation, testing, and service to protect yourself and others.
- Do not use power tools that can generate sparks if there is a risk of flammable or explosive vapors being present.
- Read and understand all materials related to installing, testing, and operating the GREEN MACHINE prior to installation.

CAUTION: ALL SERVICEABLE / REPLACEMENT PARTS MUST BE OBTAINED FROM VST TO MAINTAIN SUITABILITY FOR A CLASS 1, DIVISION 2 LOCATION.

Table of Terms & Abbreviations

ASC:	Authorized Service Contractor	Permeate:	Air return to atmosphere
ATG:	Automatic Tank Gauge	PMC:	Pressure Management Control
CVLD:	Continuous Vapor Leakage Detection, another name for Vapor Leak Detection	PTO:	Permit to Operate
EVR:	Enhanced Vapor Recovery	P/V Valve:	Pressure Vacuum Valve
GDF:	Gasoline Dispensing Facility	RVP:	Reid Vapor Pressure
GM:	GREEN MACHINE	TLS:	Tank Level System
ISD:	In-Station Diagnostics	TS:	Troubleshooting
MAG Probe:	A type (brand) of Tank Inventory Probe	Ullage:	Vapor space above liquid in a UST
NEC:	National Electric Code	UST:	Underground Storage Tank
NFPA:	National Fire Protection Association	VCK:	Vapor Collection Kit
ORVR:	On-Board Refueling Vapor Recovery	VOC:	Volatile Organic Compounds
OSHA:	Occupational Safety Health Administration	VST:	Vapor Systems Technologies, Inc.
PLC:	Programmable Logic Controller	IWC:	Inches Water Column

Regulations & Jurisdiction

- Under vapor recovery regulations, local and national authorities have primary authority for regulating gasoline stations.
 - Before modifying the facility, gasoline station operators should contact the national and local authorities for specific information and requirements on local vapor-recovery requirements.
 - Be sure to read and understand all site requirements before beginning an installation.
- “The area inside the GREEN MACHINE cover has been evaluated as a Class I, Division 2 hazardous area as defined by the National Electric Code /NFPA 70 Article 514 table 514.3(B)(1) and verified by Intertek”
- Installation of the GREEN MACHINE must comply with (if applicable):
 - Fire Marshal
 - Water Board
 - Local Air Pollution Dist.
 - ICC
 - NEC
 - NFPA 30 and 30A
 - UL/ETL
 - Any other applicable federal, state, and local codes

GREEN MACHINE Overview

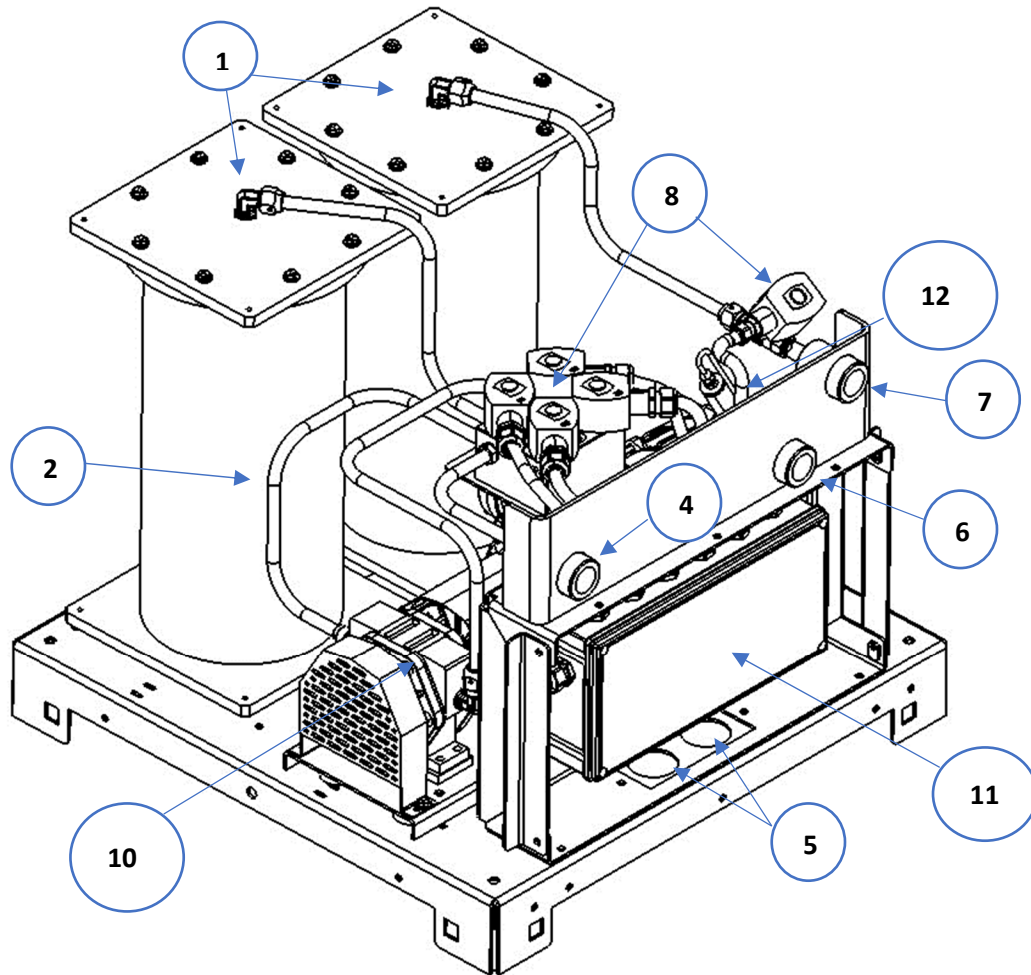

Ref#	Part Name	Part Description
1	Vapor Filtration Cartridges (2)	Captures and cleans VOC's from the vapor emissions
2	Vapor Piping	Piping for the transfer of vapor
3	16/3 AWG Cable (not shown)	Used for installing wires to the pressure sensor
4	1" NPT Vapor Inlet Connection	Port for pulling vapors from the UST
5	Hole for 3/4" Electrical Connection (Connection hardware not supplied)	Conduit connection for wirings from the Control Panel to the GREEN MACHINE™
6	1" NPT Vapor Return Connection	Port for returning vapors to the UST
7	1" NPT Air Outlet Connection	Port for venting air to atmosphere
8	Control Valves (5)	Controls the flow of vapor and air
9	Vac Pump Motor (not shown)	Drives the Vacuum Pump
10	Vac Pump	For transporting vapors to and from the UST
11	Internal Junction Box	Houses all wiring connections from the Control Panel to the GREEN MACHINE™
12	Pressure Sensor	Used to monitor the UST vapor pressure
13	Control Panel (not shown)	Controls the GREEN MACHINE™

GREEN MACHINE Theory of Operation

- The GREEN MACHINE is a vapor processor that operates in two phases. In the first phase, the GREEN MACHINE pulls a mixture of fuel vapor and air from the underground storage tanks through Vapor Filtration Cartridges (2). The vapors are trapped in the Cartridge while the air is allowed to pass through to atmosphere. The second phase of the GREEN MACHINE run process is to create a vacuum on the Vapor Filtration Cartridges (2) to remove the captured vapors, and return these vapors to the underground storage tank. As a result of this entire process, there is a net loss of pressure in the underground storage tank, while minimizing the loss of fuel vapors that would have otherwise been vented to the atmosphere.
- The VST GREEN MACHINE operates based on monitoring the Underground Storage Tank (UST) system pressure.
- The GREEN MACHINE Control Panel provides UST pressure data via a pressure transducer, located in the GREEN MACHINE, and manages the GREEN MACHINE operation.
- The pressure data is provided to the VST Control Panel for system monitoring functions.
- The closed loop vapor piping solution continuously operates the system to control UST pressure below 0.2 IWC.

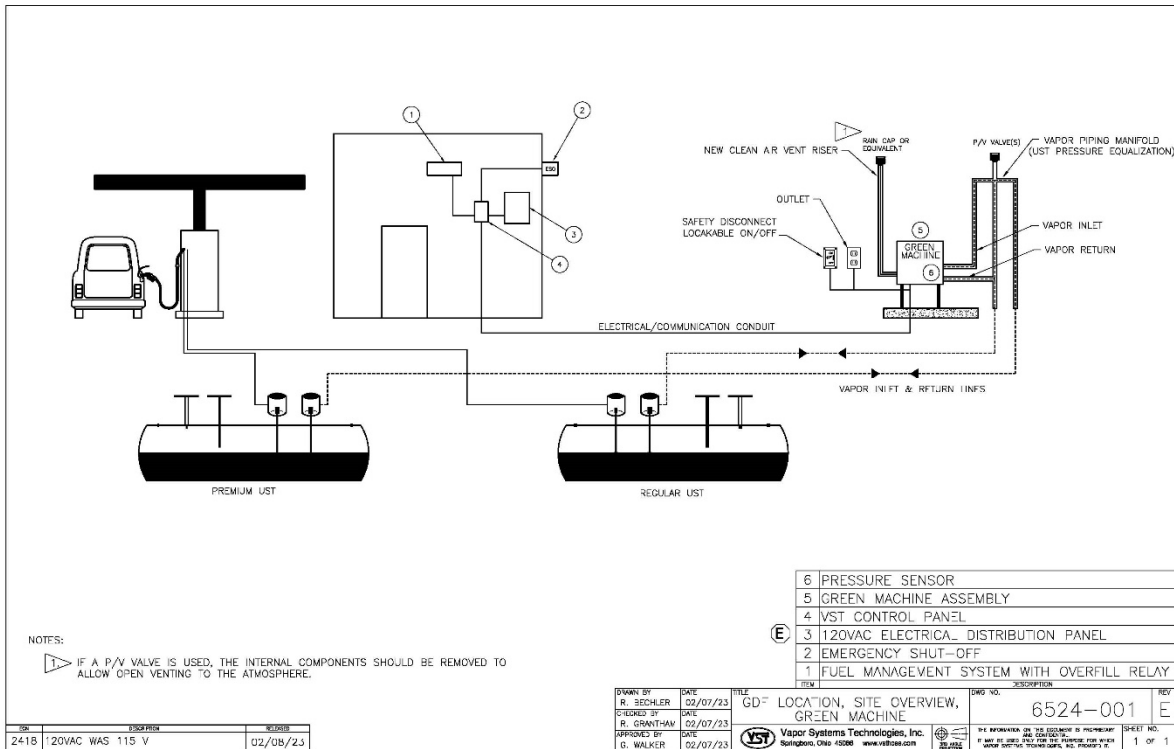

GREEN MACHINE Dimensions & Weight

Unit	Dimensions	Weight
GREEN MACHINE	L-27.2" x W-26.8" x H-46" Height includes 20" legs	203 lbs. w/out Cover w/out Control Panel
Aluminum Cover	L-27.2" x W-26.8" x H-26" (one-piece unit)	11 lbs.
VST Control Panel	L-5.2" x W-11.8" x H-13.5"	11 lbs.

How the GREEN MACHINE is Shipped

- **Verify that all the items are in the shipping crate:**
 - GREEN MACHINE - VST-GM3-CS2A-101
 - Aluminum Cover
 - VST Control Panel
 - (4) 20" Steel Legs
 - (4) Pipe flanges to install the GREEN MACHINE to a concrete pad
 - (1) 0.063" dia. Orifice
 - (3) 1" Brass Full Port Ball Valves, Locking
 - Quick Installation Guide
- **Shipping Check**
 - When you open the container:
 - Verify that all the items are in the shipping container.
 - Visually inspect all the items for any obvious damage.

This page left intentionally blank

Chapter 1: General Contractor Installation

1 Installation Instructions

1.1 Installation Safety for all Contractors



- The GREEN MACHINE will be installed near locations where highly flammable and explosive gasoline vapors may be present.
- Installation of the GREEN MACHINE must comply with the National Electric Code, federal, state, and local codes, as well as other applicable safety codes.
- Use extreme caution due to the risk of fire or explosion, which could result in serious injury or even death.
- If you are working in an area where vehicle traffic may occur, always block off the work area during installation, testing, and service to protect yourself and others.
- Do not use power tools that can generate sparks if there is a risk of flammable or explosive vapors being present.
- Read and understand all materials related to installing, testing, and operating the GREEN MACHINE prior to installation.

1.2 Preparing the GREEN MACHINE for Installation

Follow these steps to prepare the GREEN MACHINE for installation:

1. Verify that all the items are in the shipping crate:
 - GREEN MACHINE - VST-GM3-CS2A-101
 - Aluminum Cover
 - VST Control Panel
 - (4) 20" Steel Legs
 - (4) Pipe flanges to install the GREEN MACHINE to a concrete pad
 - (1) 0.063" dia. Orifice
 - GREEN MACHINE Quick Installation Guide
2. Visually inspect all the items for any obvious damage.
3. **CAUTION:** Unpack and install the four legs on the GREEN MACHINE prior to transporting to the installation site. Installing the legs on site without proper support may cause damage to the unit.

1.3 Installing the Legs on the GREEN MACHINE

1. Support the GREEN MACHINE with a forklift or a set of saw horses so the legs can be installed.
2. Install the 4 legs on the GREEN MACHINE. Screw on each flange to each leg and then screw on each leg to the base.

1.4 GREEN MACHINE Dimensions & Weight

Unit	Dimensions	Weight
GREEN MACHINE	L-27.2" x W-26.8" x H-46" Height includes 20" legs	203 lbs. w/out Cover w/out Control Panel
Aluminum Cover	L-27.2" x W-26.8" x H-26" (one-piece unit)	11 lbs.
VST Control Panel	L-5.2" x W-11.8" x H-13.5"	11 lbs.

1.5 Ground Mount Locations

- NOTE: Minimum vapor-piping slope must always be maintained for all GREEN MACHINE mounting options.
 - VST requires a minimum slope of ¼" per foot on all vapor piping away from the GREEN MACHINE to the vent risers.
 - Select a location for the concrete pad next to the vent risers to minimize piping and pressure drop.
- The GREEN MACHINE must be protected from damage:
 - Install bollards or another suitable method to protect the GREEN MACHINE.
- VST recommends a clear 18" perimeter around the GREEN MACHINE for maintenance and testing.
- The GREEN MACHINE must be located within 100 feet of the vent risers.
- To minimize the installation cost and to maximize operating efficiency, locate the GREEN MACHINE adjacent to the existing vent risers.
- A new air outlet vent riser connected to the GREEN MACHINE must be installed to release air to the atmosphere.
- VST recommends setting the GREEN MACHINE on a concrete pad with the following minimum dimensions: 36" long x 36" wide, 6" thick.
 - Install the concrete pad as outlined in this manual.
- Follow the local jurisdiction's building codes.
- VST does not provide any hardware to install the GREEN MACHINE on the pad.

1.6 Setting the Concrete Pad

- The soil must have the following capabilities:
 - Allowable bearing pressure: 1000 psf
 - Lateral bearing: 150 psf
 - Coefficient of sliding: 0.25
- The GREEN MACHINE must be installed on a concrete pad, on grade, and permanently anchored to the concrete pad.
 - Install the concrete pad level.
 - Use steel re-enforced rebar in the pad for additional strength.
 - The GREEN MACHINE CANNOT be installed directly on or anchored directly to asphalt. It must be installed and anchored directly to a concrete pad.
- The GREEN MACHINE can be installed on an existing concrete pad, provided:
 - The existing concrete is of sufficient strength and thickness to support the GREEN MACHINE.
 - VST recommends a minimum of 6" thick concrete to accommodate 4 1/2" expansion-type anchor bolts.
 - Cracked concrete without re-bar may NOT be of sufficient strength to properly support the GREEN MACHINE.
 - The GREEN MACHINE is installed level.
 - NOTE: VST CANNOT BE HELD RESPONSIBLE FOR DAMAGE CAUSED BY IMPROPER GREEN MACHINE FOUNDATION SUPPORT.
- VST does not provide any hardware to install the GREEN MACHINE on the pad.
- VST recommends using an 18" minimum clearances around the perimeter of the GREEN MACHINE for maintenance and service.
- Concrete pad minimum dimensions:
 - 36" long x 36" wide
 - 6" thick (minimum)
 - **See Figures 1-1 and 1-2**
- Install expansion-type bolts after completing the concrete pad. The bolts must be:
 - 1/4" diameter
 - Embedded 3" into the slab
 - Extend approx. 1-1/4" above the top of the slab

1.7 Installing the GREEN MACHINE on the Concrete Pad

- After the concrete has properly cured, install the expansion anchor bolts according to the manufacturer's recommendations. **See Figures 1-1 and 1-2.**
- For applications that require expansion anchors that are especially suited to seismic and cracked concrete, VST recommends using the HILTI KWIK TZ (KB-TZ) BOLT, KB-TZ2 1/4" X 4 1/2", (item number 2210176) or approved equal.
- The contractor or design engineer is responsible for sizing the expansion anchors and the concrete pad to meet seismic and cracked concrete specifications required by local, state, and federal jurisdictions.
 - Since seismic regulations may be different by location, VST has not included a specific drawing for this application.
 - For seismic design reference, www.us.hilti.com.
- After the appropriate anchor bolts have been installed, position the GREEN MACHINE onto the anchor bolts in the cement slab.
- Bolt the GREEN MACHINE into place (according to the manufacturer recommended installation guidelines) with 1/4" galvanized lock washers and bolts

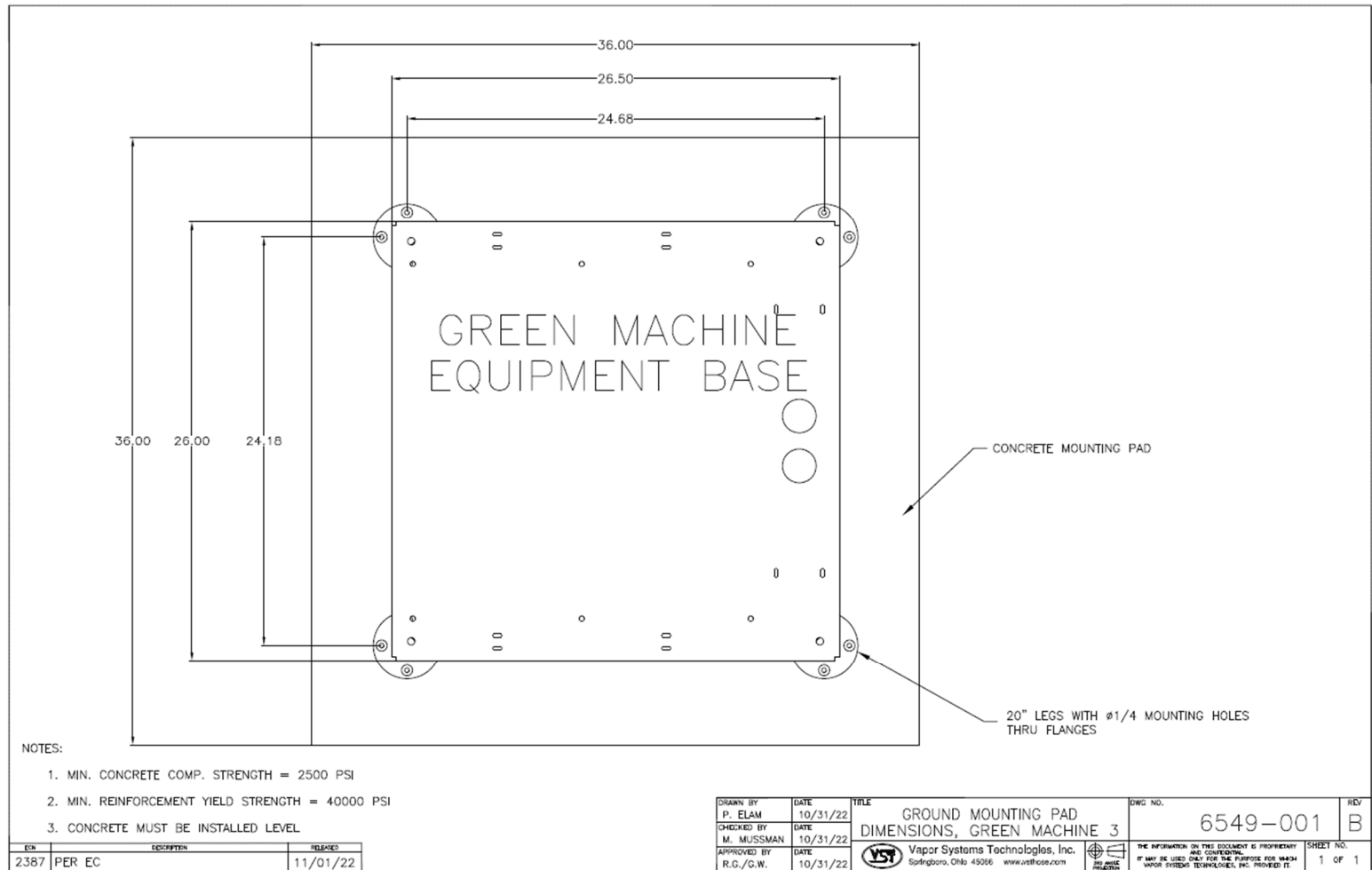

Figure 1-1: Concrete mounting pad dimensions

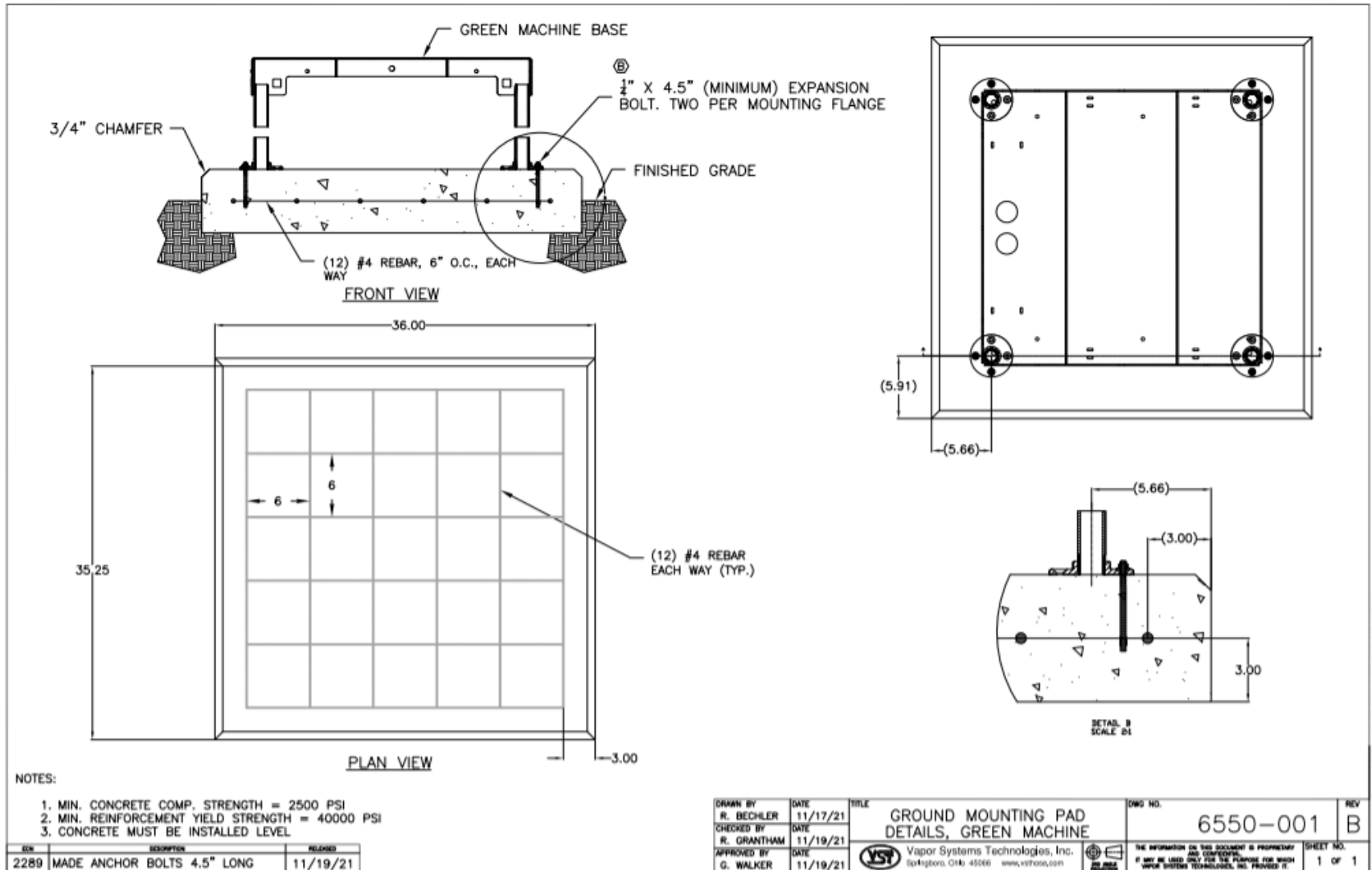

Figure 1-2: GREEN MACHINE Ground Mounting Pad

1.8 Roof-Top Installation

- NOTE: Minimum vapor-piping slope must always be maintained for all GREEN MACHINE mounting options.
 - VST requires a minimum slope of $\frac{1}{4}$ " per foot on all vapor piping away from the GREEN MACHINE to the vent risers.
- The GREEN MACHINE may be installed on a station's roof provided the structure can support the weight of the GREEN MACHINE.
- All safety and code concerns must be taken into consideration prior to a roof-top installation.
- Due to a variety of roof construction designs, VST cannot recommend how the GREEN MACHINE should be mounted on the roof; however, the GREEN MACHINE must be installed at a height allowing the piping inlet and outlets to be above or through the building parapet.
- The GREEN MACHINE has 20" legs that can be attached to the base, but the legs may be removed and the GREEN MACHINE secured to a steel structure attached to the roof.
- A new air outlet vent riser connected to the GREEN MACHINE must be installed to release air to the atmosphere.
- A Design Engineer is responsible for designing the support structure, support base, all required hardware and bolting connections, and the support structure foundation to meet all regulatory specifications that may be required by local jurisdictions.

1.9 Canopy-Top Installation

- NOTE: Minimum vapor-piping slope must always be maintained for all GREEN MACHINE mounting options.
 - VST requires a minimum slope of $\frac{1}{4}$ " per foot on all vapor piping away from the GREEN MACHINE to the vent risers.
- The GREEN MACHINE may be installed on a station's canopy provided the structure can support the weight of the GREEN MACHINE.
- Due to a variety of canopy construction designs, VST cannot recommend how the GREEN MACHINE should be mounted on the canopy.
- All safety and code concerns should be taken into consideration prior to a canopy-top installation.
- The GREEN MACHINE has 20" legs that can be attached to the base, but the legs may be removed and the GREEN MACHINE secured to a steel structure attached to the canopy support structure.

Canopy-Top Installation, continued...

- A new air outlet vent riser connected to the GREEN MACHINE must be installed to release air to the atmosphere.
- A Design Engineer is responsible for designing the support structure, support base, all required hardware and bolting connections, and the support structure foundation to meet all regulatory specifications that may be required by local jurisdictions.

1.10 Vent-Stack Mount Installation

- NOTE: Minimum vapor-piping slope must always be maintained for all GREEN MACHINE mounting options.
 - VST requires a minimum slope of $\frac{1}{4}$ " per foot on all vapor piping away from the GREEN MACHINE to the vent risers.
- The GREEN MACHINE may be installed elevated on the existing vent risers provided there is an existing structure that can support the weight of the GREEN MACHINE, or a structure can be installed to support the weight of the GREEN MACHINE.
- Due to a variety of construction designs, VST cannot recommend how the GREEN MACHINE should be installed or mounted on a vent riser support structure; however, the structure that supports the GREEN MACHINE must be designed and installed at a height allowing the piping inlet and outlets to connect to the existing vent risers.
- The GREEN MACHINE has 20" legs that can be attached to the base, but the legs may be removed for the GREEN MACHINE to be secured to a steel support structure.
- A new air outlet vent riser connected to the GREEN MACHINE must be installed to release air to the atmosphere.
- All safety and code concerns must be taken into consideration prior to vent stack mount installation.
- A Design Engineer is responsible for designing the support structure, support base, all required hardware and bolting connections, and the support structure foundation to meet all regulatory specifications that may be required by local jurisdictions.
- **See Figure 1-3** for illustration.

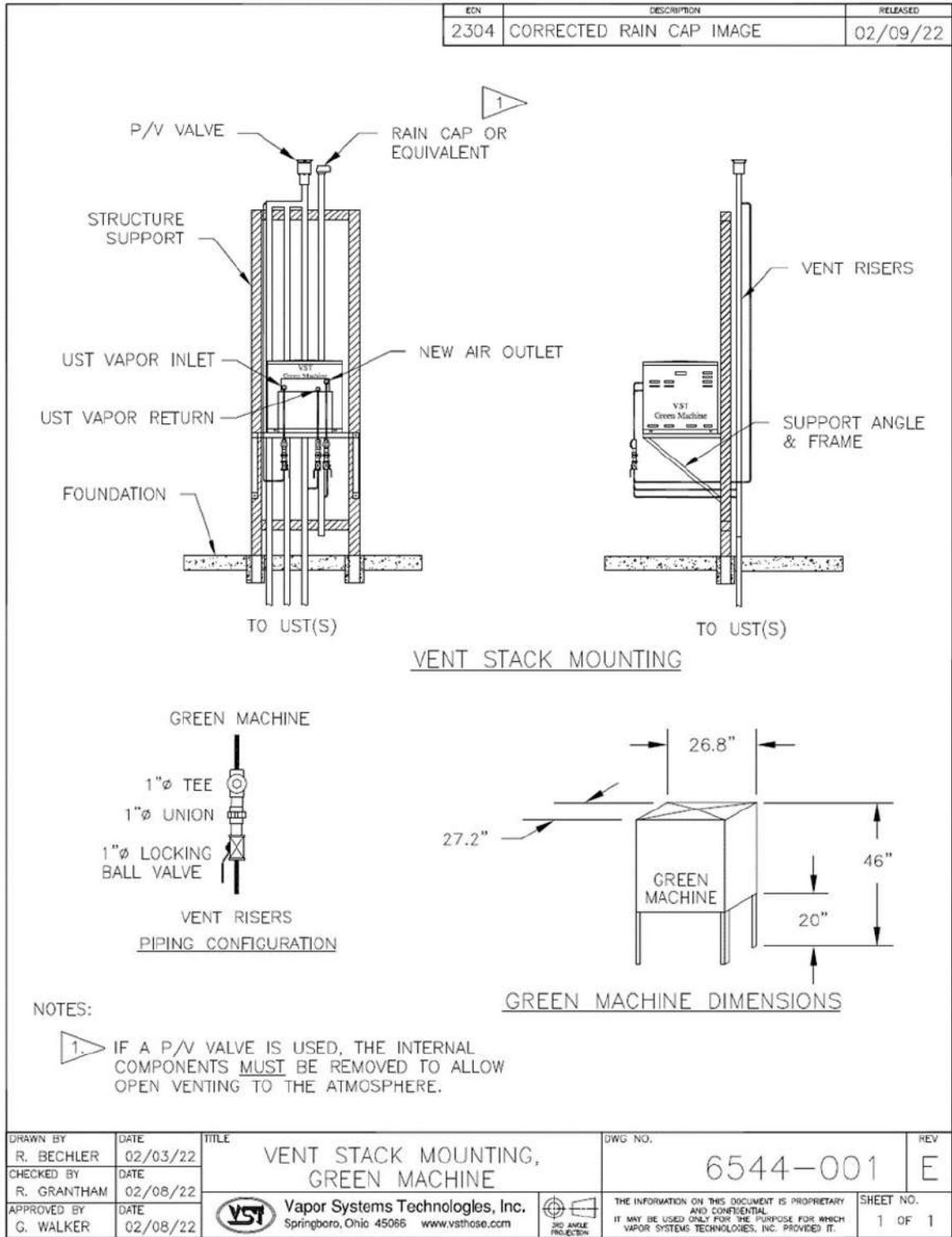

Figure 1-3: Vent Stack Installation

This page left intentionally blank

Chapter 2: Vapor Piping Installation

2 Vapor Piping Installation Overview

- There are 3 piping connections to be made to the GREEN MACHINE. **See Figures 2-1 & 2-2:**
 - Vapor Inlet (supply) from the UST's
 - Vapor (concentrate) Return to the UST's
 - Air Outlet to atmosphere
- All the GREEN MACHINE piping connections are 1" diameter National Pipe Thread (NPT).

2.1 General Notes

- The piping contractor is responsible for providing all necessary piping, non-hardening pipe-joint compound or Gasoline Resistant Teflon (yellow) Tape, and pipe fittings.
- Make sure the gasoline UST tanks vapor piping is manifolded either above ground or below ground.
- Locks must be installed on the valves between the GREEN MACHINE and vent risers to prevent unauthorized tampering of the equipment.
- Under normal operation, the valves must be locked in the OPEN position.
- VST requires a minimum slope of 1/4" per foot on all vapor-piping away from the GREEN MACHINE to the vent risers or to any other UST piping connection.
- The 1/4" diameter drain line with the supplied adapter must be installed per **Figure 2-1**.

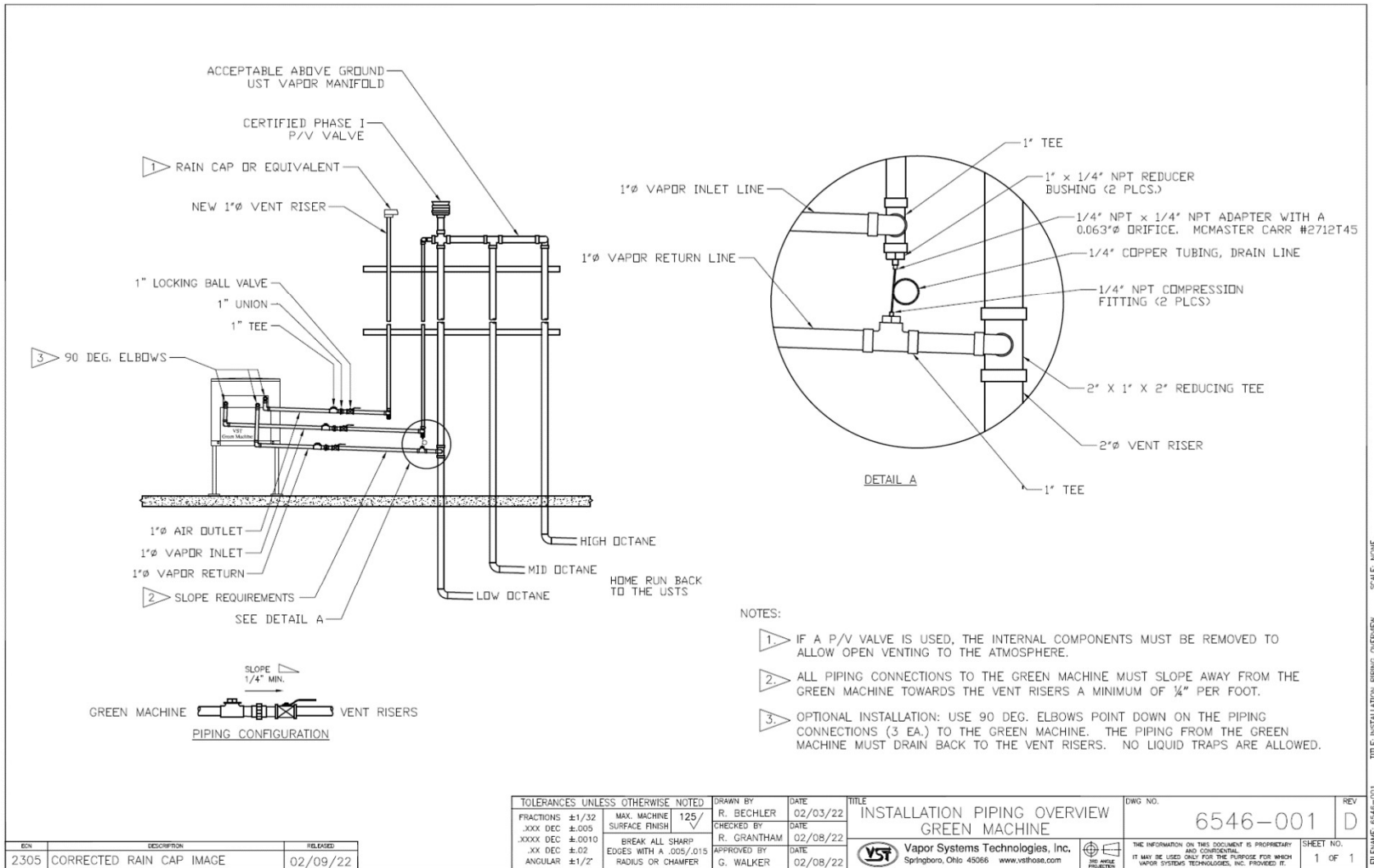

Figure 2-1: Vapor Piping Overview

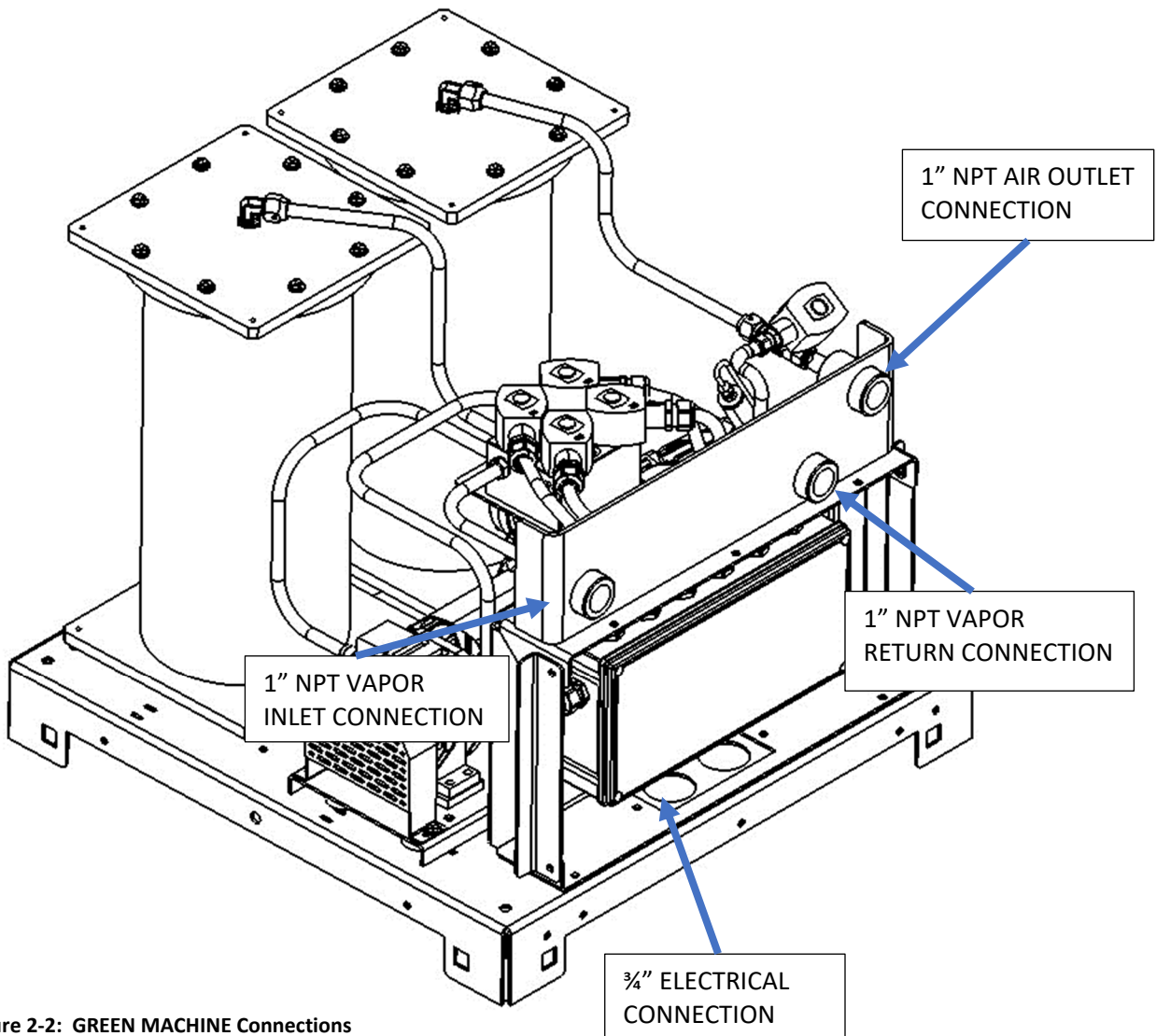

Figure 2-2: GREEN MACHINE Connections

2.2 Flexible Piping

- If flexible piping is required by the local authority to meet seismic requirements, install the flexible piping between the GREEN MACHINE locking ball valve and the vent riser(s).
- The flexible connector must be approved for a service station above-ground application.
- Support the flexible piping per manufacturer's recommendation.
- The slope of the flex connection from the GREEN MACHINE back to the vent riser must be a minimum of 1/4" per foot slope.
- Liquid traps are not allowed.

2.3 Vapor Inlet and Vapor Return Piping Installation

- Install a 1" vapor inlet pipe and a 1" vapor return pipe as shown in **Figure 2-1** from the vapor inlet and vapor return connections on the GREEN MACHINE to an existing vent riser.
- An existing vent riser that connects to the GREEN MACHINE must be modified by:
 - Adding the first tee (near the bottom of the vent riser) for connecting the 1" vapor return pipe. The first tee must be installed to allow the vapor return to slope away from the GREEN MACHINE.
 - Adding a second tee/cross (just below the P/V valve) for connecting the 1" vapor inlet pipe. The second tee/cross must be installed at the top of the vent riser, but below the P/V valve.
- Both the vapor inlet and the vapor return lines have: a 1" union, a 1" locking ball valve, and a 1" tees/caps, and any other piping fittings to complete the installation.
- The 1" vapor return pipe connecting to the bottom of the vent riser **MUST BE INSTALLED** below the 1" vapor inlet pipe that connects to the top of the vent riser.
- A ¼" drain line **MUST BE INSTALLED** between the vapor inlet and the vapor return so any condensate from the vapor inlet line can drain into the vapor return line. VST is supplying a ¼" NPT x ¼" NPT adapter with a 0.063 orifice. The orifice will eliminate any vapor flow between the vapor inlet line and the vapor return line.
- Install a tee into the vent riser that will connect to the GREEN MACHINE Vapor Inlet using 1" NPT pipe.
- The new tee must be installed to allow for slope away from the GREEN MACHINE to the vent riser.
- If there are multiple-grade UST's and multiple vent risers, VST recommends connecting the GREEN MACHINE to the lowest octane vent riser.
- From the vent riser, install the 1" locking ball valve, then the 1" union, then the 1" tee.
See Figure 2-1.

2.4 Air Outlet Piping Installation

- Install a new vent riser next to an existing vent riser (if possible).
 - The 1" piping must slope away from the GREEN MACHINE a minimum of ¼" per foot. **See Figure 2-1.**
- Install the new dedicated vent riser so that the discharge opening is at least as high as the existing riser and a minimum of 1" diameter.
- Install a tee with a cap at the bottom of the new air outlet vent riser to provide for manual drainage.
- Make sure the ¼" drain line is installed between the vapor inlet and the vapor return lines.
- Install piping from the 1" NPT Air Outlet fitting on the GREEN MACHINE to the new vent riser.
- From the vent riser, install the 1" locking ball valve, then the 1" union, then the 1" tee as shown in **Figure 2-1.**
- A rain cap or equivalent must be installed on the new air outlet vent riser.
 - If a PV vent valve is used, the internal components must be removed to allow open venting to the atmosphere.

2.5 Vapor Piping Post-Installation

- After all the piping has been installed, make sure the 3 lockable ball valves are locked and in the OPEN position.
- Make sure all the pipe connections are tight.
- Make sure the slope is a minimum 1/4" per foot away from the GREEN MACHINE to the vent risers.
- Make sure there are no traps between the GREEN MACHINE and the vent risers.
- If flex piping is used, make sure the flexible piping is adequately supported.
- The ¼" diameter drain line with the supplied adapter must be installed per **Figure 2-1.**

2.6 Vapor Piping Bill of Material

Contractor Supplied
1" diameter straight tees with caps
1" diameter unions
Straight tee (sized to match existing vent riser)
Straight tee with cap (sized to match new vent riser)
1" diameter pipe, elbows, and misc. pipe fittings
Vent Stack pipe supports and hardware (as required)
¼" NPT Compression Fittings (2 each)
1" x ¼" NPT Reducer Bushing
¼" Diameter Copper Tubing
(3) Locks (for 3-Ball Valves)
Vapor Systems Technologies Supplied
¼" x ¼" NPT Brass Adapter, with a 0.063" diameter orifice
(3) 1" Brass Full Port Ball Valves, Locking
Rain cap (for the new air outlet vent riser)

This page left intentionally blank

3.2 Electrical Installation

- The VST Control Panel and the GREEN MACHINE Internal Junction Box arrive from the factory pre-wired and completely tested.
- The Electrical Contractor is responsible for supplying all additional wires, conduits, fittings, seal-offs, outlets, and the Safety Disconnect Switch required to install the GREEN MACHINE and meet regulation requirements and standards.
- All wiring must be gasoline and oil resistant.
- A LOCKABLE SAFETY DISCONNECT-SWITCH MUST BE INSTALLED BY THE GREEN MACHINE:
 - Must be wired per included drawings.
 - Should be installed within eye-sight of the GREEN MACHINE for safety reasons.
 - Must not be installed within 3 feet of the GREEN MACHINE.
 - Consult the NEC for restrictions, location, and type of disconnect.
- The GREEN MACHINE is installed in a Class I, Division 2 hazardous location and therefore requires electrical seal-offs when connecting to ordinary, non-hazardous electrical locations. Consult the NEC and NFPA for installation instructions.
- All wiring (120 VAC and 24 VDC) to be TFFN or THHN with 600V insulation.
- The contractor is responsible for sizing the wire, cable, and conduit according to the NEC.
- All power wires connected to the GREEN MACHINE will be disconnected when:
 - The station Emergency Shut-Off is activated.
 - The Safety Disconnect Switch at the GREEN MACHINE is turned off.
 - Power is turned OFF to the VST Control Panel at the electrical distribution panel.
- CAUTION: SAFETY PRECAUTION
 - **BE SURE THE GREEN MACHINE BREAKER INSIDE THE ELECTRICAL PANEL IS LOCKED OUT/TAGGED OUT PRIOR TO THE INSTALLATION.**

3.3 Electrical Installation Code Requirements

- According to NFPA 30:
 - “Electrical wiring and electrical utilization equipment shall be a type specified by and be installed in accordance with NFPA 70. Electrical wiring and electrical utilization equipment shall be approved for the locations in which they are installed.”
- All electrical wiring and electrical utilization equipment must be installed to meet federal, state, and local codes.
- Flexible electrical conduit connections to the GREEN MACHINE may be required by local jurisdictions to meet code requirements.
- Following such procedures may be required by local, state, and national authorities.
 - You must install the GREEN MACHINE in accordance with the National Electric Code (NEC), NFPA 70, and with the Automotive and Marine Service Station Code (NFPA 30A).
 - According to NFPA 30A:
 - “Electrically energized vapor-recovery equipment shall be directly connected to and controlled by the Emergency Shut Off (ESO) in Section 5202.4.7.”

3.4 Electrical Components

Existing Components	VST Supplied Components	Contractor Supplied Components
120V Main Electrical Panel	Pre-wired VST Control Panel	120V Outlet (For maintenance and testing)
Fuel Management System (TLS-350/450) or other	Pre-wired GREEN MACHINE Internal Junction Box	Lockable Safety Disconnect-Switch
Overfill Alarm Output Relay (4-Relay Module)		All conduit, wire, cable, fittings, and seal-offs, and any other electrical material to complete the electrical installation
Emergency Shut-Off (ESO)		Emergency Shut-Off (ESO) Relay if needed (20A, SPDT)

Table 2: Table of Electrical Components

3.5 Electrical Wiring Installation

SAFETY PRECAUTION: PRIOR TO STARTING ANY ELECTRICAL WORK, BE SURE TO USE LOCK OUT / TAG OUT PROCEDURES.

Wires Required to install the GREEN MACHINE:

9 WIRES AND 1 CABLE FROM THE VST CONTROL PANEL TO THE GREEN MACHINE INTERNAL JUNCTION BOX

1. 1 Vacuum Pump 120 VAC Hot
2. 1 Common Neutral
3. 1 Common Ground
4. 1 Control Valve V1 120 VAC Hot
5. 1 Control Valve V2 120 VAC Hot
6. 1 Control Valve V5 120 VAC Hot
7. 1 Safety Switch 120 VAC Hot
8. 1 Safety Switch Leg 120 VAC Hot
9. 1 Safety Switch Ground
10. 1 Cable, 3 conductors, 18 AWG, twisted pair, shielded ground

IN ADDITION, THERE ARE 3 WIRES FOR THE 120 VAC OUTLET FROM THE ELECTRICAL DISTRIBUTION PANEL

1. 1 Outlet 120 VAC Hot
2. 1 Outlet Neutral
3. 1 Outlet Ground

3.5.1 Installing the VST Control Panel:

- The contractor must drill holes in the VST Control Panel for all wiring connections.
- Install the VST Control Panel only inside the GDF. The location may vary within the GDF given the allowable space.
- When possible, place the VST Control Panel as close to the Fuel Management System as possible.
- After the Control Panel is installed and power applied to the panel, **Figure 3-1** shows the Main Screen with the GM DISABLED – ENTER CODE label, which will be discussed later in this Chapter.



Figure 3-1: Main Screen with GREEN MACHINE DISABLED: ENTER CODE

3.5.2 Power The VST Control Panel from The Station Emergency Shut-Off (ESO) Relay.

Figures 3-3, 3-4: Electrical Overview Drawings for Reference

Supply Power to the GREEN MACHINE from the ESO Relay:

1. Make sure the ESO Relay is 20A or higher.
2. Install the 120 VAC power, the neutral, and the ground wires from the ESO Relay to the VST Control Panel.
 - ESO L1 120 VAC Hot to Wire Number 02011
 - ESO Neutral to Wire Number 02012
 - ESO Ground to Ground

3.5.3 Wiring the Electrical Components at the GREEN MACHINE Location.

Figure 3-5: Shows the Field Wiring from the VST Control Panel to the GREEN MACHINE Internal Junction Box: Vacuum Pump Motor, Pressure Sensor, Safety Disconnect Switch

1. Wiring the Internal Junction Box
 - a. Install 6 wires from the VST Control Panel to the junction box
 - a. Vacuum Pump 120 VAC to wire number 02054
 - b. Vacuum Pump Neutral to wire number 02012
 - c. Control Valve V1 120 VAC to wire number 02071
 - d. Control Valve V2 120 VAC to wire number 02072
 - e. Control Valve V5 120 VAC to wire number 02080
 - f. Ground to Ground
2. Pressure Sensor Cable
 - a. Install 1-Pressure Sensor Cable from the VST Control Panel to the Internal Junction Box
 - b. The cable is supplied by the contractor
 - c. The cable must be 3-conductor, 18 AWG, twisted and shielded
 - 24 VDC (+) to wire number 03030
 - 4-20 mA SIGNAL to wire number 04040
 - Shielded ground (Lead wire is a bare ground)
3. Safety Disconnect Switch
 - a. Install 2 wires from the VST Control Panel to the Safety Disconnect Switch
 - 120 VAC to wire number 02011
 - 120 VAC switch leg to wire number 02020
 - Ground to Ground

3.5.4 Wiring the Overfill Alarm Field Wiring

Figure 3-5: Shows the Overfill Alarm Field Wiring from the VST Control Panel to the Fuel Management System

1. The VST Control Panel supplies 24 VDC to an Overfill Alarm relay.
2. The Overfill Alarm output relay is a “dry” relay (N.C.) that shuts down the GREEN MACHINE when a UST reaches the Overfill Level volume during a fuel drop.
3. Install two shielded wires from the VST Control Panel to the Fuel Management System Overfill Alarm (N.C.) output relay. (Refer to the Fuel Management System Installation Manual for connecting and configuring the correct relay. Programming of the Overfill Relay will be completed by a certified technician.)
 - a. TLS-350 or equivalent Overfill Alarm Relay Circuit.
 - b. Connect to the COMM Bay, 4-Relay Module
 - 24 VDC (+) to wire number 03030
 - 24 VDC (signal) to wire number 05050

OR

 - c. TLS-450 PLUS or equivalent Overfill Alarm Relay Circuit
 - d. Connect to the Module Bay, I/O Module
 - 24 VDC (+) to wire number 03030
 - 24 VDC (signal) to wire number 05050

3.5.5 Wiring the VST Control Panel to the GREEN MACHINE

Figure 3-8: Wires from the VST Control Panel to the GREEN MACHINE Internal Junction Box Wiring Diagram.

1. This drawing is used for wiring from the VST Control Panel to the Internal Junction Box for the Vacuum Pump Motor, the 5-control valves, and the Pressure Sensor. For Reference.

3.5.6 Wiring the Pressure Sensor

Figure 3-9: Wiring Diagram of the Pressure Sensor.

1. This drawing is used for wiring from the Internal Junction Box to the Pressure Sensor located inside the GREEN MACHINE cover.

3.5.7 Applying Power to the VST Control Panel

After all the wiring connections listed below are completed and checked, power can be turned ON at the VST Control Panel. The following items have been installed and wired:

1. VST Control Panel
2. Emergency shut-Off Relay
3. Overfill Alarm Relay
4. GREEN MACHINE Internal Junction Box
5. Pressure Sensor
6. Safety Disconnect Switch
7. Outlet

After power is turned ON to the VST Control Panel (See **Figure 3-1**), the Main Screen will show **GM DISABLED – ENTER CODE**. This means:

1. The VST Control Panel has power through the ESO Relay.
2. The GREEN MACHINE cannot operate because Testing & Start-Up has not been completed.
3. The GREEN MACHINE cannot be started by the Electrical Contractor.
4. See **Figure 3-1**: VST Control Panel PLC Main Screen – GM Disabled – Enter CODE Main Screen

Before turning OFF power the VST Control Panel, check to make sure there are no GREEN MACHINE or PRESSURE Alarms.

On the Main Screen, push the Faults & Alarms button. This will bring up the Alarms Screen.

All the items on the screen should be green, indicating there are no alarms present. See **Figure 3-5**.

GREEN MACHINE ALARMS

- A. Vac Pump Alarm
- B. Panel Power Alarm
- C. Overfill Alarm
- D. Digital Storage Alarm

PRESSURE ALARMS

- E. UST Pressure < -6.00 IWC Alarm
- F. UST Pressure > +2.00 IWC Alarm
- G. UST 0.00 +/- 0.15 IWC Alarm
- H. UST VAR. +/- 0.20 Alarm
- I. PRESSURE SENSOR Alarm
- J. 72 HR SHUTDOWN Alarm if any pressure alarm persists as described in the Vapor Recovery Regulations

If an Alarm is present, call Vapor Systems Technologies at 937-704-9333 for instructions.

CAUTION: TURN OFF POWER TO THE VST CONTROL PANEL AT THIS TIME.



Figure 3-2: VST Control Panel PLC Alarm Screen

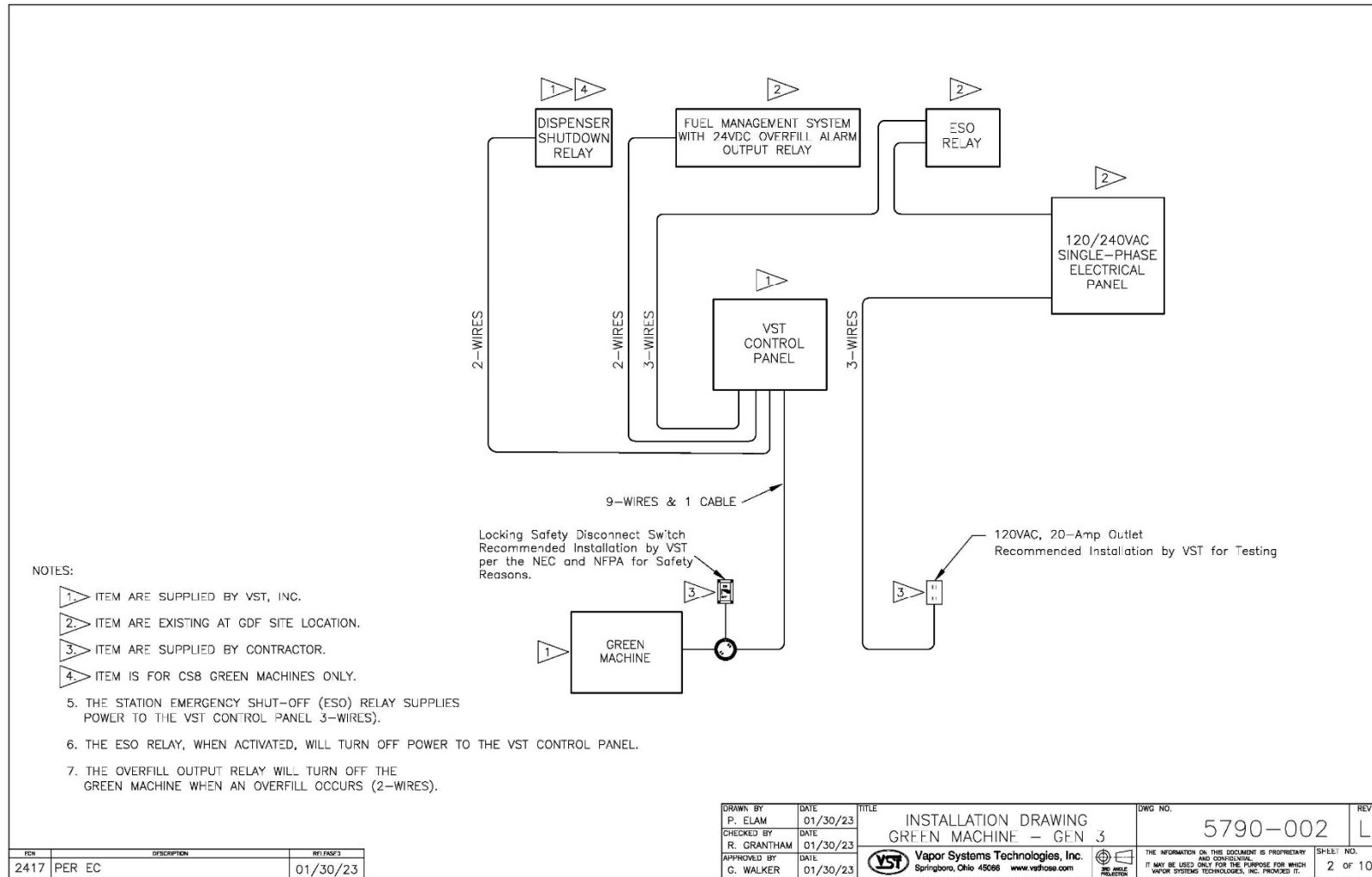

Figure 3-3: The GREEN MACHINE Installation Overview

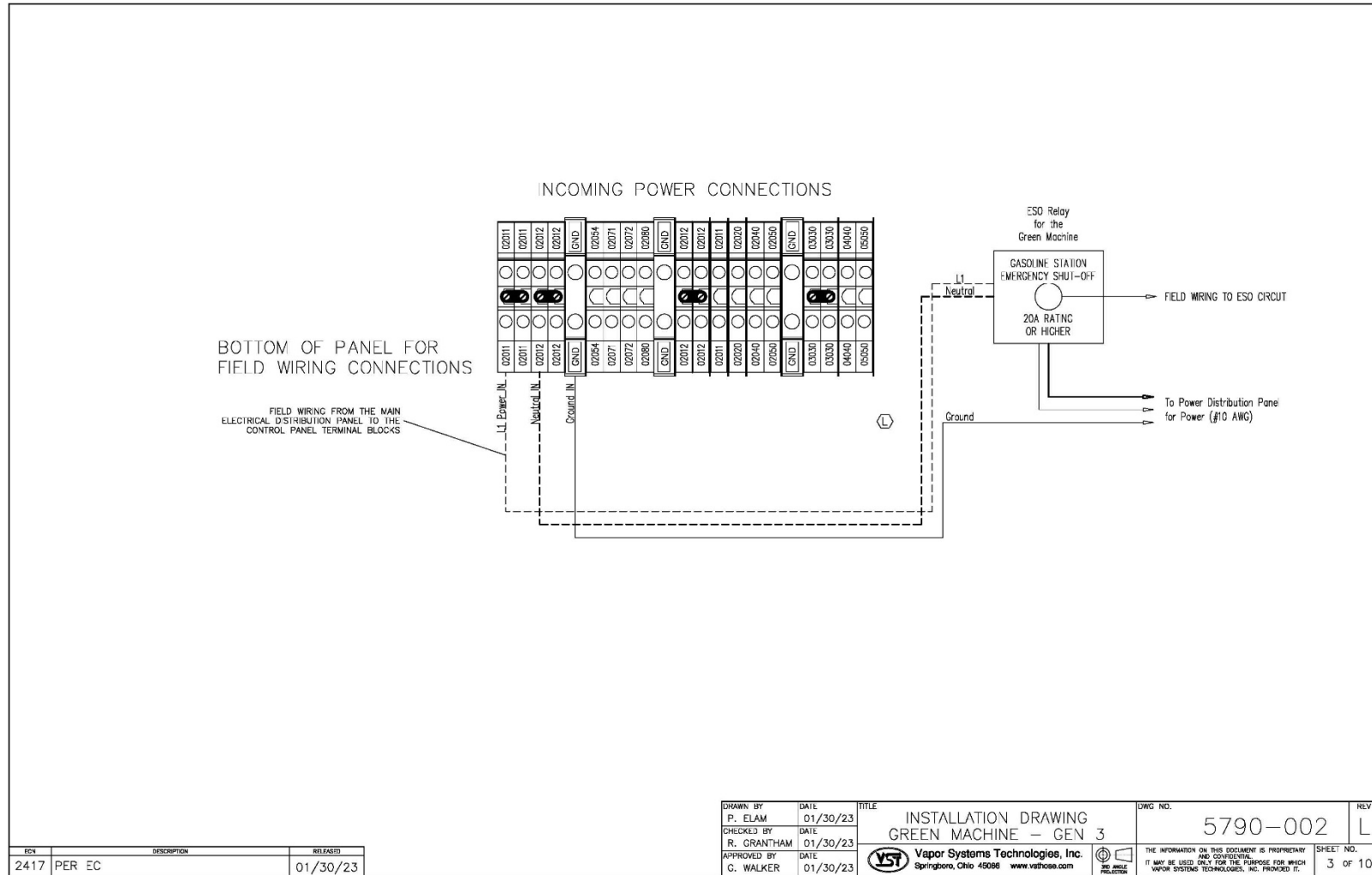

Figure 3-4: The Control Panel Power Connection

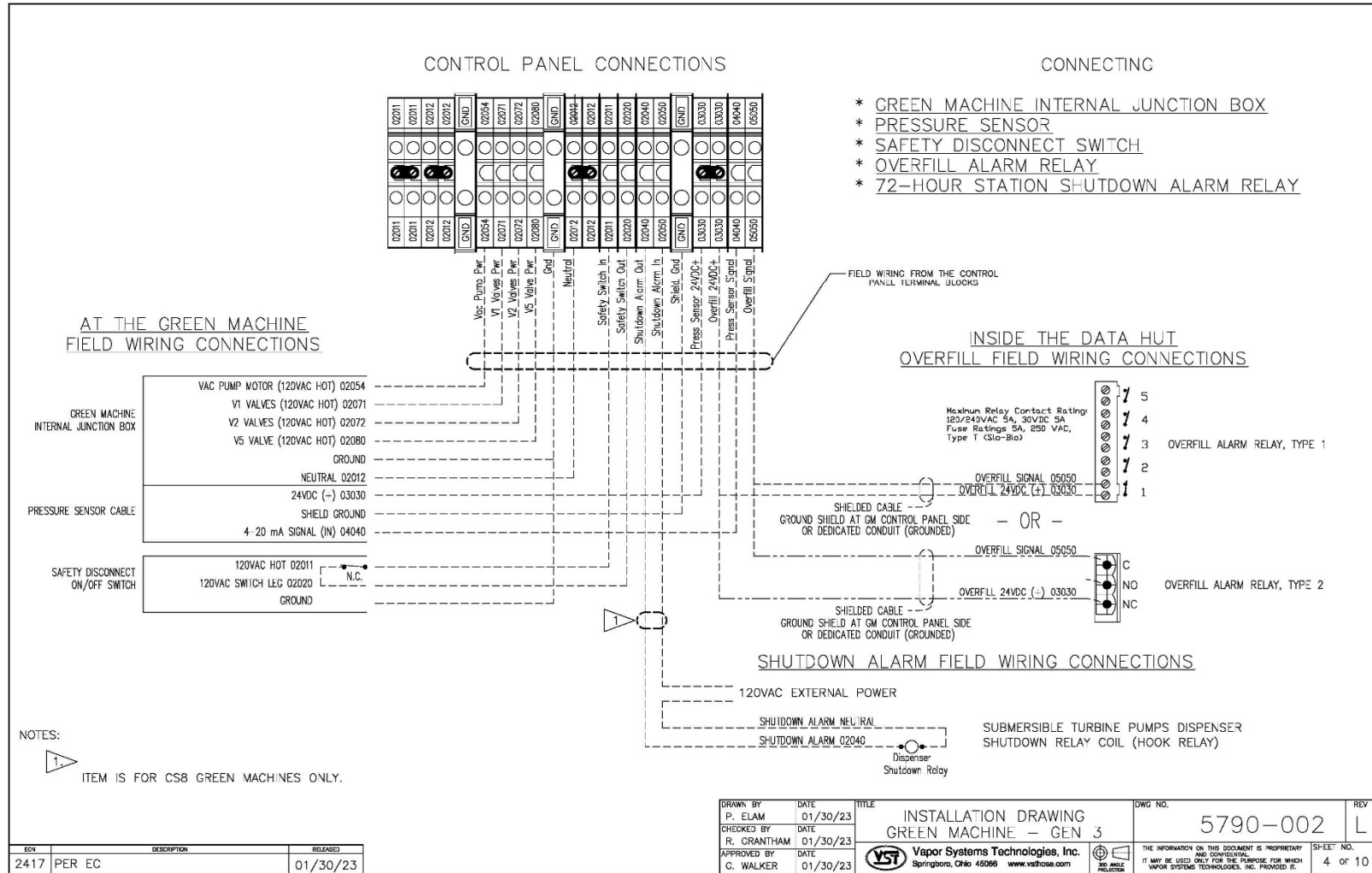

Figure 3-5: The VST Control Panel Field Wiring

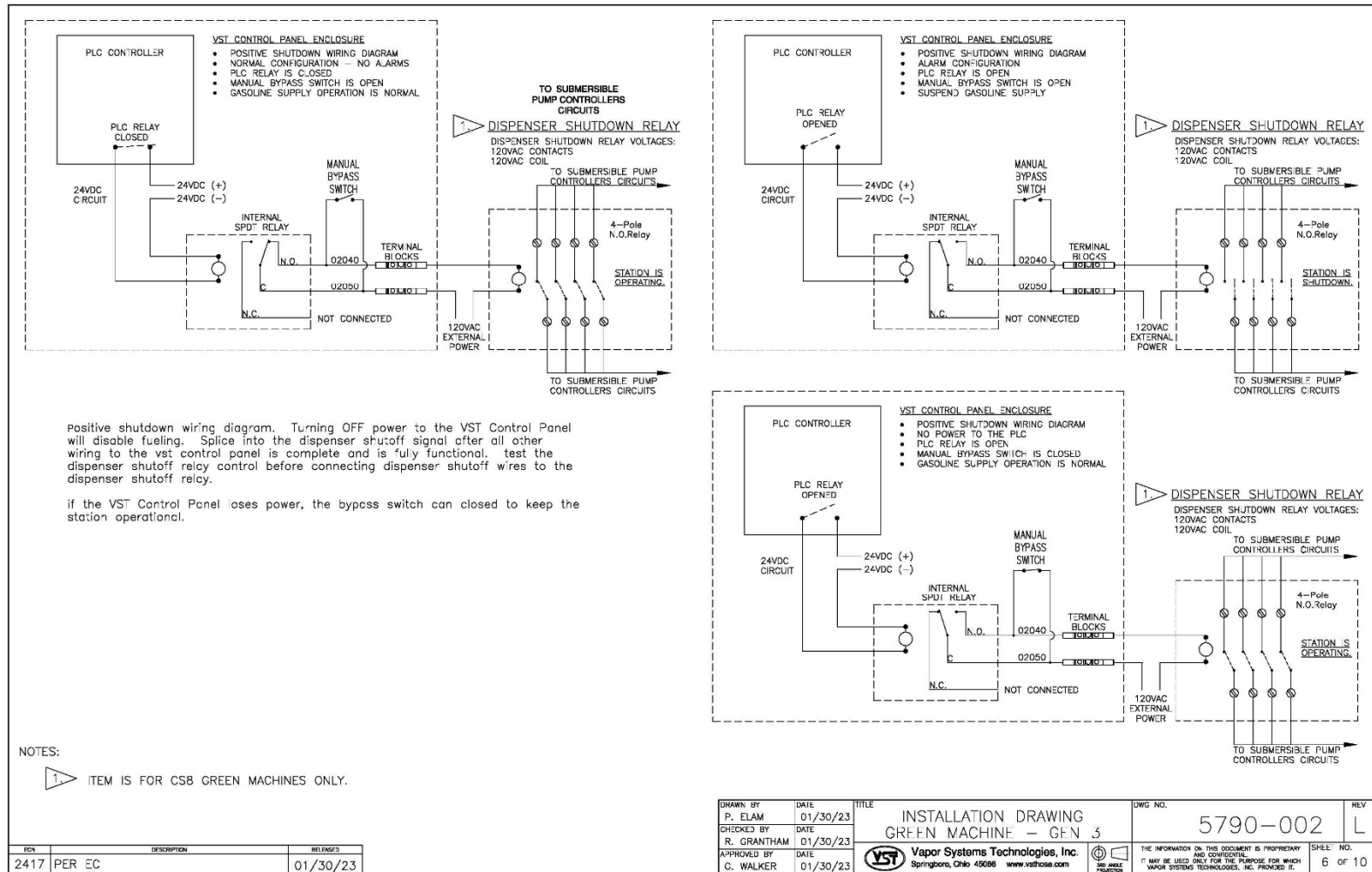

Figure 3-7: GREEN MACHINE Dispenser Shutdown Field Wiring

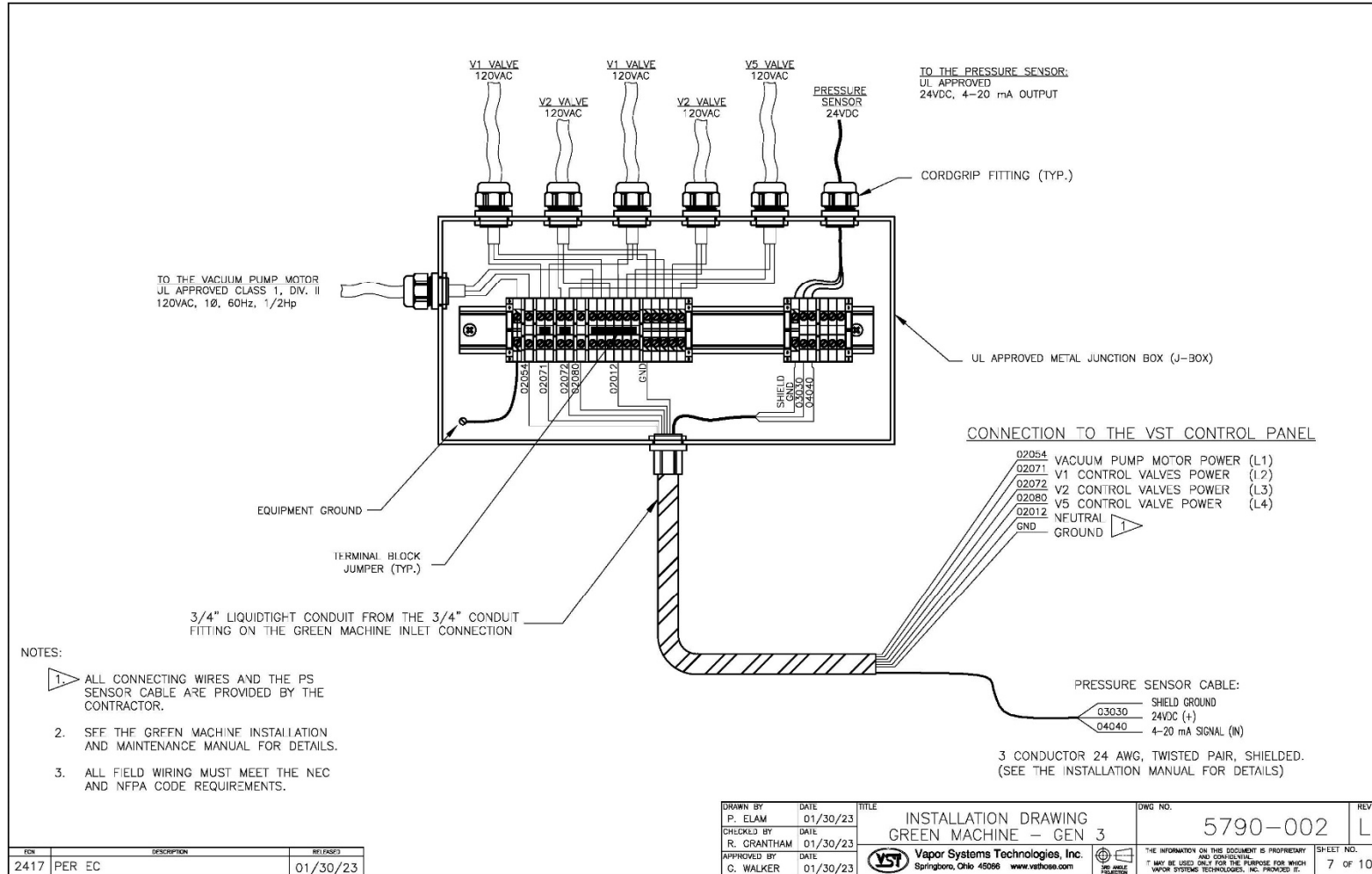

Figure 3-8: GREEN MACHINE Junction Box Field Wiring

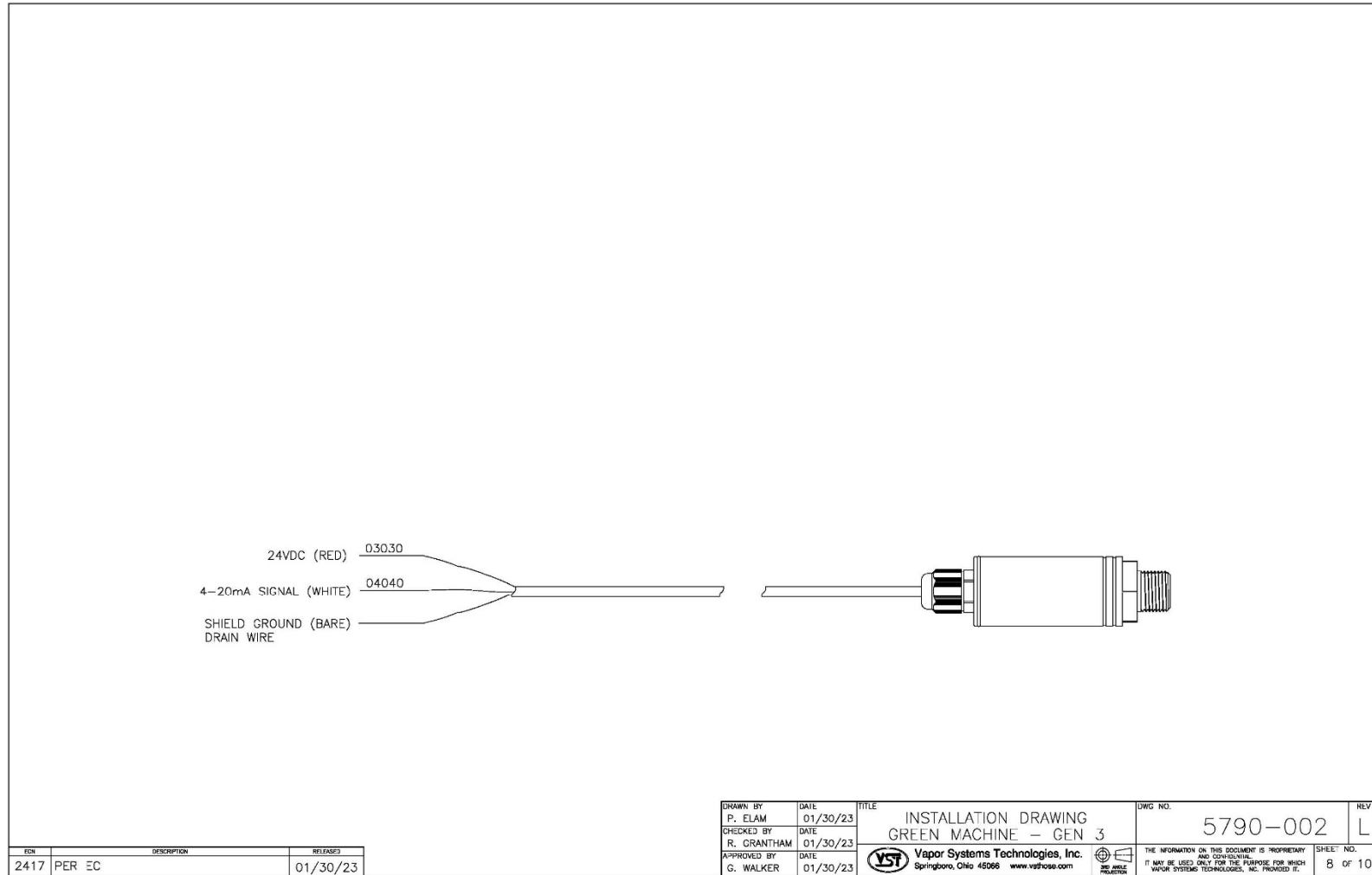

Figure 3-9: GREEN MACHINE Dispenser Shutdown Field Wiring

Chapter 4: Control Panel

4 VST Control Panel Overview

- The VST Control Panel is designed to manage the operations of the GREEN MACHINE based on UST vapor pressure. **Figure 4-1** shows the Main Screen with the following items:
 - **The VST Control Panel is what controls the GREEN MACHINE.**
 - The GREEN MACHINE will turn ON if the UST pressure is above 0.20 IWC.



Figure 4-1: Main Screen

4.1 Main Screen Overview

- The PLC will always power up in the Main Screen. **See Figure 4-1.**
- The GREEN MACHINE will always be in the Normal Operating mode when the Main Screen is showing on the PLC, unless there is an Alarm Condition.

Silence Button:

- When an alarm is active the buzzer on the front of the VST Control Panel will activate and the Silence Button will appear on the Main Screen.
- The Silence Button, when pushed, will start a 4-hour timer, which will interrupt the buzzer.
- After 4-hours, the buzzer will activate again so long as the alarm condition persists.

GM Status Bar:

- Normal (Green Bar) indicates the GREEN MACHINE is operating normally and may be in either RUNNING or IDLE mode.).

Date and Time:

- Push the Date and Time button to change the Date and Time.

Maintenance Screen and an Alarm Screen:

- Push the Maintenance Screen button to access the Maintenance Screen.
- A password (878) is required to access the Maintenance Screen.
- Push the Faults and Alarms button to access the Alarm Screen.

GREEN MACHINE Status Bar Messages:	
GREEN MACHINE – Running:	Due to the UST pressure being greater than 0.20 IWC
GREEN MACHINE – Idle:	Due to the UST pressure being less than 0.20 IWC
GREEN MACHINE – Alarm:	Go to the Alarm Screen to identify the Alarm: An Alarm has activated.
Displayed Data:	
UST Pressure (IWC):	Displays the UST pressure in real-time.
Run Cycles:	Displays the number of GREEN MACHINE completed cycles.
Date and Time	Date (MM/DD/YY) and 24-Hour Clock (HH:MM).

4.2 Maintenance Screen Overview



Figure 4-2: Maintenance Screen Overview

- The UST Pressure is displayed as Inches of Water (IWC).
- The Clear Press Alarm is used to clear any pressure alarm.
- The Clear Motor Alarm is used when the Vacuum Pump is in Alarm.
- The Run Tests button navigates to the Test Screen.
- The Startup Screen button navigates to the Startup Screen.
- Pushing the Home button stops all testing and returns to the Main Screen to the Normal Operating Mode.

4.3 Alarm Screen Overview



Figure 4-3: Alarm Screen

4.4 GREEN MACHINE Alarm Screen

The GREEN MACHINE Alarm Screen shows the following - See Figure 4-3 and 4-4:

A. Vacuum Pump Alarm

- When there is a problem with the vacuum pump, motor, or circuit
- The GREEN MACHINE will NOT operate during this Alarm.

B. Panel Power Alarm

- When the Disconnect Switch near the GREEN MACHINE is turned OFF or the station Emergency Shut-Off (ESO) has been activated.
- The GREEN MACHINE will NOT operate during this Alarm.

C. Overfill Alarm:

- Whenever there is a UST gasoline overfill at the station, the VST Control Panel is configured to alarm.
- If an Overfill Alarm activates while a test is running the test will terminate.
- The Alarm will display RED, OVERFILL ALARM.
- The GREEN MACHINE will NOT operate during this alarm.

D. Digital Storage Alarm Will Occur:

- If the card is not installed or installed incorrectly.
- After the card is installed, the Alarm will clear and show Normal (Green).
- The GREEN MACHINE will operate during this Alarm.

Pressure Alarms:**E. PRESSURE SENSOR ALARM**

- If at any time the Pressure Sensor does not provide readings.
- The Alarm Light turns ON and cannot be interrupted as long as the alarm condition persists.
- The GREEN MACHINE will not continue to operate.

F. 72-HR SHUTDOWN ALARM

- If any of the conditions above persist for more than 72 hours, the VST Control Panel alarm system will automatically suspend gasoline supply operation.
- The Alarm Light turns ON and cannot be interrupted as long as the alarm condition persists.
- The Alarm Buzzer will sound (can be reset every 4-hours) but cannot be disabled as long as the alarm condition persists.
- The GREEN MACHINE will continue to operate.
- The station will shut down after the 72-hours alarm timer expires



Figure 4-4: Alarm Screen with Active Alarm

Chapter 5: Data Collection

5 Data Collection

Run data of the GREEN MACHINE is stored on a USB drive inside the Control Panel. This data contains the following information and is updated every 15 seconds:

Data	Units
Date	MM/DD/YY
Time	HH:MM
UST Pressure	IWC
Run Mode	-
Alarm History	-
Motor Current Draw	Amps

5.1 USB Drive Collection Steps

- 1 Open the Control Panel door and locate the USB drive on the back of the screen. **See item 1 in Figure 5-1.**
- 2 Remove the USB drive and insert it into a computer.
- 3 Open the file directory for the USB drive and locate the .csv file within containing the raw data.

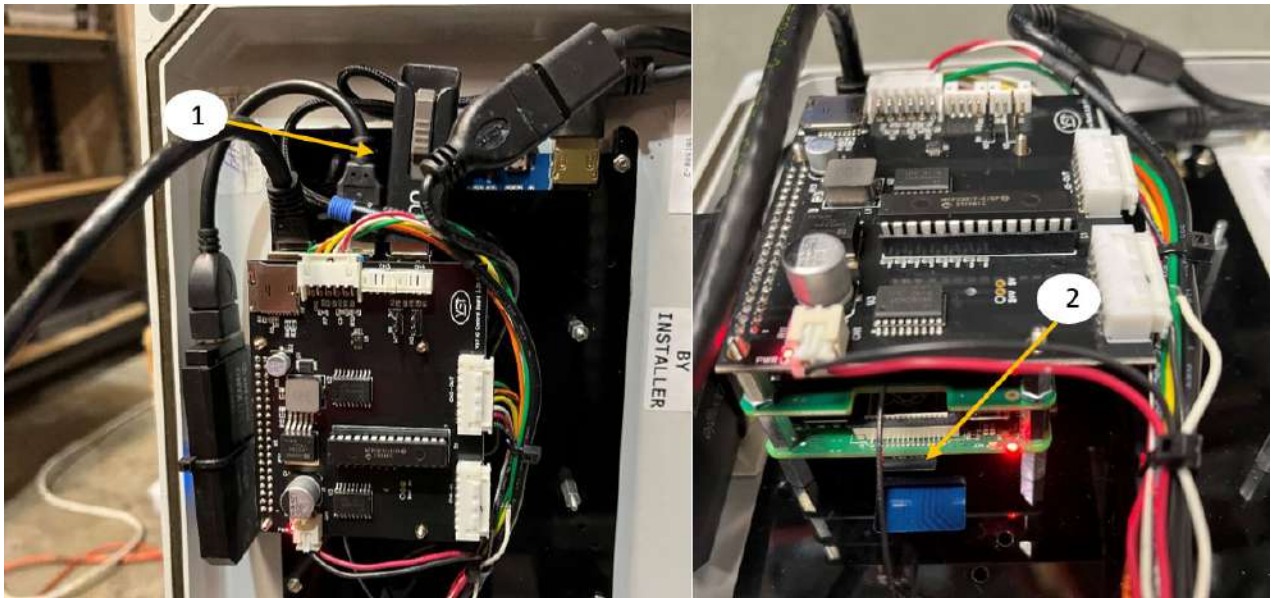

Figure 5-1: Primary and Secondary Data Storage Units

5.2 MicroSD Card Collection Steps

- 1 Open the Control Panel door and locate the SD card on the back of the screen.
See item 2 in Figure 5-1.
- 2 Remove the SD card and insert it into a computer.
- 3 Open the file directory for the SD card and locate the .csv file within containing the raw data.

5.3 Alarm numbers

Each alarm has a number assigned to it, the number shown on the data shows the active alarms by summing up those numbers. For example, 9 means that alarm 1 (Vacuum Pump Alarm) and alarm 8 (SD Card Alarm) are both active. The table below shows the numbers assigned to each alarm.

Alarm	Alarm Number
A – Vacuum Pump Alarm	1
B – Panel Power Alarm	2
C – Overfill Alarm	4
D – Digital Storage Alarm	8
E – Pressure Sensor Alarm	256

Left intentionally blank

Chapter 6: Testing & Start-Up

6 Post-Installation GREEN MACHINE Testing & Start Up

6.1 VST Control Panel Initial Start-Up Power:

When the power is turned ON to the VST Control Panel, the Main Screen will show on the PLC Screen with the label **GREEN MACHINE DISABLED: ENTER CODE**. See **Figure 6-1**. The Start-Up process can be completed with the GM DISABLED. The code to the VST Control Panel must be entered before the GREEN MACHINE can become operational. The code will be supplied to the Start-Up Contractor via e-mail after Appendix B is submitted online.



Figure 6-1: Main Screen with Disabled Message

6.2 Before beginning the Testing and Start-Up procedures

Follow the steps below to prepare the GREEN MACHINE and VST Control Panel for Testing & Start-Up

STEPS	DESCRIPTION
1.	Unscrew the 8 cover screws and remove the cover on the GREEN MACHINE.
2.	Close the three (3) ball valves between the GREEN MACHINE and the vent risers. Reference Figure 6-3.
3.	Remove the caps from the 3 tees. Reference Figure 6-3.
4.	Turn ON the GREEN MACHINE breaker at the Main Distribution Panel.
5.	At the PLC Main Screen, push the Maintenance Screen button to access the Password Screen. See Figure 6-1.
6.	Enter 878 at the Password Screen to access the Maintenance Screen. (The GREEN MACHINE will now be in the Manual OFF mode.)
7.	(The GREEN MACHINE cannot operate in the Automatic Mode when the Maintenance Screen is showing regardless of the UST pressure.)

6.3 Post Installation Start-Up Tests

During post-installation testing, the GREEN MACHINE will use outside air (no gasoline vapor from the USTs) to conduct these tests.

The following tests must be conducted in the order shown below to avoid damage to the equipment.

6.5	Functionality Test
6.6	Programming the Fuel Management System for the GREEN MACHINE Overfill Alarm Relay
6.7	Test the Overfill Alarm on the GREEN MACHINE VST Control Panel
6.8	Changing the Date and Time Procedure
6.9	Submitting Appendix B and Verification Code Retrieval

The final step in the installation process is to start up the GREEN MACHINE and get it field commission ready. This final commissioning process requires a Verification Code that will be entered into the PLC.

6.4 How to get a Verification Code:

STEPS	DESCRIPTION
1.	Go to https://vsthose.com/education-gm3-cs2a-mexico/
2.	Click on "Start-Up Contractor."
	Note: If you have not been trained to conduct Start-Up or Appendix B, Watch the training videos under "Start-Up Contractor", then go to Step 3.
3.	Click on "Appendix B - Start-Up Contractor Check-Out Form."
4.	Fill out Appendix B with the required photos then click on Submit.
5.	Receive an email from VST with the Verification Code and a copy of the filled-out Appendix B.

These items are to be checked in Appendix B as they are completed.

6.5 Functionality Test

6.5.1 The Purpose of the Functionality Test

The purpose of the Functionality Test is to verify that the Control Panel, Vacuum Pump, and the Control Valves are working properly.

6.5.2 Preparation for the Functionality Test

1. At the VST Control Panel, make sure the Maintenance Screen is showing on the PLC.
See Figure 6-2. (The GREEN MACHINE is now in the Manual OFF mode and will not operate.)
 - If the PLC is not in the Maintenance Screen: At the Main Screen, push the Maintenance Screen button to access the Password Screen, then enter the password to access the Maintenance Screen: The password is 878.
2. At the GREEN MACHINE, make sure the locks from the three ball valves have been removed, all three valves are closed, and the caps from the three tees have been removed.
See Figure 6-3.
3. Unscrew the 8 bolts and remove the cover from the GREEN MACHINE.



Figure 6-2: Maintenance Screen

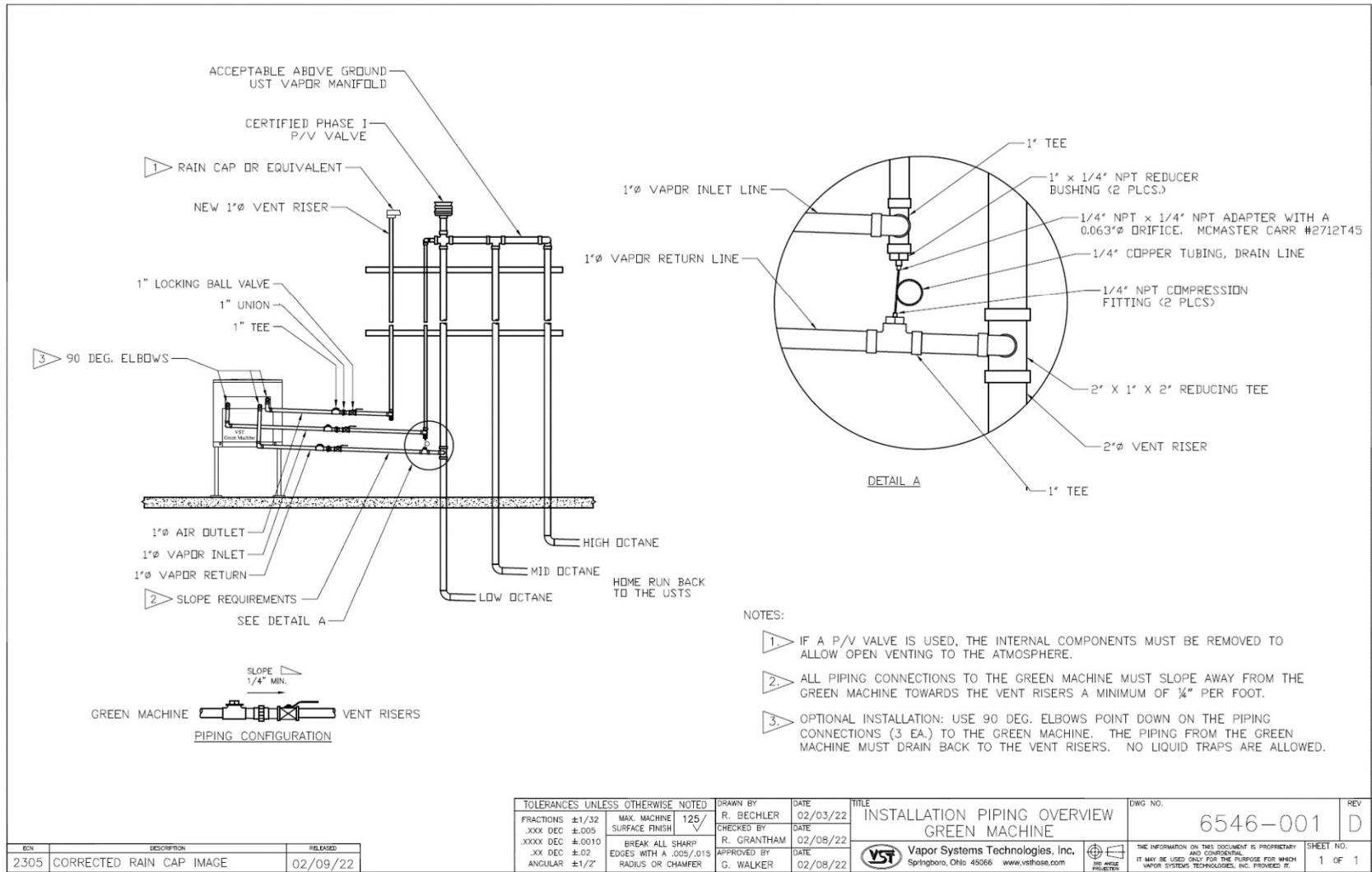

Figure 6-3: GREEN MACHINE Vapor Piping Layout

Functionality Test, continued...

10. During the Purge Cycle:

- 1) No air blowing/suction at the Vapor Inlet: NORMAL
- 2) No air blowing/suction at the Air Outlet: NORMAL
- 3) Momentary blowing at the Vapor Return: NORMAL
- 4) If these conditions are not found at the respective openings, check the following items:
 - Make sure the Vacuum Pump is not in alarm. If so, see Chapter 8: Troubleshooting.
 - Check the Control Valves to make sure they are all operational. See Chapter 8: Troubleshooting.
 - Make sure there is no debris in the valve seat. Clean the valves as shown in Chapter 7: Maintenance.
 - Make sure the flare nuts are tight. Check each 45° flare nut to make sure they are snug but not over tightened.

11. After the Functionality Test has ended:

- Lock open the three ball valves between the GREEN MACHINE and the Vent Risers, and replace the caps on the three tees.
- At the PLC, push the home button to return to the Main Screen.



Figure 6-4: Test Screen

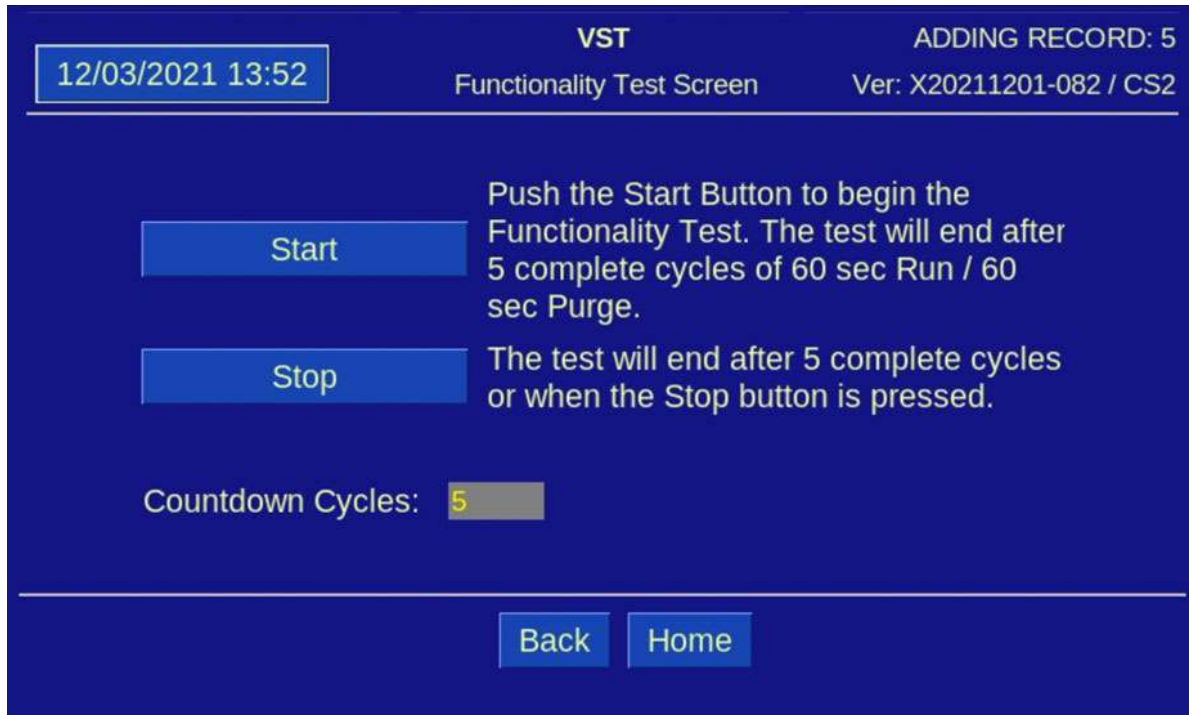

Figure 6-5: Functionality Test Screen

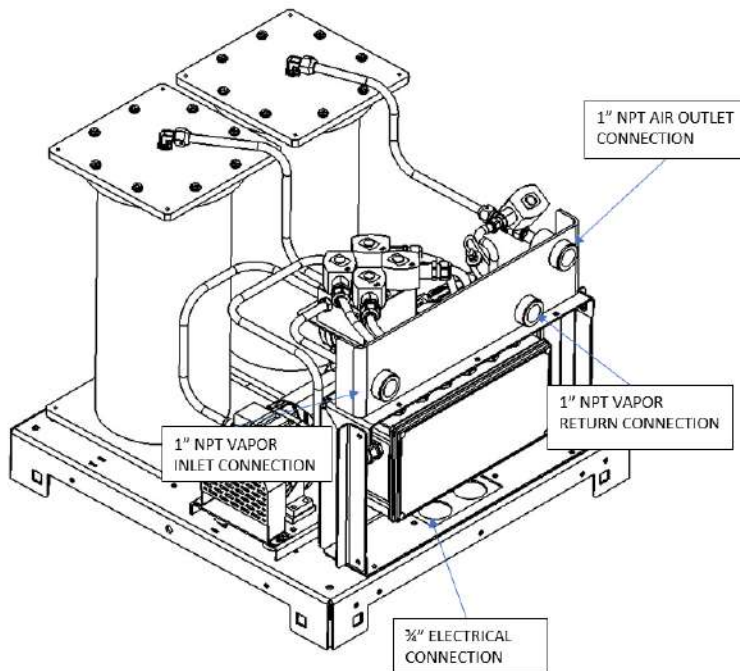

Figure 6-6: GREEN MACHINE Operation Diagram

6.6 Programming the Fuel Management System Overfill Alarm Relay for the GREEN MACHINE

OVERFILL ALARM RELAY CIRCUIT

- The Electrical Contractor has installed the Overfill Alarm signal wiring from the VST Control Panel to the "Fuel Management System Overfill Alarm" output module.
 - The VST Control Panel supplies 24 VDC to the Overfill Alarm relay.
 - The Overfill Alarm output "dry" relay (N.C.) shuts down the GREEN MACHINE when a UST reaches the Overfill Level (90%) during a fuel drop.
 - Label the Overfill relay "GM Overfill Alarm"
 - The wiring from the VST Control Panel to the Fuel Management System MUST be installed before the Start-Up of the GREEN MACHINE can be complete.
 - Reference Overfill terminal block wire numbers:
 - 24 VDC (+) – (Wire Number 03030)
 - 24 VDC (signal) – (Wire Number 05050)

6.7 Testing the Overfill Alarm on the GREEN MACHINE VST Control Panel

- Test the output relay that was programmed in the previous step.
- The VST Control Panel will show an Overfill Alarm, and this alarm will persist until 2 hours after the alarm condition (in this case the test) ends.
- To manually override the Overfill Alarm once the test is complete, navigate to the Startup Screen. **See Figure 6-9.**
- The Startup Screen can be accessed from the Maintenance Screen by pushing the Startup Screen Button and entering the password “1793”.
- On the Startup Screen, press the Overfill Override Button.

6.8 Changing the Date and Time Procedure



Figure 6-7: Main Screen

1. From the Main Screen, push the Date and Time button. This will bring up the Date and Time Interface Screen. **See Figure 6-7.**
2. On the Date and Time Interface Screen, insert the Date: (MM/DD/YY) then the Time: (HH:MM). **See Figure 6-8.**
3. After the Date and/or Time has been set, push Enter to accept the change(s) and return to the Main Screen.
4. After returning to the Main Screen, check to see if the Date and Time are correct.



Figure 6-8: Date and Time Screen

6.9 Submitting Appendix B to VST for the Verification Code

6.9.1 Start Up of the GREEN MACHINE

1. Go to <https://vsthose.com/education-gm3-cs2a-mexico/>
2. Click on “Start-Up Contractor.”
Note: If you have not been trained to conduct Start-Up or Appendix B, watch the videos under “Start-Up Contractor” then go to Step 3.
3. Click on “Appendix B - Start-Up Contractor Check Out Form.”
4. Fill out and submit Appendix B with the required photos.
5. Receive an email from VST with the Verification Code and a copy of the filled-out Appendix B.

6.9.2 Procedures

1. Apply power to the VST Control Panel
The PLC starts up in the Main Screen where the GREEN MACHINE is shown to be DISABLED.
See **Figure 6-1**.
2. Push the Maintenance button, then enter 878 on the Password Screen to go to the Maintenance Screen.
3. Using Chapter 6: Testing and Start-Up, complete the following sections:
Chapter 6 Sections for Reference:

Section	Title
6.5	Conduct the Functionality Test
6.6	Programming the Fuel Management System Overfill Relay for the GM Overfill Alarm
6.7	Conduct the Overfill Alarm Test
6.8	Change the Date/Time per the time-zone
6.9	How to submit Appendix B to VST to obtain the Verification Code
4. Complete Appendix B Checklist Form, then push the SUBMIT button.
(All the fields contained in Appendix B MUST BE CHECKED OR FILLED OUT, INCLUDING PICTURES.)
5. An email with the Verification Code is sent to the person conducting the Start-Up after Appendix B is SUBMITTED to VST.
6. On the Maintenance Screen, push the “Startup” button to navigate to the Startup Screen. The password for this screen in “1793”. See **Figure 6-2**.
7. Push the “Startup Code” button. See **Figure 6-9**.
8. At the Verification Code Screen, enter the Code that was received in the email, then push ENTER.
See **Figure 6-10**.
9. If the correct Code was entered, the PLC will show the Main Screen and the GREEN MACHINE will now be operational.
10. If the incorrect Code is entered, the Verification Code Screen will be blank again.
11. Once the correct Verification Code is entered, the PLC returns to the Main Screen and the GREEN MACHINE is now fully operational.
12. At the Main Screen, the GREEN MACHINE will turn ON if the UST pressure is at or above 0.20 IWC, or remain OFF if the UST pressure is below 0.20 IWC.
13. The GREEN MACHINE:
 - Is Operational
 - Start-Up is complete and verified
 - The Overfill protection is installed and tested



Figure 6-9: Startup Screen



Figure 6-10: Startup Password Screen

Chapter 7: Maintenance Procedures

7 Maintenance Overview

- VST recommends conducting Maintenance on the GREEN MACHINE annually to make sure all the components are in good working order. If the annual maintenance is not conducted, there is a possibility the GREEN MACHINE may not be operating properly.
- The Vacuum Pump, Motor, and Control Valves are the only components with moving parts in the GREEN MACHINE; therefore, it requires very little maintenance.
- All replacement parts must be from VST's recommended replacement parts list located in Chapter 9: Replacement Procedures Section.
- If the GREEN MACHINE is not functioning properly consult Chapter 8: Troubleshooting Section to determine which component may need to be repaired or replaced.

7.1 Maintenance Procedures

1. At the VST Control Panel Main Screen, check to make sure there are no alarms. **See Figure 7-1.**
If there are alarms, repair the item causing the alarm (See Chapter 8: Troubleshooting) before proceeding.
2. VST has recommended spare parts that might be needed when conducting Maintenance. **See Section 7-2.**
3. Conduct a Functionality Test: **See Section 7-3.**
The Functionality Test will verify the GREEN MACHINE is operating properly.
 - If the Functionality Test Passes, go to Step 4.
 - If the Functionality Test does not Pass (See Chapter 8: Troubleshooting Procedures)
4. The Pressure Sensor Verification Test Procedure: **See Section 7-4.**
 - This procedure will verify that the Pressure Sensor is operating properly and within specifications.
5. Rubber Flange Sleeve Replacement Procedure: **See Section 7-5.**
To keep the GREEN MACHINE operational, replace the rubber flange sleeve yearly.
6. Cleaning the Control Valves: **See Section 7-6.**
Cleaning the control valves will reduce valve noise. Check the valve components for wear and damage and keep the valves operational for a longer period of time.
7. Check the Air Outlet for Liquid Condensate: **See Section 7-7.**
Check annually for liquid condensate in the air outlet pipe.
8. Check the vacuum pump performance: **See Section 7-8.**



Figure 7-1: VST PLC Main Screen w/no Alarms

7.2 Recommended Replacement Parts

VST recommends the ASC bring the parts shown in the table below for replacement parts. The entire list of GREEN MACHINE replacement parts can be found in Chapter 9: Replacement Procedures.

See Figure 7-2.

Ref. #	Description	Part No.	Quantity	Manuf.
1	VACUUM PUMP MOTOR (ONLY), (not shown)	GM-027	1	VST
2	MODEL 2 VACUUM PUMP (ONLY)	GM-042	1	
3	RUBBER FLANGE SLEEVE (not shown)	GM-004	1	
4	CONTROL VALVES – CORE REBUILD KIT	GM-006	5	
5	PRESSURE SENSOR	GM-067	1	

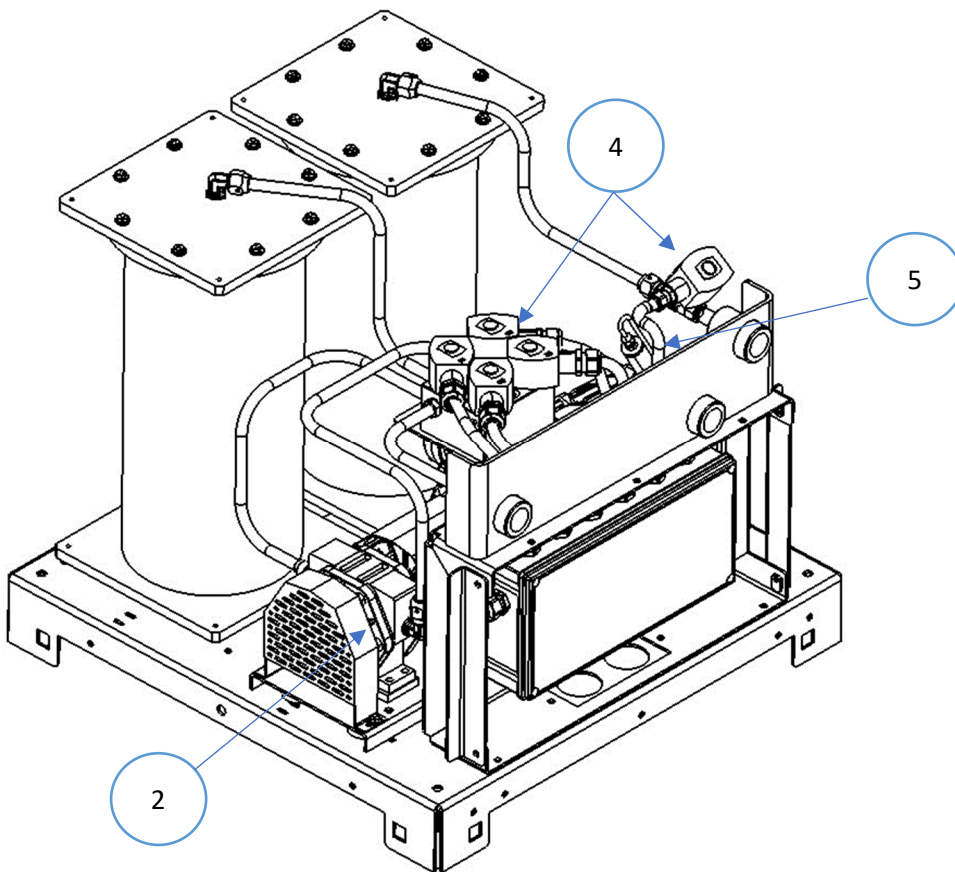

Figure 7-2: Maintenance Replacement Parts

7.3 Functionality Test

7.3.1 The Purpose of the Functionality Test

The purpose of the Functionality Test is to verify that the Control Panel, Vacuum Pump, and the Control Valves are working properly.

7.3.2 Preparation for the Functionality Test

1. At the VST Control Panel, make sure the Maintenance Screen is showing on the PLC. **See Figure 7-3.** (The GREEN MACHINE is now in the Manual OFF mode and will not operate.)

If the PLC is not in the Maintenance Screen: At the Main Screen, push the Maintenance Screen button to access the Password Screen, then enter the password to access the Maintenance Screen: The password is 878.

2. At the GREEN MACHINE, make sure the locks from the three ball valves have been removed, all three valves are closed, and the caps from the three tees have been removed. **See Figure 7-4.**
3. Unscrew the 8 bolts and remove the cover from the GREEN MACHINE.



Figure 7-3: Maintenance Screen

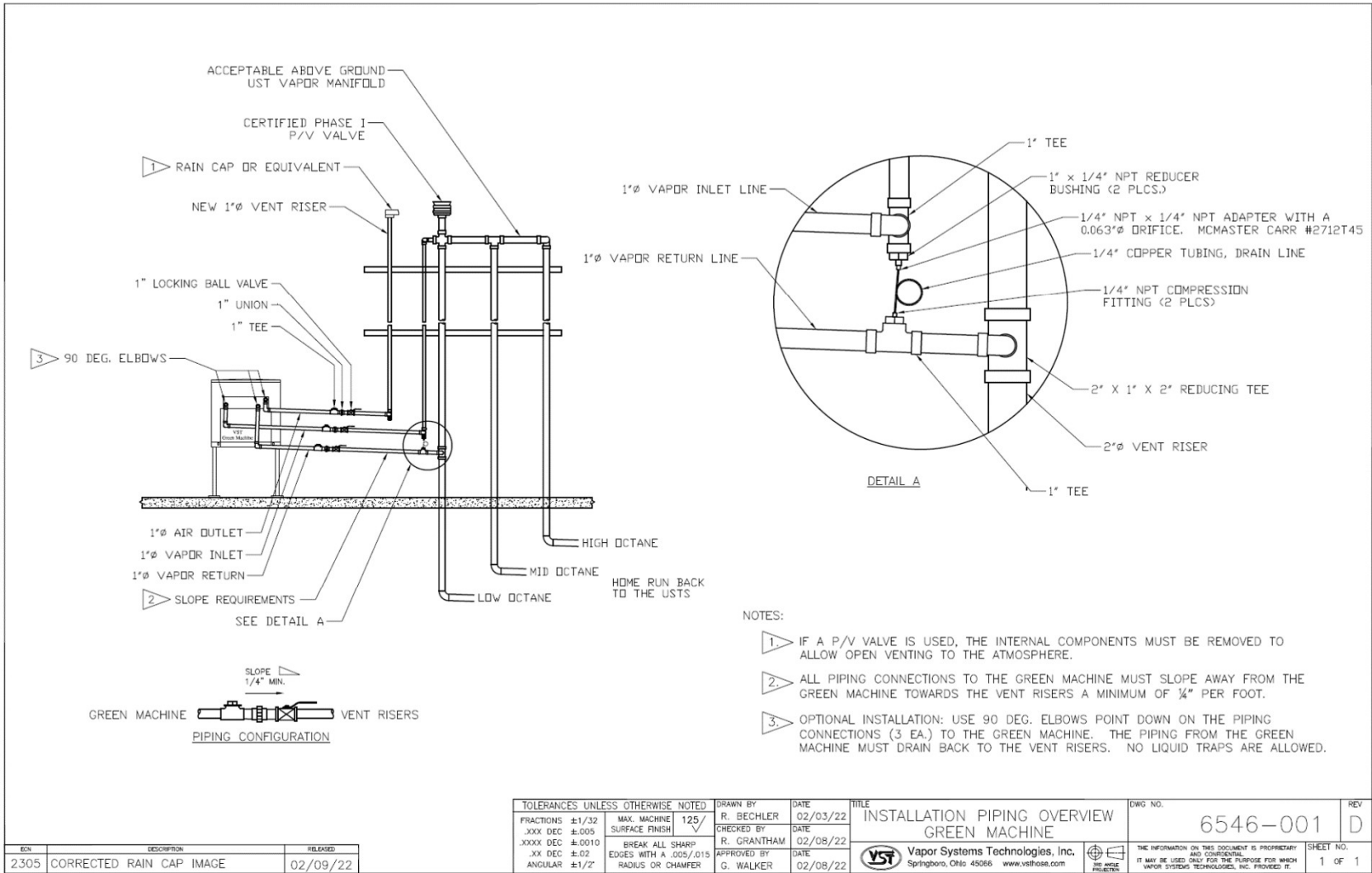

Figure 7-4: GREEN MACHINE Vapor Piping Layout

7.3.3 Functionality Test Procedures

1. Press the "Run Tests" button on the Maintenance Screen. **See Figure 7-3.**
2. Select the Functionality Test from the menu. **See Figure 7-5.**
3. To start the Functionality Test, push the Start Button. **See Figure 7-6.**
4. The GREEN MACHINE will run for 60-seconds then purge for 60-seconds (this is one cycle).
5. The GREEN MACHINE will continue to cycle 5 times or until the "stop" is pushed to end the test.
 - There are 5 cycles to provide enough time to conduct the test.
 - The back button or home button can also be pressed to end the test.
6. When the test has ended, the PLC will display GREEN MACHINE OFF.
7. During the 60-second Run Cycle: **See Figure 7-7.**
 - Place your hand over the tee opening at the Vapor Inlet and feel for suction.
 - Next, place your hand over the tee opening at the Vapor Return and feel for zero airflow.
 - Next, place your hand over the tee opening at the Air Outlet and feel for air blowing.
8. During the Run Cycle:
 - 1) Suction at the Vapor inlet: NORMAL
 - 2) Air blowing out the Air Outlet: NORMAL
 - 3) No air blowing/suction at the Vapor Return: NORMAL
 - 4) If these conditions are not found at the respective openings, check the following items:
 - Make sure the Vacuum Pump is not in alarm. If so, see Chapter 8: Troubleshooting.
 - Check the Control Valves to make sure they are all operational. See Chapter 8: Troubleshooting.
 - Make sure there is no debris in the valve seat. Clean the valves as shown in Section 7.6: Cleaning the Control Valves.
 - Make sure the flare nuts are tight. Check each 45° flare nut to make sure they are snug but not over tightened.
9. During the 60-second Purge Cycle: **See Figure 7-7.**
 - After the Purge Cycle has begun, place your hand over the tee opening at the Vapor Return and feel for air blowing. The blowing air will reduce to zero flow soon after the Purge Cycle begins.
 - Next, place your hand over the tee opening at the Vapor Inlet and feel for zero airflow.
 - Next, place your hand over the tee opening at the Air Outlet and feel for zero airflow.

Functionality Test, continued...

10. During the Purge Cycle:

- 1) No air blowing/suction at the Vapor Inlet: NORMAL
- 2) No air blowing/suction at the Air Outlet: NORMAL
- 3) Momentary blowing at the Vapor Return: NORMAL
- 4) If these conditions are not found at the respective openings, check the following items:
 - Make sure the Vacuum Pump is not in alarm. If so, see Chapter 8: Troubleshooting.
 - Check the Control Valves to make sure they are all operational. See Chapter 8: Troubleshooting.
 - Make sure there is no debris in the valve seat. Clean the valves as shown in Section 7.6: Cleaning the Control Valves.
 - Make sure the flare nuts are tight. Check each 45° flare nut to make sure they are snug but not over tightened.

11. After the Functionality Test has ended:

- Lock open the three ball valves between the GREEN MACHINE and the Vent Risers, and replace the caps on the three tees.
- At the PLC, push the home button to return to the Main Screen.



Figure 7-5: Test Screen

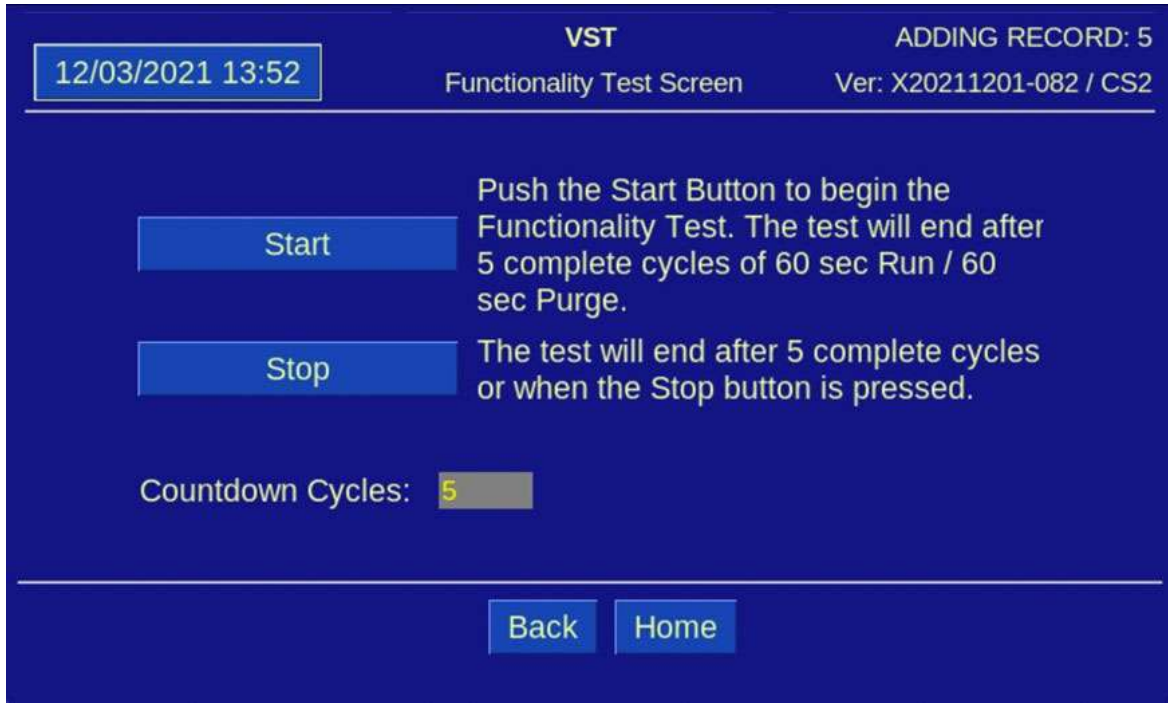

Figure 7-6: Functionality Test Screen

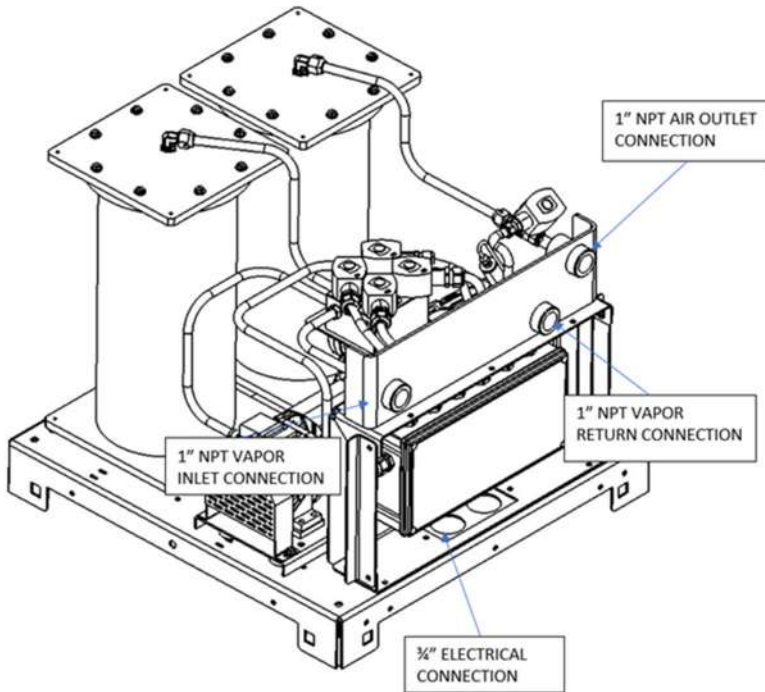

Figure 7-7: GREEN MACHINE Operation Diagram

7.4 Pressure Sensor Verification Test

This procedure was written to verify the Pressure Sensor is operating properly and within specifications: The Pressure Sensor reading on the VST Control Panel PLC Main Screen is checked against atmospheric pressure at the Pressure Sensor.

7.4.1 Safety:



Use lockout-tagout procedures prior to starting work.

7.4.2 Procedure:

1. Enter the Maintenance screen using the code 878 to disable the GREEN MACHINE.
 - This will allow 24 VDC power to the PLC and the Pressure Sensor but will disconnect 120 VAC power to the GREEN MACHINE. Power to the PLC and Pressure Sensor will remain ON.
2. Follow lockout & tagout procedures prior to starting work.
3. Close the ball valve at vapor return line. Then remove the plug on the tee.
4. Wait at least 2-minutes for the pressure to equalize before reading the pressure on the PLC Main Screen.
5. At the VST Control Panel PLC Main Screen, make sure the Pressure reading is 0.0 +/- 0.10 IWC. **See Figure 7-1.**

The Pressure Sensor Specification at atmospheric Pressure is 0.0 +/- 0.10 IWC.

 - If the pressure reading is within specifications, the Pressure Sensor is reading correctly.
 - If the pressure reading is outside the specification, replace the Pressure Sensor. In the IOMT Manual, See Chapter 9 for replacement procedures.
6. After testing is complete: plug the tee and open the ball valve that was closed.
7. Return to the Home screen at the VST Control Panel. The GREEN MACHINE is now operational and will operate if the UST pressure is greater than or equal to 0.20 IWC.
8. Check the VST Control Panel to make sure the Main Screen is showing and there are no alarms.

7.5 Rubber Flange Sleeve Replacement

Safety



Use lockout / tagout procedures prior to starting work.

VST recommends replacing the Rubber Flange Sleeve every time Maintenance is performed on the GREEN MACHINE even if the Rubber Flange Sleeve does not look damaged or worn.

NOTE: The Rubber Flange Sleeve replacement is done with the vacuum pump motor assembly still attached to the GREEN MACHINE base.

7.5.1 Removing the Rubber Flange Sleeve

See Figure 7-8.

1. Turn off the GREEN MACHINE breaker in the main electrical distribution panel.
2. Follow lockout & tagout procedures prior to starting work.
3. Unscrew the 8 cover screws and remove the cover from the GREEN MACHINE.
4. Remove the two tubes attached to the pump.



Figure 7-8: Two tubes removed from vacuum pump

5. Remove the side fan guard.

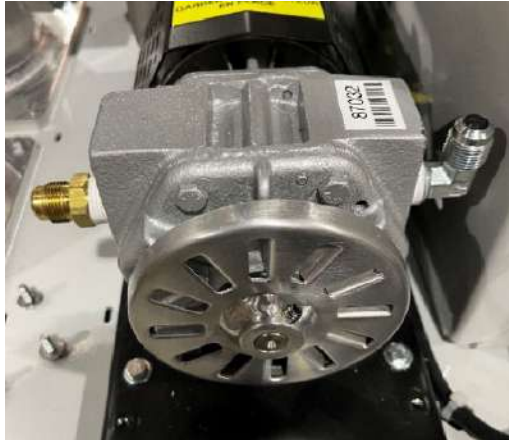

Figure 7-9: Side Fan Guard Removed

6. Remove the 4 vacuum pump mounting bolts. Keep the shims and 4 bolts for reuse.



Figure 7-10: Vacuum Pump Mounting Bolts

7. Slide the pump away from the motor so the rubber flange sleeve can be removed.

7.5.2 Replacing the Rubber Flange Sleeve

1. Insert a new rubber flange sleeve and slide the pump back to its original position.
 - Make sure the motor-side drive coupling is snug (not tight) against the rubber flange sleeve.
2. Replace any shims that moved while moving the pump.
3. Re-install and tighten the 4 pump mounting bolts to the base plate. Make sure the Motor Shaft and Vacuum Pump shafts are in alignment.
4. Re-install the fan guard over the coupling flanges, and the side fan guard.
5. Put the cover on the GREEN MACHINE and screw on the 8 cover screws.
6. Remove the lock(s) and tags from the lockout & tagout.
7. After the work is completed, return to the Main Screen on the VST Control Panel. The GREEN MACHINE is now operational.

7.6 Cleaning the Control Valves

Safety



Use lockout / tagout procedures prior to starting work.

7.6.1 Removing the Valve Solenoid and Core Assembly

1. Turn off the GREEN MACHINE breaker in the main electrical distribution panel.
2. Follow lockout & tagout procedures prior to starting work.
3. Unscrew the 8 cover screws and remove the cover from the GREEN MACHINE.
4. Unlock and close the three ball valves between the GREEN MACHINE and the vent risers.

See Figure 7-11.

5. Remove the retaining clip from the solenoid that is not working.
6. Remove the nameplate by pushing the solenoid down towards the valve body, then lift and slide the nameplate off.
7. Slide the solenoid off the solenoid base. **DO NOT** lose the spring washer located below the solenoid on the solenoid base.
8. Using a 1" wrench, remove the solenoid base from the valve body, the core assembly with core spring, and the body gasket.
9. Inspect and clean the following parts with a rag and carburetor cleaner or an equivalent cleaning solution: **Be sure to use eyes and hands protection.**
10. Check to make sure the copper ring in the bottom of the solenoid base is not missing or broken into pieces. **See Figure 7-12.**
11. Clean the core assembly, including the metal plunger, the spring, and the rubber seal.
12. Check the rubber seal on the bottom of the core assembly for distortion. Distortion would indicate an indentation into the rubber from the valve seat.
13. Check to see if the spring is cracked or broken.
14. Inspect the body gasket in the valve base for damage and wear.
15. If there is any damage, broken parts, or excessive wear on any part of a control valves assembly, VST recommends that all five control valves be replaced.

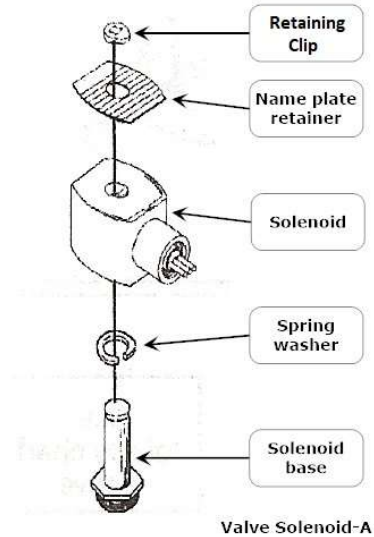

Figure 7-11: Valve Solenoid Assembly



Figure 7-12: Solenoid Base Interior

7.6.2 Replacing the Valve Solenoid and Core Assembly

See Figure 7-13.

1. Install the clean Core Assembly which includes:
 - Solenoid base
 - Core assembly with core spring
 - Body gasket
2. Screw the solenoid base and tighten with a 1" wrench until tight. Make sure to install the body gasket with the solenoid base.
3. Place the spring washer on the solenoid base, then slide the solenoid on to the solenoid base.
4. Slide and lock the nameplate on the solenoid.
5. Snap the retaining clip on the solenoid base.
6. Open the three ball valves between the GREEN MACHINE and the vent risers and lock in the OPEN position.

CAUTION: THREE BALL VALVES BETWEEN THE GREEN MACHINE AND THE VENT RISERS MUST BE OPEN BEFORE APPLYING POWER TO THE VST CONTROL PANEL TO AVOID DAMAGE TO THE GREEN MACHINE INTERNAL EQUIPMENT.

7. Put the cover on the GREEN MACHINE and screw on the 8 cover screws.
8. Remove the lock(s) and tags from the lockout & tagout.
9. After the work is completed, return to the main screen on the VST Control Panel. The GREEN MACHINE is now operational.

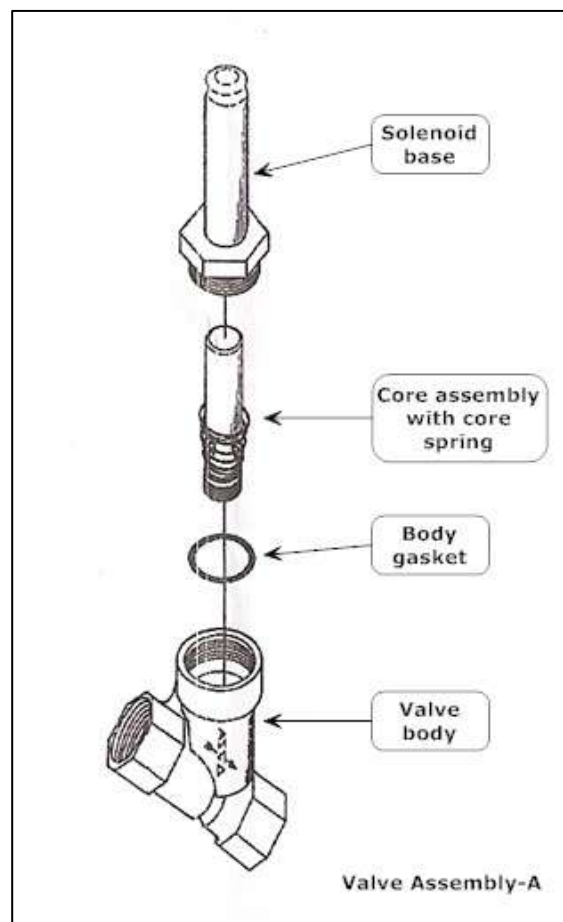

Figure 7-13: Valve Core Assembly

7.7 Check the Air Outlet for Liquid Condensation

7.7.1 Safety



Use lockout / tagout procedures prior to starting work.

7.7.2 Removing the Drain Plug

See Figure 7-14.

1. Turn off the GREEN MACHINE breaker in the main electrical distribution panel.
2. Follow lockout & tagout procedures prior to starting work.
3. Place a container below the drain tee at the bottom of the Air Outlet vent riser.
4. Slowly remove the drain plug from the bottom of the Air Outlet vent riser to see if any liquid drains from the line.
5. Keep the drain plug for re-use.

7.7.3 Replacing the Drain Plug

See Figure 7-14.

1. After all the liquid has drained (if any), put non-hardening pipe-joint compound on the plug threads.
2. Re-install the plug into the drain tee and tighten.
3. Remove the lock(s) and tags from the lockout & tagout.
4. After the work is completed, return to the main screen on the VST Control Panel. The GREEN MACHINE is now operational.

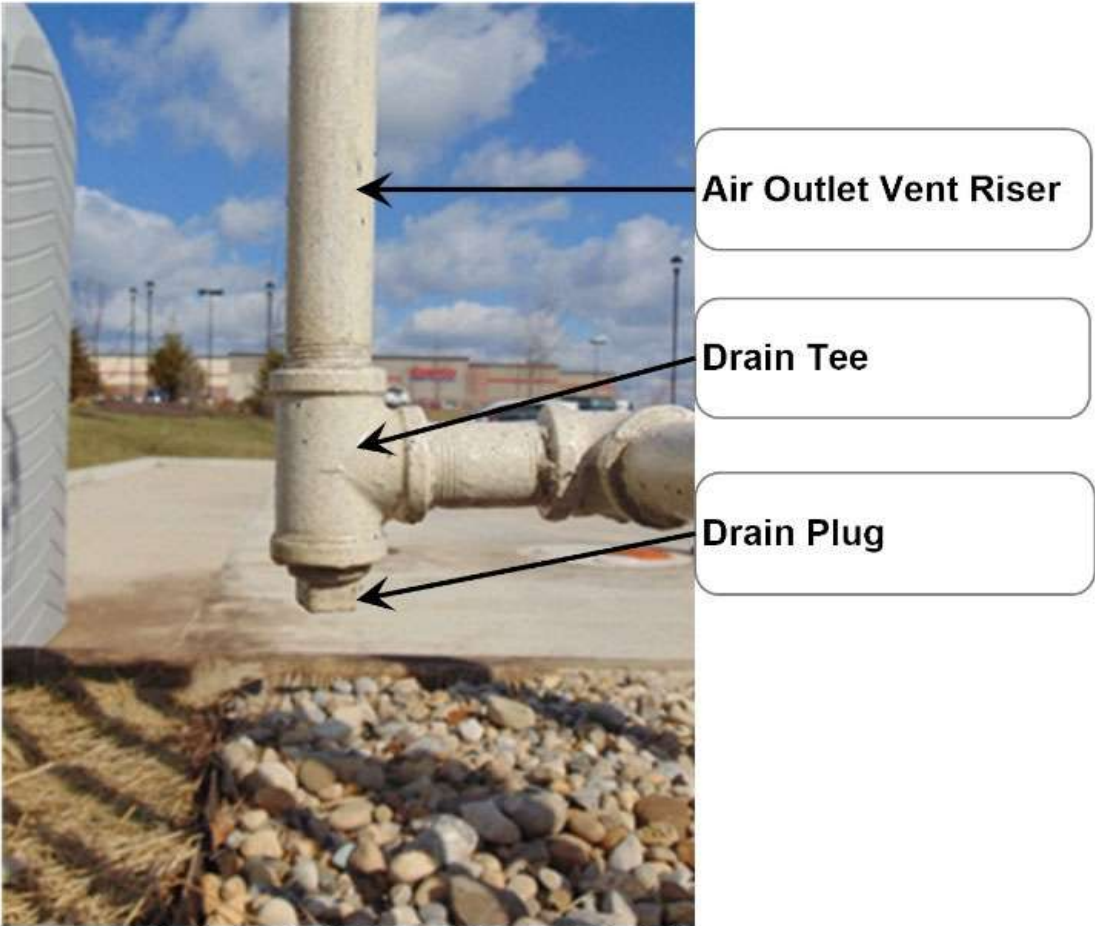

Air Outlet Drain Tee and Plug, 3-16-2017

Figure 7-14: Air Outlet, Drain Tee, and Plug

7.8 Vacuum Pump Performance Test

7.8.1 Testing the Vacuum Level of the GREEN MACHINE Vacuum Pump

1. At the VST Control Panel, press the Maintenance button to navigate to the Maintenance Screen. The password is 878. The GREEN MACHINE is now OFF and will not operate.
2. Close the lockable ball valve on the vapor inlet pipe between the GREEN MACHINE and the vent risers.
3. Remove the plug from the tee on the vapor inlet pipe between the GREEN MACHINE and the vent risers.
4. Install a 1" NPT Male x ¼" NPT Female adapter and vacuum gauge on the tee. Use PTFE tape on the gauge and adapter threads. There should be no way for air to enter the vapor inlet port of the GREEN MACHINE.
 - a. VST recommends the Grainger item # 4FLT5 (30-0 in Hg) for a vacuum gauge, or an equivalent.
5. On the Maintenance Screen, press the Manual ON button. This will run the GREEN MACHINE in manual mode until the Manual OFF button is pushed or the cycle completes.
6. At the GREEN MACHINE, during the first 2.5 minutes from pushing the Manual ON button, record the maximum vacuum level achieved by the GREEN MACHINE on the vacuum gauge. The minimum acceptable vacuum level for a given altitude is on **Table 3**. Find the altitude of the site being tested and compare the measured vacuum level with the minimum acceptable vacuum level on the table.
 - a. If the tested vacuum level does not exceed the minimum, the vacuum pump must be replaced.
 - b. If the tested vacuum level exceeds the minimum, the step is complete.
7. At the VST Control Panel, press the Manual OFF button to turn OFF the GREEN MACHINE.
8. Remove the vacuum gauge and 1" x ¼" adapter from the vapor inlet pipe.

Altitude Above Sea Level (feet)	Altitude Above Sea Level (meters)	Minimum Vacuum Level (inHg)
0	0	23.9
1000	305	23.1
2000	610	22.2
3000	914	21.4
4000	1219	20.6
5000	1524	19.9
6000	1829	19.2
7000	2134	18.5
8000	2438	17.8
9000	2743	17.1
10000	3048	16.5

Table 3: Minimum Vacuum Level by Altitude

7.9 Testing the Flowrate of the GREEN MACHINE Vacuum Pump

1. At the same tee on the vapor inlet pipe, install a 1" NPT Male x ½ "NPT Female adapter flowmeter to measure the flow of air into the vapor inlet tee. Two ½" x ½" tubing adapters and ½" dia. tubing are needed. Use PTFE tape on the flowmeter and adapter threads.
 - a. VST Recommends a flow meter with a max of 10 scfm, ½" tubing connections, and 0.25 scfm graduation scale.
2. Once again, press the Manual ON button to begin a cycle.
3. At the GREEN MACHINE, record the maximum flow through the flowmeter. The flow should be at least 4 CFM.
 - a. If the flow is less than 4 CFM, the vacuum pump must be replaced.
 - b. If the flow is greater than 4 CFM, the step is complete.
4. At the VST Control Panel, press the Manual OFF button to turn OFF the GREEN MACHINE.
5. At the GREEN MACHINE, remove the flowmeter and adapter, and reinstall the plug in the vapor inlet pipe between the GREEN MACHINE and the vent risers. Use PTFE tape on the plug threads.
6. Return the GREEN MACHINE to the Main Screen by pressing the ESC button.
7. Open the lockable ball valve on the vapor inlet pipe between the GREEN MACHINE and the vent risers.

This page left intentionally blank

Chapter 8: Troubleshooting

8 Troubleshooting Procedures

8.1 Troubleshooting Procedures Overview

- The purpose of the Troubleshooting chapter is to explain what troubleshooting actions to take when the GREEN MACHINE or the VST Control Panel are not functioning properly.
- In detail, this guide will cover:
 - 8.2 Alarm Overview
 - 8.3 Troubleshooting Procedures
- Replacement parts procedures are found in Chapter 9.

8.1.1 Troubleshooting the GREEN MACHINE and the VST Control Panel

- Included in this manual are the troubleshooting procedures for the following items:
 - 8.4 Panel Power Alarm
 - 8.5 Pressure Sensor Alarm
 - 8.6 Vacuum Pump Alarm
 - 8.7 Overfill Alarm
 - 8.8 Data Storage Alarm



Figure 8-1: VST GREEN MACHINE Control Panel Main Screen

8.2 Alarm Overview

- The VST Control Panel is continuously monitoring the VST GREEN MACHINE for alarm conditions.
 - During normal operation when the GREEN MACHINE is functioning properly and no alarm conditions exist, the GM Status Bar will be green. **See Figure 8-1.**
 - When the system is in alarm, the GM Status Bar will turn red. **See Figure 8-2.**
- If an Alarm occurs, the Alarm Screen will show what is in the alarm condition. **See Figure 8-3.**
 - If more than one alarm condition exists, the display will show all the alarm conditions and the appropriate messages.
 - The system automatically posts an alarm to data storage showing the alarm type, date and time the alarm condition occurred.
- No power to the Control Panel does not generate an alarm.

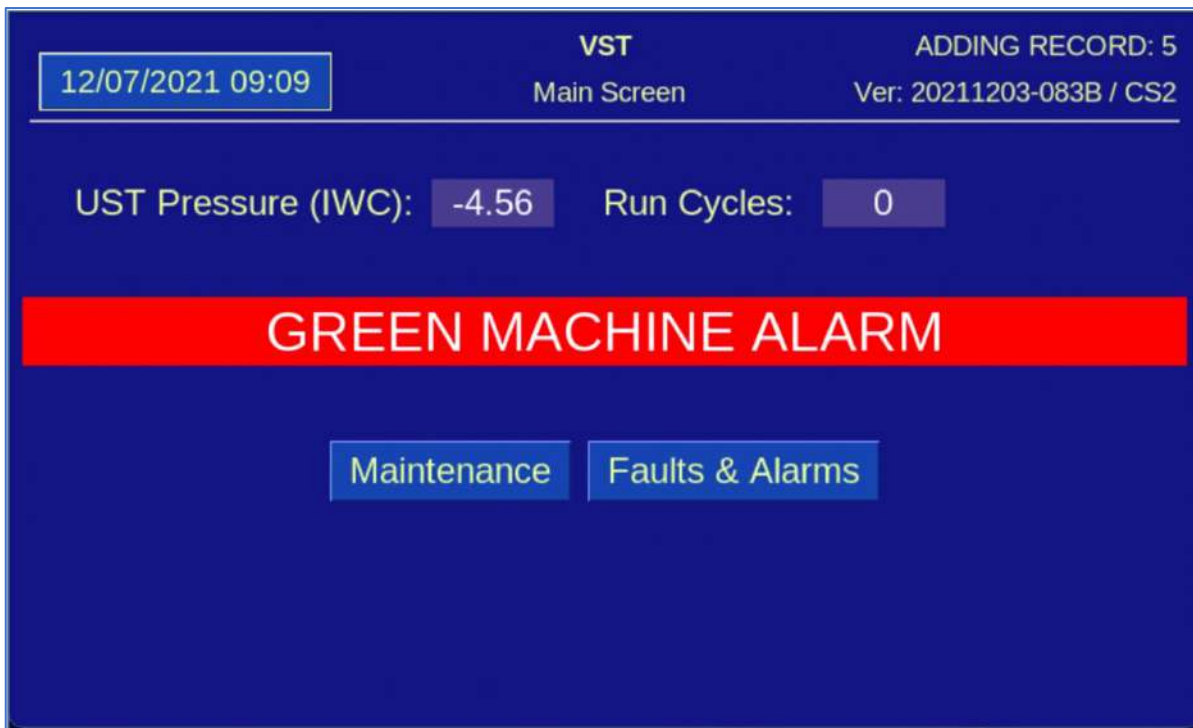

Figure 8-2: VST GREEN MACHINE Control Panel Main Screen with an Alarm Active

8.2.1 Alarm List

- A. Vacuum Pump Alarm
- B. Panel Power Alarm
- C. Overfill Alarm
- D. Data Storage Alarm
- I. Pressure Sensor Alarm



Figure 8-3: VST Control Panel Alarms and Faults Screen Example

8.3 Troubleshooting Procedures

- Each of the following Troubleshooting Procedures is preceded by a Decision Tree.
 - The tree itself is a high-level overview of the required steps.
 - Each step is explained in greater detail immediately following the Decision Tree.
- If there are any questions or concerns while performing these Troubleshooting Procedures, contact VST at 937-704-9333.

8.4 Power to the VST Control Panel or PLC Controller is OFF

8.4.1 Control Panel General Information

- The VST Control Panels are pre-wired and tested prior to leaving the factory.
- Check all wiring connections to make sure they are properly connected.
 - **Figure 8-4:** Panel is powered from the ESO circuit directly, and wires are run from the Safety Switch IN and Safety Switch OUT terminals to a Safety Disconnect Switch near the GREEN MACHINE.
- The VST Control Panel is MET Listed to comply with UL Standard 508A, and CSA C22.2 No.14.
- If an electrical component has malfunctioned inside the VST Control Panel, all the electrical components MUST BE ordered from the Replacement Parts List (Chapter 9) in this manual.

8.4.2 Panel Power Alarm: Troubleshooting Steps

Steps	Procedures
<ol style="list-style-type: none">1. Check that the breaker is ON at the main electrical distribution panel2. Check that the station Emergency Shutoff (ESO) is not active3. Check that the Safety Disconnect Switch is powered ON at the GREEN MACHINE area4. If all the above steps are true and the panel still does not have power, call VST	

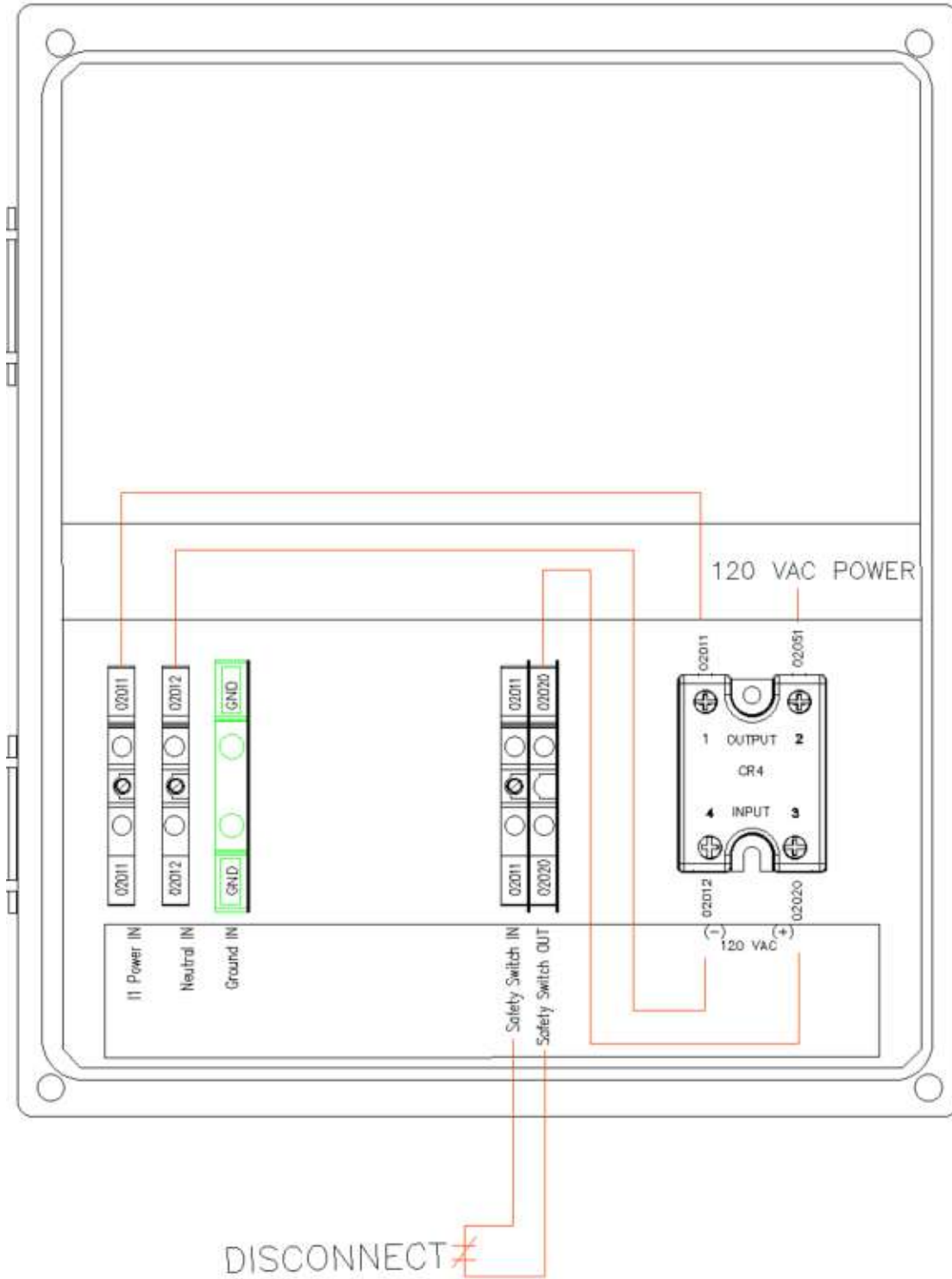

Figure 8-4: VST Control Panel 120 VAC Power Circuit Diagram

8.5 Pressure Sensor Alarm

- A Pressure Sensor Alarm will occur if the PLC is not receiving a 4-20 mA input from the Pressure Sensor, or if there is not 24 VDC power to the Pressure Sensor.
See Figure 8-5.

8.5.1 Pressure Sensor Alarm: Troubleshooting Steps

Steps	Procedures
1.	<ul style="list-style-type: none"> • Check that a Pressure Sensor reading is showing on the Main Screen. <ul style="list-style-type: none"> • If a Pressure Sensor reading is not showing: <ol style="list-style-type: none"> a) There is no 24 VDC power to the Pressure Sensor circuit. b) There is no signal from the Pressure Sensor at the PLC. c) Check the Pressure Sensor power circuit as shown in Figure 8-5. d) Repair the Pressure Sensor power circuit as needed. e) If the power and signal circuits are OK, replace the Pressure Sensor. • If the Pressure Sensor Alarm is still active, call a VST Service Technician.

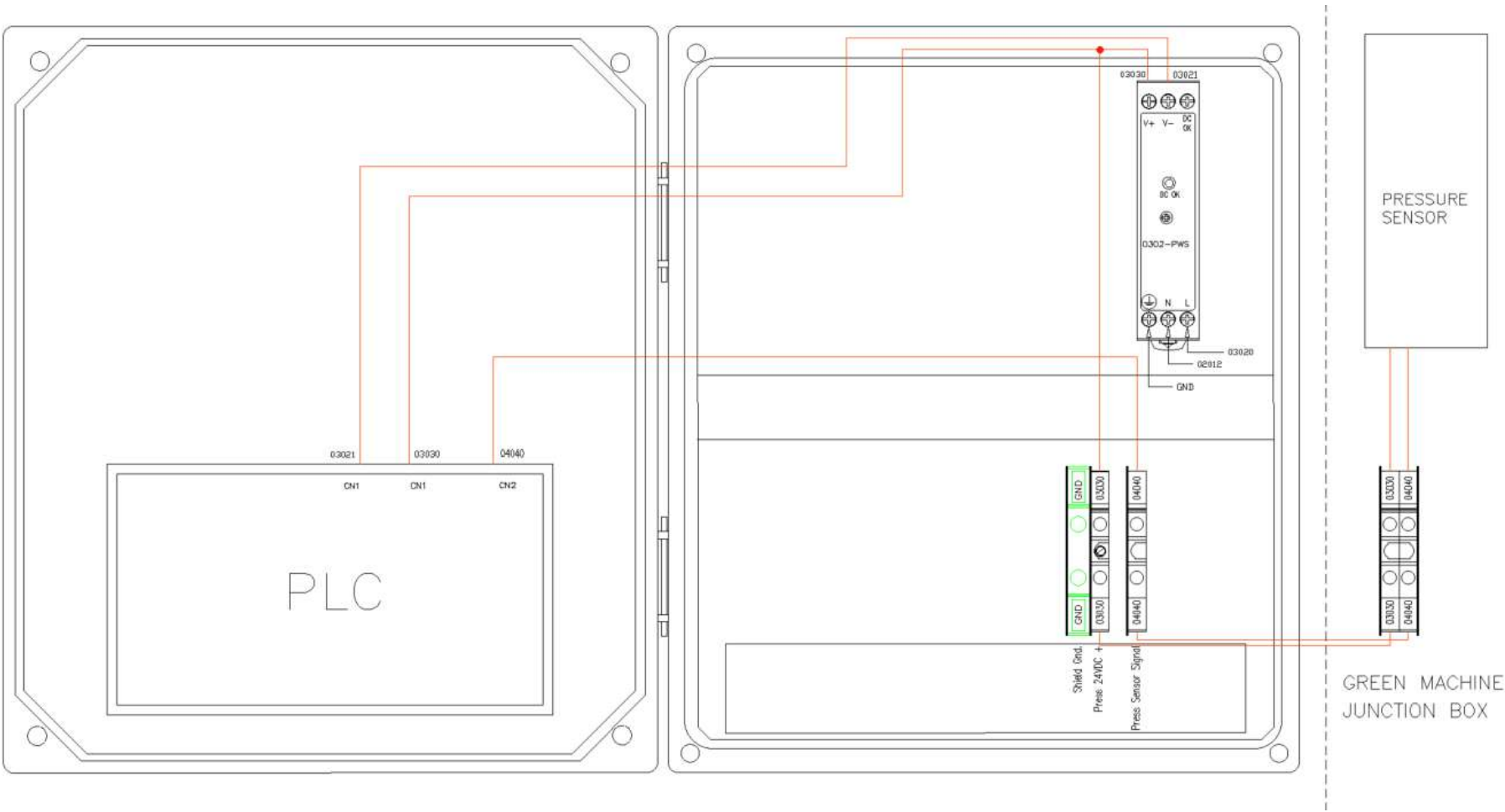
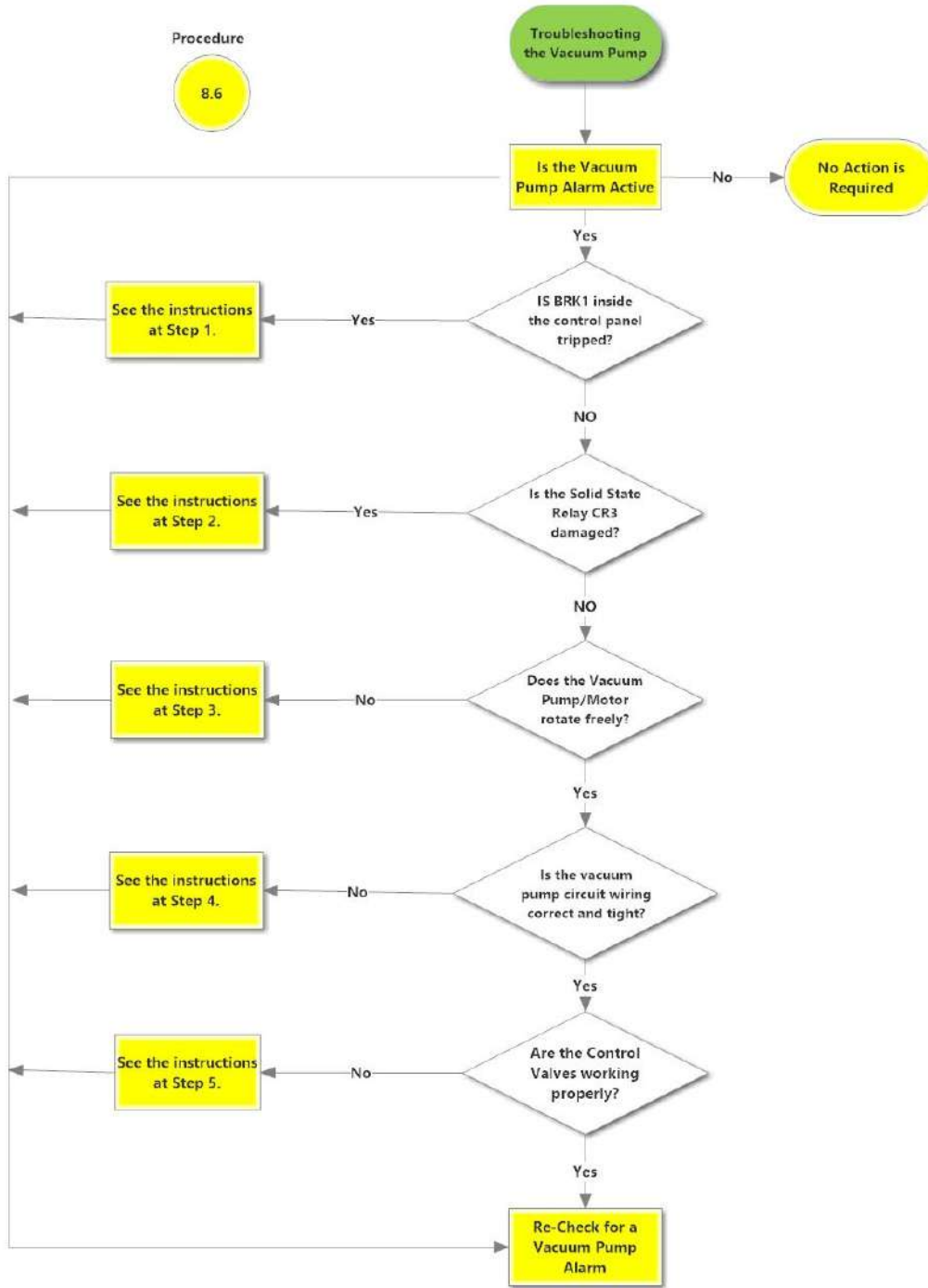

Figure 8-5: Pressure Sensor Wiring Diagram (24VDC Power and 4-20 mA Signal)

8.6 Vacuum Pump Alarm

Vacuum Pump Alarm



Vacuum Pump Motor Alarm, 10-6-2021

Figure 8-6: Vacuum Pump Troubleshooting Procedures

8.6.1 Vacuum Pump Alarm: Troubleshooting Steps

Steps	Procedures
1.	<p>Check to see if the Vacuum Pump breaker (BRK1) in the Control Panel has tripped. See Figure 8-11.</p> <ul style="list-style-type: none">a) Enter the Maintenance screen using the code 878 to disable the GREEN MACHINE.b) Follow lockout & tagout procedures prior to starting work.c) Open the Control Panel front doord) Check the breaker BRK1 to see if it tripped:<ul style="list-style-type: none">● If the breaker lever is up and the window is RED, the breaker has not tripped.● If the breaker lever is down and the window is GREEN, the breaker has tripped.e) If the breaker has not tripped, go to Step 2.f) If the Vacuum Pump breaker has tripped, move the lever up to reset the breaker.g) Push the Clear Motor Alarm button so the alarm resets. See Figure 8-7.h) Push the home button to go back to the Main Screen and the alarm will be cleared.i) The GREEN MACHINE is now in a Normal Operating Mode and will operate if the UST pressure is above 0.2 IWC.j) NOTE: IF THE VACUUM PUMP BREAKER CONTINUES TO TRIP, GO TO STEP 2.

Troubleshooting Procedures, continued

Steps	Procedures
-------	------------

2. Check to see if the Vacuum Pump Solid State Relay is damaged.

- a) Enter the Maintenance screen using the code 878 to disable the GREEN MACHINE.
- b) Follow Lockout/Tagout procedures prior to starting work.
- c) Open the Control Panel front door.
- d) **CAUTION: You are now working in a hot panel**
- e) Push the Clear Motor Alarm button to reset the motor alarm. Without resetting the alarm, you will not be able to do the next step.
- f) Push the Run Tests button. Then push the Functionality Test button. **See Figure 8-8.** This button runs the GREEN MACHINE which allows you to check the voltage on each of the terminals of the solid-state relay. See the table below for expected voltage values of each terminal.

Solid State Relay CR3 – Vacuum Pump Circuit			
Wire Number	Test Probe 1 Location	Test Probe 2 Location	Expected Voltage
02053	Top Left	120 VAC ground	~120 VAC
02054	Top Right	120 VAC ground	~120 VAC
03030	Bottom Left	Bottom Right	~24 VDC
05010	Bottom Right	24 VDC ground	~24 VDC

- g) If any of the voltages are not correct, check the associated breakers, fuses, and wiring for proper connections.
- h) If the wiring connections are all tight, replace the relay. Note the wire numbers and location.
 - i) After the relay is replaced, close the Control Panel front door.
 - j) Push the Clear Motor Alarm button so the alarm resets. **See Figure 8-7.**
 - k) Push the home button to go back to the Main Screen and the Alarm will be cleared.
- m) The GREEN MACHINE is now in a Normal Operating Mode and will operate if the UST pressure is above 0.2 IWC.
- n) **NOTE: IF THE VACUUM PUMP CONTINUES TO ALARM, GO TO STEP 3**



Figure 8-7: Maintenance Screen



Figure 8-8: Tests Screen

Vacuum Pump Alarm: Troubleshooting Steps, continued...

Steps	Procedures
3. Check to see if the Vacuum Pump/motor rotates freely.	<ul style="list-style-type: none">• Physically check the Vacuum Pump to make sure the pump, motor, and drive couplings are functioning correctly.a) Turn off the GREEN MACHINE breaker in the main electrical distribution panel.b) Use Lockout/Tagout Safety procedure.c) Remove the cover on the GREEN MACHINE.d) Remove the fan guard over the Vacuum Pump / motor drive coupling.e) Turn the motor/Vacuum Pump by hand to see if it is seized (cannot rotate). If you cannot turn the shaft between the pump and the motor, loosen the set screws on the motor side of the rubber flange sleeve and slide the coupling towards the motor.f) Turn both the motor and Vacuum Pump sides of the shaft.g) If the Vacuum Pump is seized, REPLACE THE VACUUM PUMP.h) If the motor is seized, REPLACE THE VACUUM PUMP MOTOR.i) If the drive coupling rubber flange sleeve is damaged or jammed, or if you replace either the Vacuum Pump or the Vacuum Pump motor, REPLACE THE RUBBER FLANGE SLEEVE.j) See Chapter 9 for Replacement Parts Procedures.k) Push the Clear Motor Alarm button so the alarm resets.

Vacuum Pump Alarm: Troubleshooting Steps, continued...

Steps	Procedures
<p>4. Check the Vacuum Pump wiring circuit inside the VST Control Panel. See Figure 8-10.</p> <ul style="list-style-type: none"> Physically check the Vacuum Pump wiring connections at the Vacuum Pump junction box and at the VST Control Panel to make sure the connections are tight and wired correctly. <p>5. Check the Control Valves</p> <ul style="list-style-type: none"> Control Valve Operation Check – See Figure 8-9. Check the operation of the control valves (A thru E) to see if any of the control valves have malfunctioned. A malfunctioned control valve may cause the Vacuum Pump motor to trip out on thermal overloads. Purpose of the Test <ul style="list-style-type: none"> The purpose of this test is to check to see if there is power at the control valves and the control valves are working properly. This test is also used for the Leak Test. Preparation <ul style="list-style-type: none"> Make sure power is ON to the VST Control Panel. At the Main Screen, push the Maintenance button to access the Password Screen. Enter the password 878 to access the Maintenance Screen. The GREEN MACHINE is now in the OFF mode and will not operate. Push the Clear Motor Alarm button to reset the motor alarm. Without resetting the alarm, you will not be able to do the next step. 	

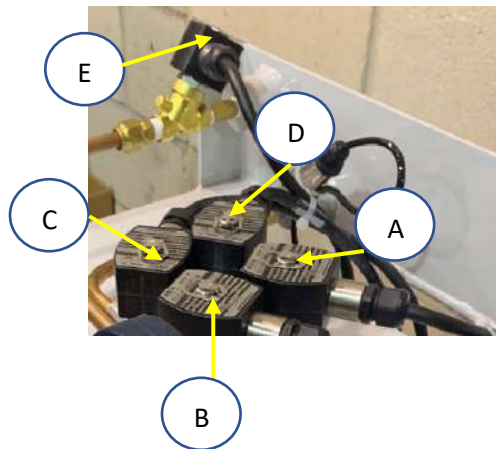

Figure 8-9: Control Valves

Vacuum Pump Alarm: Troubleshooting Steps, continued...

- **Procedure**

1. To start the test, push the Run Tests button on the Maintenance Screen.
See Figures 8-7 and 8-8. Then press the Leak Test button.
2. Check for a magnetic field at the retaining clip in the center of the valve operator.
 - a) Take a small non-magnetized screwdriver that will be drawn to the magnetic field, if one is present, and see if the screwdriver is drawn to the general location of the retainer clip.
 - b) If a valve is not energized, the screwdriver will not be drawn to the retainer clip. **See Figure 8-11** for fuse location.
 - If valve A or C and fuse FU2 are not receiving 120 VAC power, check relay CR1 for damage and replace if necessary.
 - If valve A or C and fuse FU2 has 120 VAC power and is not energized, replace the bad valve core.
 - If valve B or D and fuse FU2 are not receiving 120 VAC power, check relay CR2 for damage and replace if necessary.
 - If valve B or D and fuse FU2 has 120 VAC power and is not energized, replace the bad valve core.
 - If valve E and fuse FU2 are not receiving 120 VAC power, check relay CR5 for damage and replace if necessary.
 - If valve E and fuse FU2 has 120 VAC power and is not energized, replace the bad valve core.
 - c) If the magnetic fields are present, listen for any of the control valves making a chattering sound. If chattering is heard, replace the valve core.
 - d) Replace the valve core using the Core Rebuilt Kit as shown in the Replacement Parts Section. See Chapter 9 for Replacement Parts Procedures.
3. After checking and replacing the Control Valves, push the home button to return to the Main Screen.

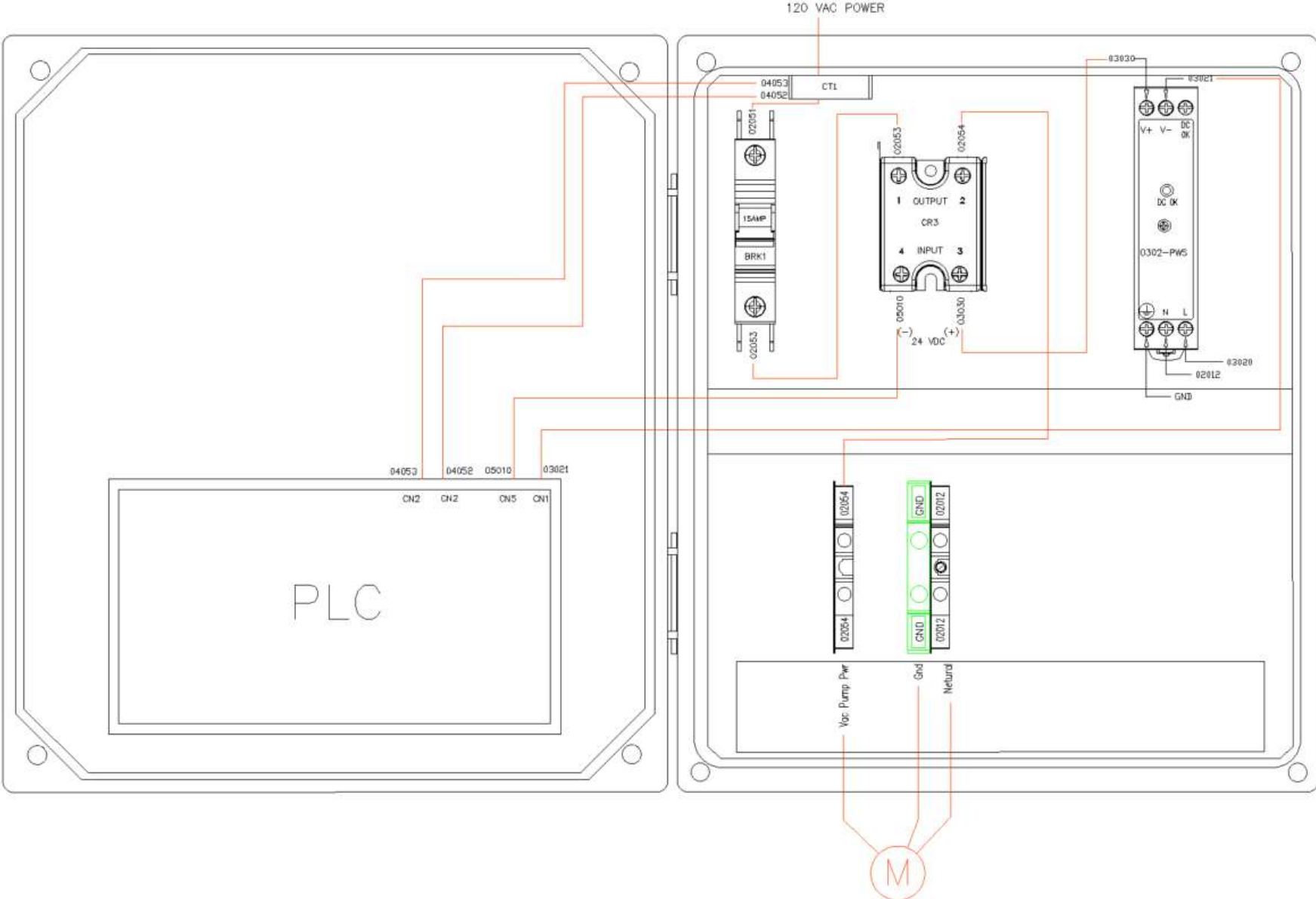

Figure 8-10: Vacuum Pump Circuit

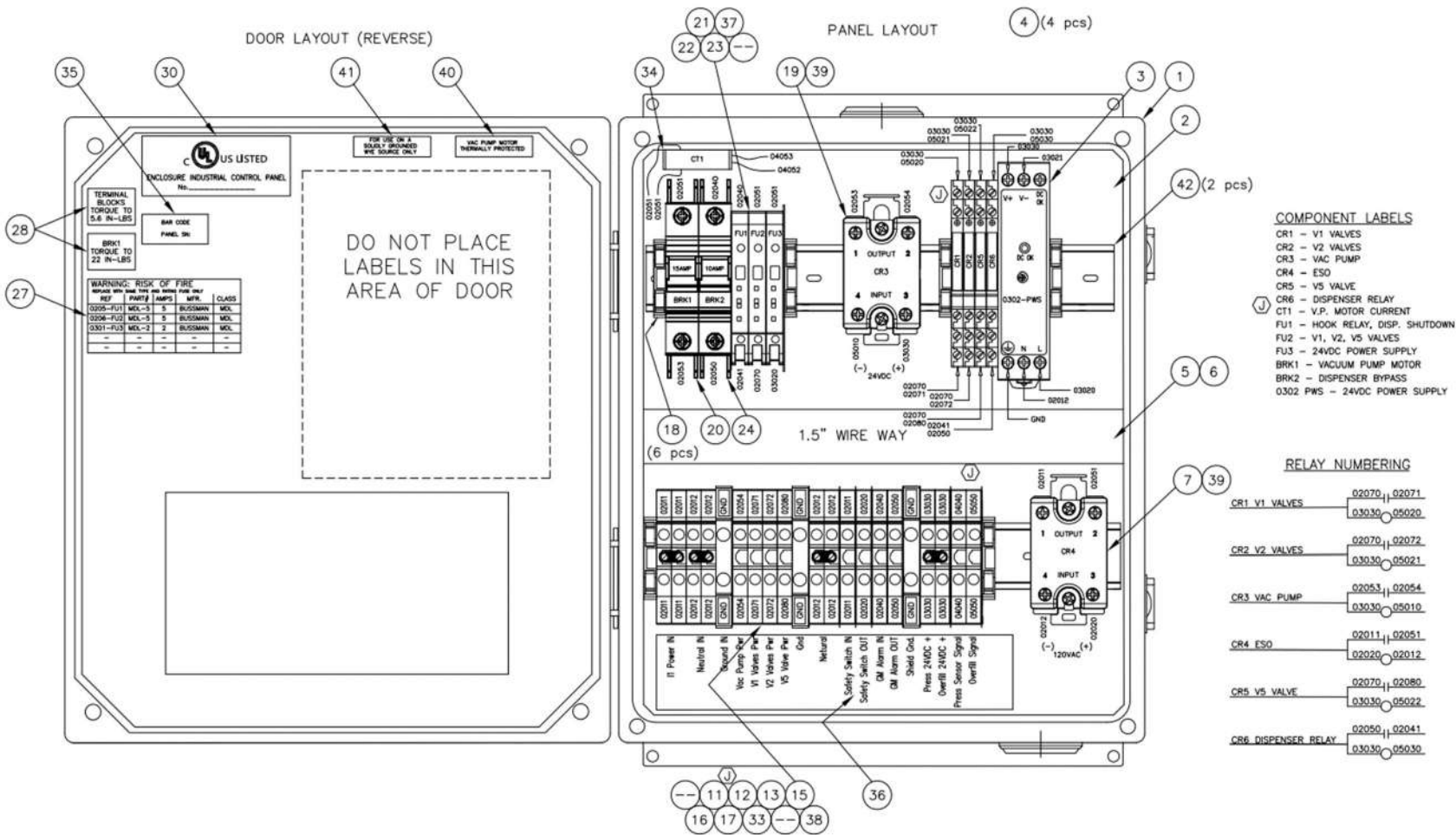

Figure 8-11: VST Control Panel Electrical Components

8.7 Overfill Alarm



Figure 8-12: GREEN MACHINE PLC Alarm Screen

- A VST Control Panel PLC Overfill Alarm is Active when the Fuel Management System Overfill Alarm is Active. **See Figure 8-12.**
- An overfill condition exists when, during a fuel drop, the gasoline level in the UST exceeds the Overfill Alarm setting, which is 90% capacity of the UST. **See Figure 8-13.**
 - The VST Control Panel is connected to the Tank Overfill Alarm output relay.
 - When an overfill occurs, the output (N.C.) relay opens and GREEN MACHINE will turn OFF.
 - The Overfill Alarm box will display RED indicating an Overfill Alarm is active.
 - When the gasoline level drops below the Overfill Alarm level, the output relay closes and the alarm clears. The GREEN MACHINE will remain OFF for 2 additional hours.
 - After the 2 hours elapse:
 - The Overfill Alarm box will not be shown on the Fault and Alarm Screen.
 - The GREEN MACHINE will turn ON if the UST pressure is above 0.2 IWC.
 - The GREEN MACHINE will remain OFF if the UST pressure is below 0.2 IWC.

8.7.1 Overfill Alarm Troubleshooting Steps

Steps	Procedures
<ol style="list-style-type: none"> 1. An overfill may cause the Vacuum Pump to seize, which may cause the Vacuum Pump motor to trip out on the thermal overloads. 2. If an Overfill Alarm Activates while a test is running: <ul style="list-style-type: none"> • The test will terminate. • The Fault and Alarm Screen is displayed and the Overfill Alarm box will display RED. • An underground storage tank overfill is a serious situation that could damage internal components in the GREEN MACHINE. • An overfill might happen if the delivery person fails to stop fueling, ignoring both the overfill limit and the high-product limit. • VST has determined that overfill protection is needed to reduce the chance of gasoline entering the GREEN MACHINE. • Below are the precautionary measures taken to protect the GREEN MACHINE against an overfill situation: <ul style="list-style-type: none"> • The VST Control Panel will disable the GREEN MACHINE when the UST level reaches the OVERFILL Alarm setting (OVERFILL: 90%) when the relay contacts close at the Fuel Management System. • Eventually, as fuel is dispensed, the product would drop below the OVERFILL Alarm threshold thereby resetting the relay and re-enabling the GREEN MACHINE. • The Fuel Management System OVERFILL ALARM will not guarantee that the GREEN MACHINE is protected from gasoline entering it. 3. The table below lists the VST recommended alarm settings for the tank level. 	

Position of Tank Alarm Limits	VST Recommended Alarm Settings
Overfill Limit	90%

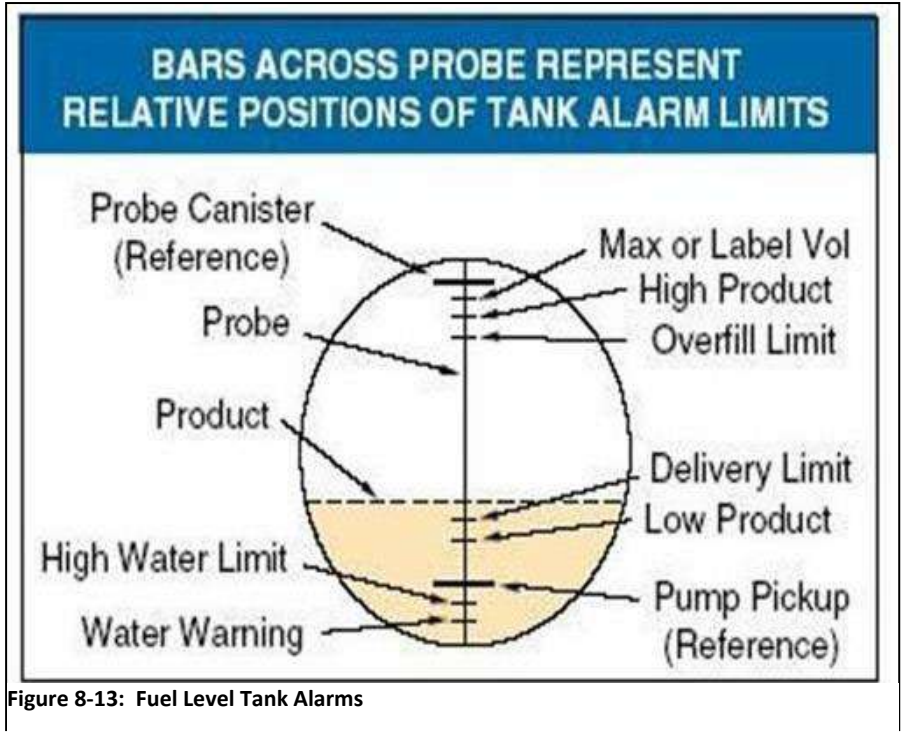

Figure 8-13: Fuel Level Tank Alarms

Overfill Report		
Date:		
Contractor Name:		
Contractor Company:		
GDF Name:		
Address:		
City:	State:	ZIP Code:
GDF Contact Person Name:		
GDF Contact Person Title:		
GDF Contact Person Phone:		
GDF Contact Person E-mail:		
Overfill Details		
Date of Overfill:		
Octane of the fuel being dispensed:		
Serial Number of the GREEN MACHINE:		

8.8 Data Storage Alarm

- The GREEN MACHINE will operate when there is a Data Storage Alarm, but the card will not or cannot record the data.
- The Data Storage Alarm will activate when the following items occur:
 1. A digital storage drive is not installed in the PLC slot.
 2. When the digital storage drive is not inserted into the slot properly.
- Correct the above problem(s) and the Data Storage Alarm will clear.

Chapter 9: Replacement Procedures

9 Replacement Parts Procedures

9.1 List of Replacement Parts

- The GREEN MACHINE parts shown in the picture and table below must be supplied by VST. See Figure 9-1.

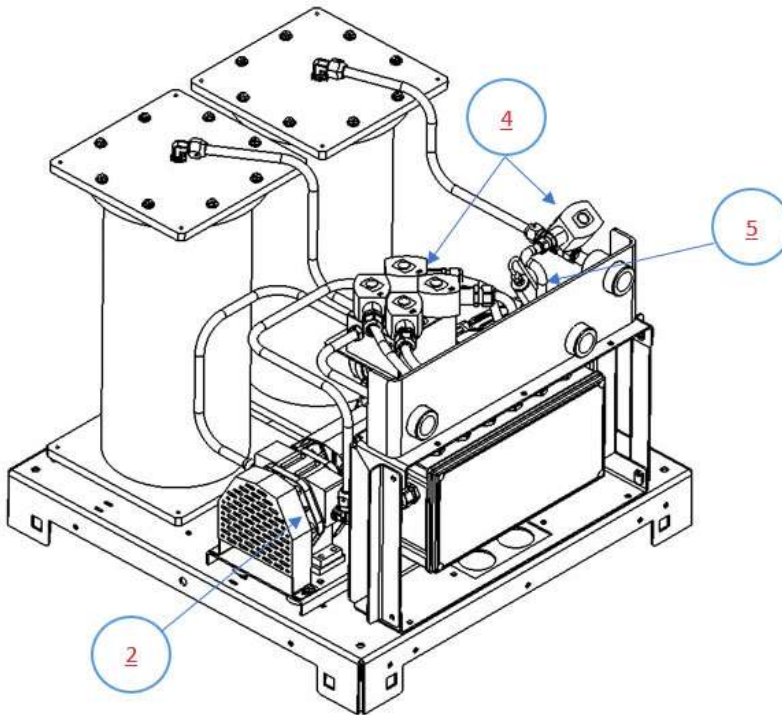

Figure 9-1: GREEN MACHINE Replacement Parts

VST GREEN MACHINE Replacement Parts			
Ref. #	Description	Part No.	Manufacturer
1	VACUUM PUMP MOTOR (ONLY), 120VAC, SINGLE-PHASE (not shown)	GM-027	VST
2	MODEL 2 VACUUM PUMP (ONLY)	GM-042	
3	RUBBER FLANGE SLEEVE (not shown)	GM-004	
4	UL CONTROL VALVES – CORE REBUILD KIT	GM-006	
5	PRESSURE SENSOR	GM-067	

9.1.1 VST Control Panel Replacement Parts

- See Figure 9-2.

VST GREEN MACHINE Replacement Parts			
Ref. #	Description	Part Number	Manufacturer
	GREEN MACHINE™ Control Panel (Complete)	GM-073	VST

VST GREEN MACHINE Control Panel (Sub-Component) Replacement Parts			
Ref. #	Description	Part Number	Manufacturer
3	24VDC POWER SUPPLY, 1A	GM-075	VST
4	TERMINAL RELAY, 24V AC/DC, SPDT	RV8H-L-AD24	IDEC
7	SOLID STATE RELAY, 25A, SPST, 90-280 INPUT, N.O., 90-280 VAC LOAD	GM-065	VST
19	SOLID STATE RELAY, 10A, 24VDC COIL	GM-060	VST
20	MINI CIRCUIT BREAKER, 15A, UL489	GM-061	VST
21	FUSE HOLDER	V7-H6	SPRECHER+SCHUH
22	5 A GLASS FUSE	MDL-5	BUSSMANN
23	2 A GLASS FUSE	MDL-2	BUSSMANN
24	MINI CIRCUIT BREAKER, 10A, UL489	L9-10/1/D	SPRECHER+SCHUH
34	ANALOG CURRENT TRANSDUCER	SCT013	POWERUC ELECTRONICS

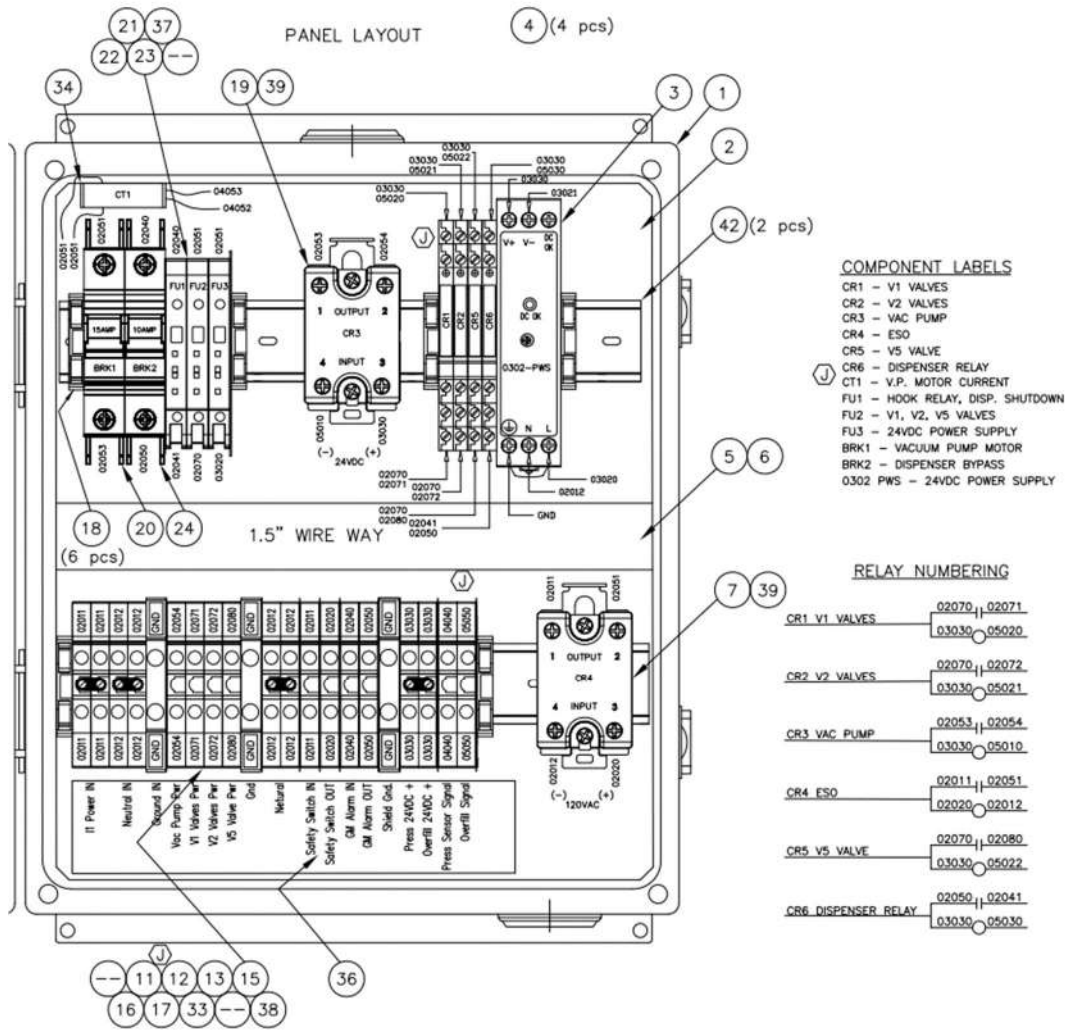

Figure 9-2: VST Control Panel, Inside Panel Replacement Parts

9.1.2 Replacement Procedures by Part

9.2 Control Panel Small Components Replacement

9.2.1 Vacuum Pump Motor Breaker Replacement

9.2.2 Vacuum Pump Motor Solid State Relay Replacement

9.3 Pressure Sensor Replacement

9.4 Rubber Flange Sleeve Replacement

9.5 Control Valve Replacement

9.6 Vacuum Pump (Only) Replacement

9.7 Leak Test

9.2 Control Panel Small Components Replacement

9.2.1 Vacuum Pump Motor Breaker Replacement

Safety



Use lockout / tagout procedures prior to starting work.

9.2.1.1 Removing the Vacuum Pump Motor Breaker

- **See Figure 9-2, and 9-3.**
 1. Turn off the GREEN MACHINE breaker in the main electrical distribution panel.
 2. Follow lockout & tagout procedures prior to starting work.
 3. Unlock the metal clasps on the right-hand side of the Control Panel and open the Control Panel door.
 4. Find the Vacuum Pump motor breaker (**See Figure 9-2, item #20**) and note the wire numbers and locations. **See Figure 9-3.**
 5. Using a screwdriver, loosen the two screws on the top and bottom of the breaker. Remove the two wires.
 6. Pull up on the small black release mechanism on the bottom side of the breaker and rotate the breaker out of the Control Panel.

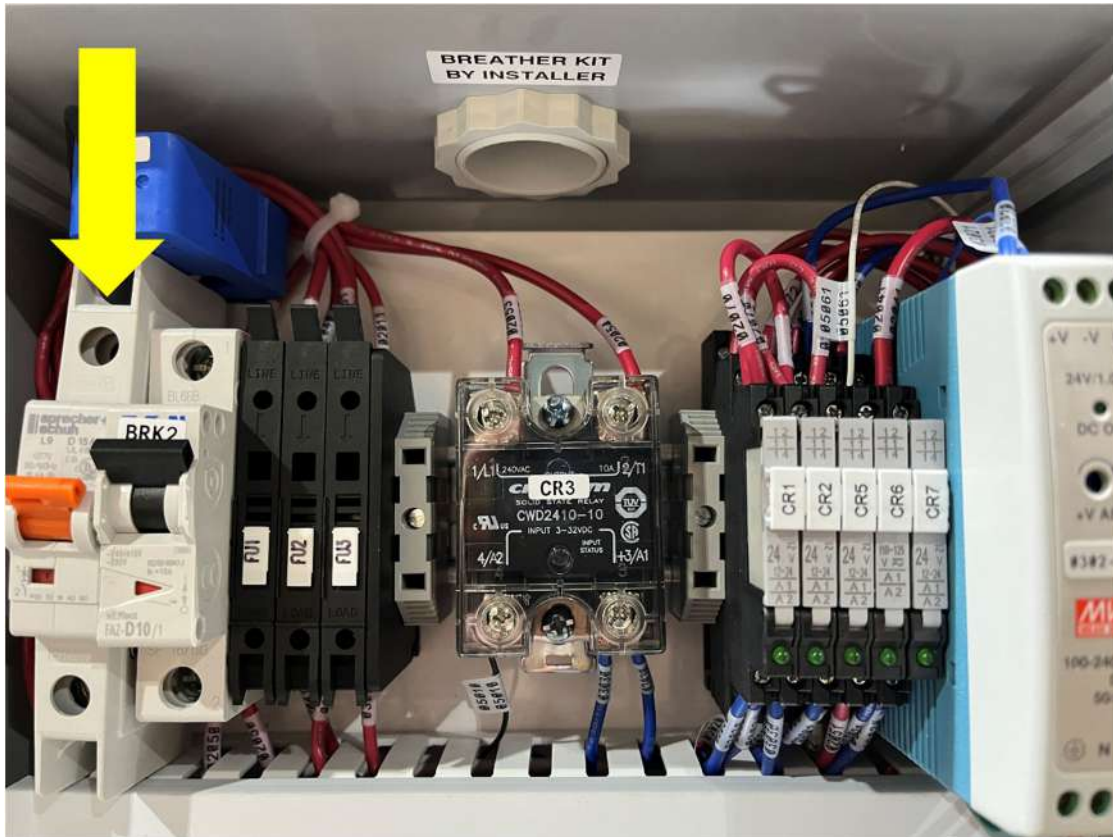

Figure 9-3: Vacuum Pump BRK1

9.2.1.2 Replacing the Vacuum Pump Motor Breaker

See Figure 9-3.

1. Install the new breaker, hooking the top of the breaker on first and then pushing the bottom of the breaker down into place.
2. Using a screwdriver, reinstall the two wires.
3. Be sure the switch on the breaker is in the UP position. **See Figure 9-3.**
NOTE: The small window below the switch should be RED. If the window is GREEN, flip the switch so that the window is RED.
4. Close the Control Panel door and lock the 2 metal clasps on the right-hand side of the Control Panel.
5. Remove locks and tags from lockout tagout.
6. Turn on the power to the GREEN MACHINE.
7. If there is an alarm on the Main Screen, refer to Vacuum Pump Alarm in the Troubleshooting chapter.

9.2.2 Vacuum Pump Motor Solid-State Relay Replacement Safety



Use lockout / tagout procedures prior to starting work.

9.2.2.1 Removing the Solid State Relay

- **See Figures 9-2, and 9-4.**
 1. Turn off the GREEN MACHINE breaker in the main electrical distribution panel.
 2. Follow lockout & tagout procedures prior to starting work.
 3. Unlock the metal clasps on the right-hand side of the Control Panel and open the Control Panel door.
 4. Find the Vacuum Pump solid-state relay (see **Figure 9-2, item #19**) and note the wire numbers and locations. **See Figure 9-4.**
 5. Using a screwdriver, remove the five wires from the four terminals. **See Figure 9-4.**
 6. Remove the top screw and loosen the bottom screw securing the solid-state relay to the Control Panel. The solid-state relay can now be removed by sliding up.

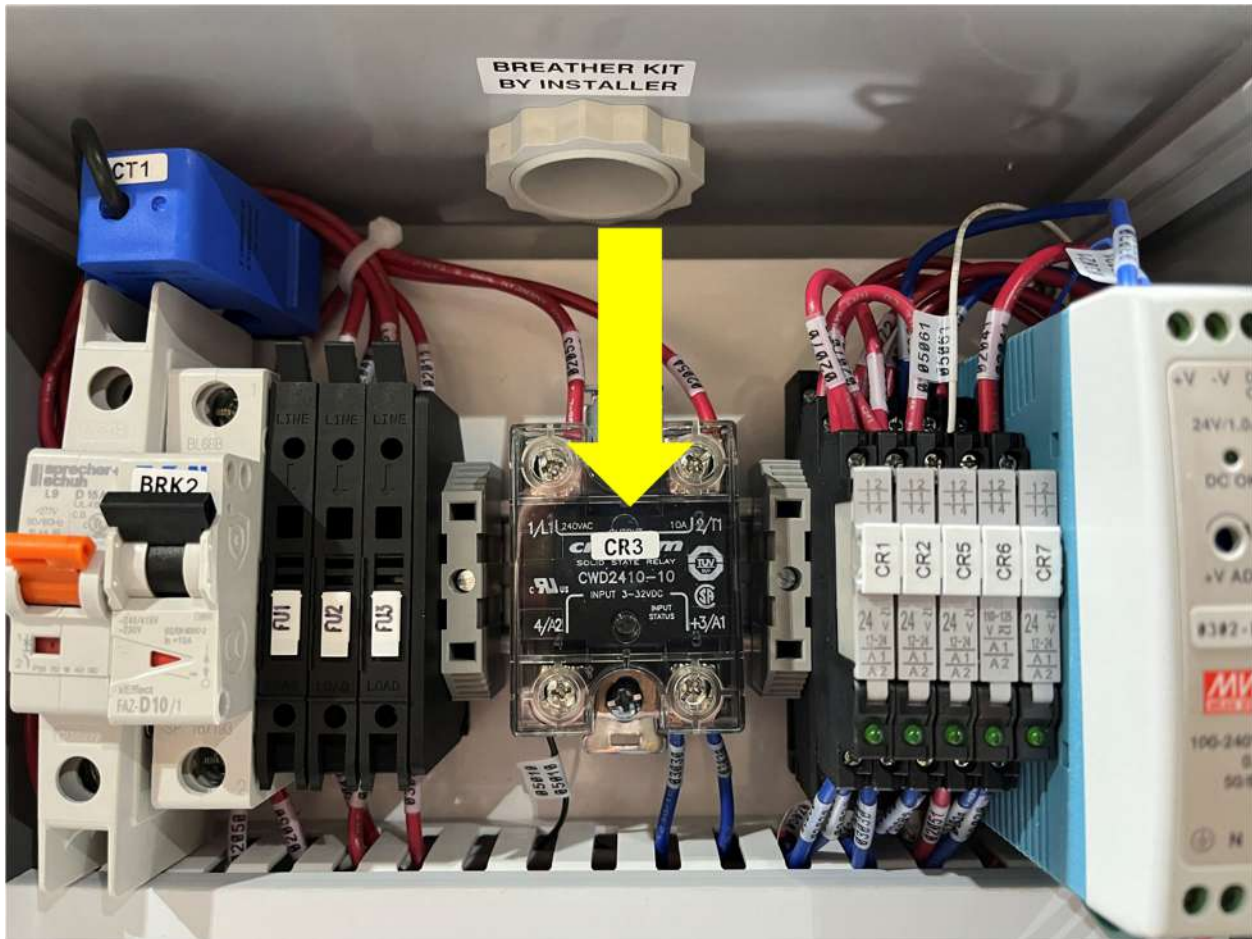

Figure 9-4: Vacuum Pump Solid State Relay

9.2.2.2 Replacing the Solid State Relay

- See Figure 9-4.
 1. Install the new solid-state relay, sliding it down into place onto the bottom screw.
 2. Using a screwdriver, reinstall and tighten the top screw, then tighten the bottom screw.
 3. Reinstall the wires to the appropriate contacts. The bottom VDC wires must be installed as shown in **Figure 9-4** because of polarity.
 4. Close the Control Panel door and lock the 2 metal clasps on the right-hand side of the Control Panel.
 5. Remove locks and tags from lockout tagout.
 6. Turn on the power to the GREEN MACHINE.
 7. If there is an alarm on the Main Screen, refer to Vacuum Pump Alarm in the Troubleshooting chapter.

9.3 Pressure Sensor Replacement

Safety



Use lockout / tagout procedures prior to starting work.

9.3.1 Removing the Pressure Sensor

- **See Figure 9-5 and 9-6.**
 1. Turn off the GREEN MACHINE breaker in the main electrical distribution panel.
 2. Follow lockout & tagout procedures prior to starting work.
 3. Unscrew the 8 cover screws and remove the cover from the GREEN MACHINE.
 4. Remove the cover from the Internal Junction Box.
 5. Remove the Pressure Sensor from the pressure sensor port.
 6. Disconnect the 3 Pressure Sensor wires from the terminal block inside the Internal Junction Box. **See Figure 9-5.**

9.3.2 Installing the Pressure Sensor

- **See Figure 9-5 and 9-6.**
 1. Install the new Pressure Sensor. Use gasoline resistant PTFE tape on the pipe threads.

CAUTION: Be sure to tighten the Pressure Sensor using the nut on the bottom of the sensor during the installation.
 2. Connect the Pressure Sensor wires to the terminal blocks inside the Internal Junction Box. **See Figure 9-5.**
 - Red to 03030
 - White to 04040
 - GND to GND
 3. Install the Internal Junction Box cover.
 4. Remove the lock(s) and tags from the lockout & tagout.
 5. On the Control Panel, tap the home button.
 6. Verify Pressure Sensor Alarm is not active and the pressure reading on the PLC is 0.00 +/- 0.10 IWC.
 7. Put the cover on the GREEN MACHINE and screw on the 8 cover screws.
 8. The GREEN MACHINE is now operational.

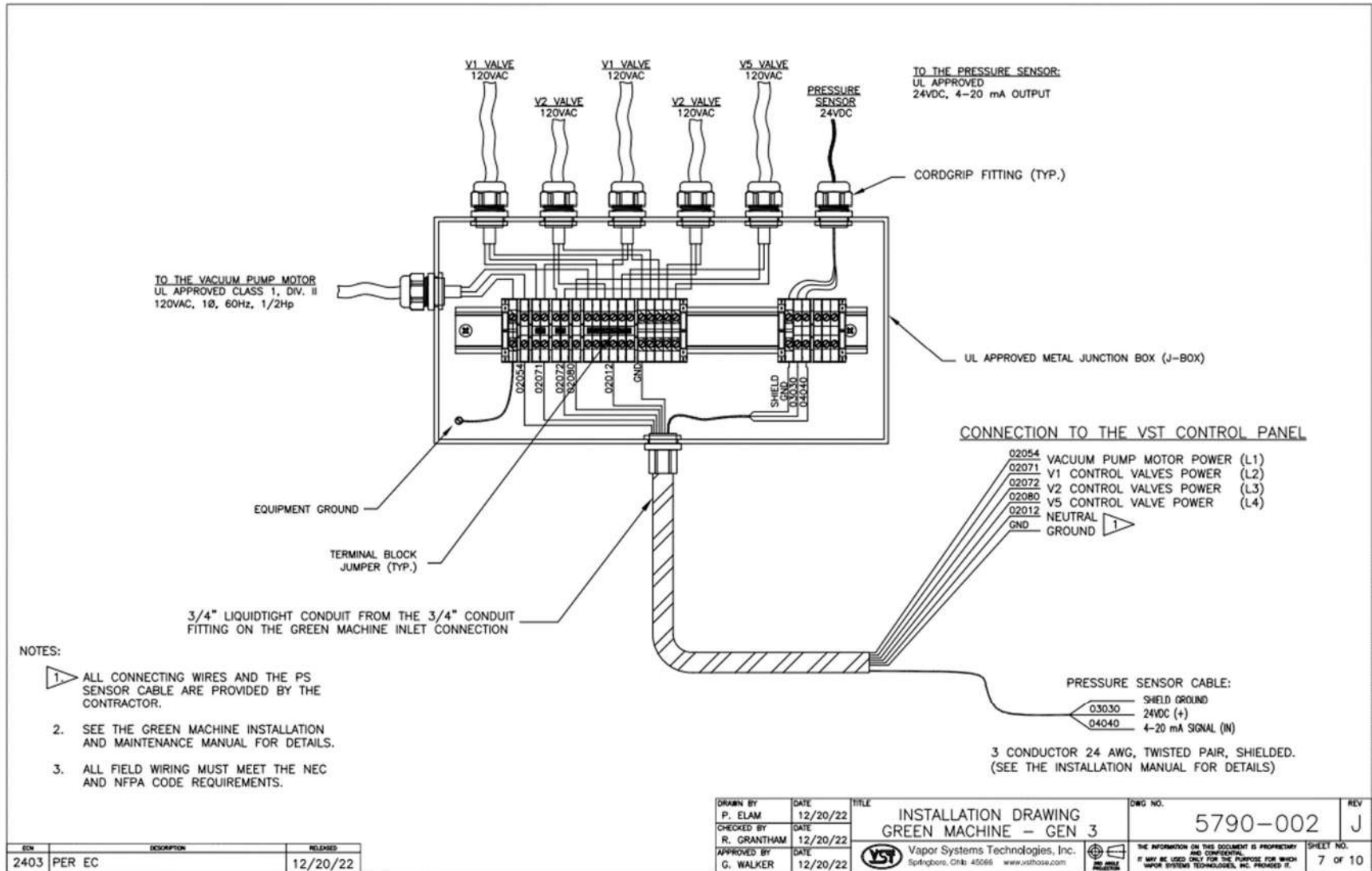

Figure 9-5: Wiring the Pressure Sensor Inside the Internal Junction Box

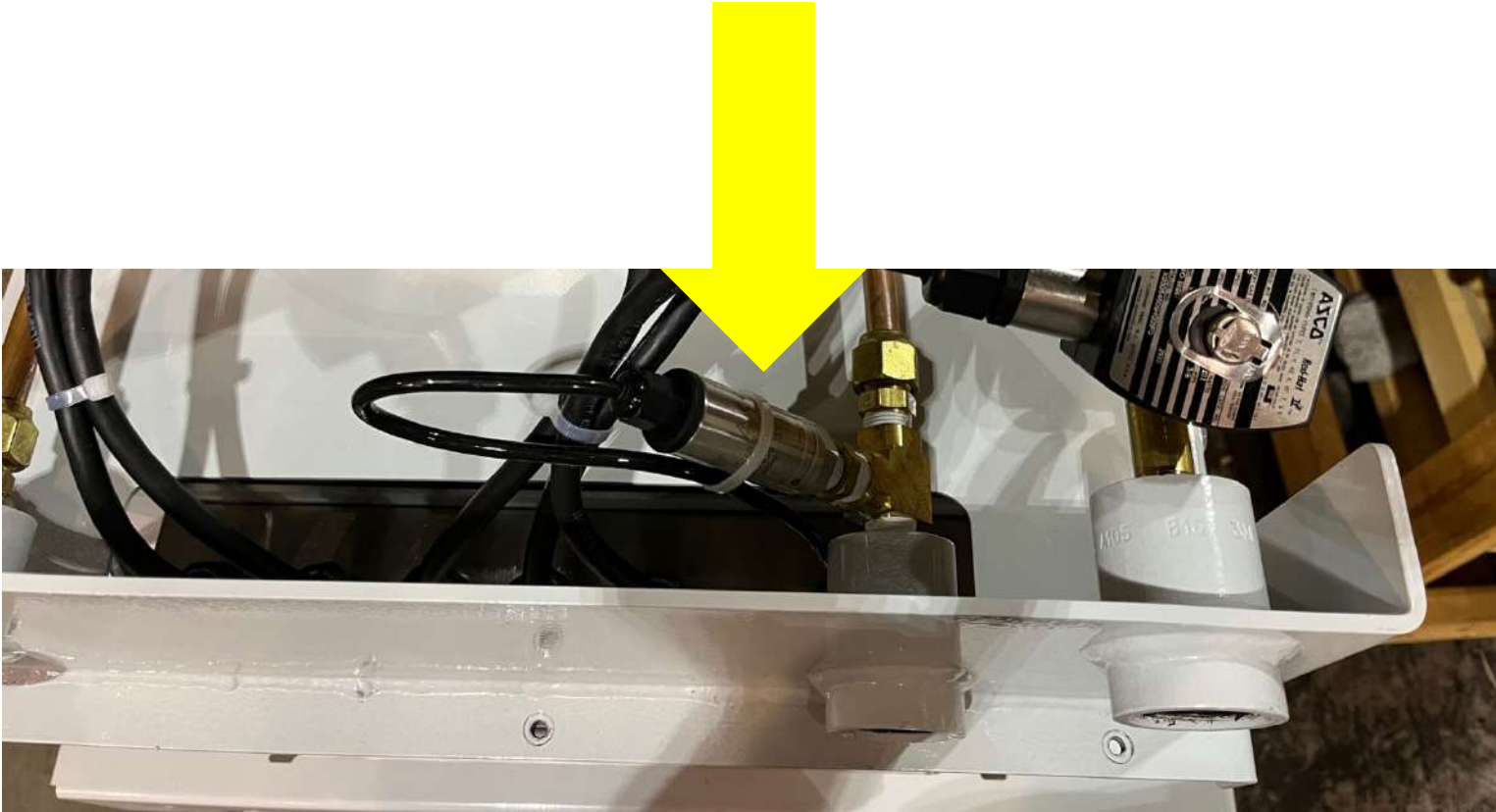

Figure 9-6: Pressure Sensor Installed in GREEN MACHINE

9.4 Rubber Flange Sleeve Replacement

Safety



Use lockout / tagout procedures prior to starting work.

VST recommends replacing the Rubber Flange Sleeve every time Maintenance is performed on the GREEN MACHINE even if the Rubber Flange Sleeve does not look damaged or worn.

NOTE: The Rubber Flange Sleeve replacement is done with the vacuum pump motor assembly still attached to the GREEN MACHINE base.

9.4.1 Removing the Rubber Flange Sleeve

See Figure 9-7.

1. Turn off the GREEN MACHINE breaker in the main electrical distribution panel.
2. Follow lockout & tagout procedures prior to starting work.
3. Unscrew the 8 cover screws and remove the cover from the GREEN MACHINE.
4. Remove the two tubes attached to the pump.



Figure 9-7: Two tubes removed from vacuum pump

5. Remove the side fan guard.

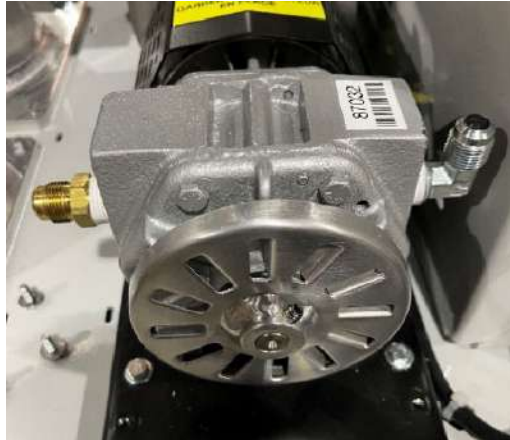

Figure 9-8: Side Fan Guard Removed

6. Remove the 4 vacuum pump mounting bolts. Keep the shims and 4 bolts for reuse.



Figure 9-9: Vacuum Pump Mounting Bolts

7. Slide the pump away from the motor so the rubber flange sleeve can be removed.

9.4.2 Replacing the Rubber Flange Sleeve

1. Insert a new rubber flange sleeve and slide the pump back to its original position.
 - Make sure the motor-side drive coupling is snug (not tight) against the rubber flange sleeve.
2. Replace any shims that moved while moving the pump.
3. Re-install and tighten the 4 pump mounting bolts to the base plate. Make sure the Motor Shaft and Vacuum Pump shafts are in alignment.
4. Re-install the fan guard over the coupling flanges, and the side fan guard.
5. Put the cover on the GREEN MACHINE and screw on the 8 cover screws.
6. Remove the lock(s) and tags from the lockout & tagout.
7. After the work is completed, return to the Main Screen on the VST Control Panel. The GREEN MACHINE is now operational.

9.5 Control Valve Replacement

9.5.1 Removing the Valve Solenoid and Core Assembly

See Figures 9-10 & 9-11.

1. Turn off the GREEN MACHINE breaker in the main electrical distribution panel.
2. Follow lockout & tagout procedures prior to starting work.
3. Unscrew the 8 cover screws and remove the cover from the GREEN MACHINE.
4. Unlock and close the three ball valves between the GREEN MACHINE and the vent risers.
5. Remove the retaining clip from the solenoid that is not working.
6. Remove the nameplate by pushing the solenoid down towards the valve body, then lift and slide the nameplate off.
7. Slide the solenoid off the solenoid base. DO NOT lose the spring washer located below the solenoid on the solenoid base.
8. Using a 1" wrench, remove the solenoid base from the manifold, the core assembly with core spring, and the body gasket. Discard the used components.

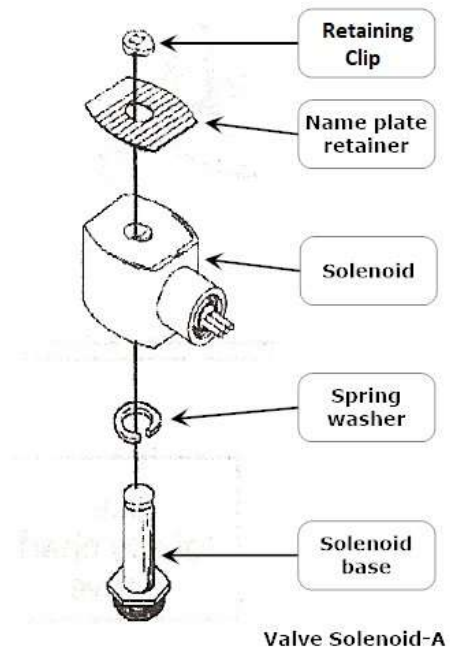

Figure 9-10: Valve Solenoid Assembly

9.5.2 Replacing the Valve Solenoid and Core Assembly

See Figure 9-11.

1. Install a new Core Assembly which includes:
 - Solenoid base
 - Core assembly with core spring
 - Body gasket
2. Screw the solenoid base and tighten with a 1" wrench until tight. Make sure to install the body gasket with the solenoid base.
3. Place the spring washer on the solenoid base, then slide the solenoid on to the solenoid base.
4. Slide and lock the nameplate on the solenoid.
5. Snap the retaining clip on the solenoid base.
6. Open the three ball valves between the GREEN MACHINE and the vent risers and lock in the OPEN position.

CAUTION: THREE BALL VALVES BETWEEN THE GREEN MACHINE AND THE VENT RISERS MUST BE OPEN BEFORE APPLYING POWER TO THE VST CONTROL PANEL TO AVOID DAMAGE TO THE GREEN MACHINE INTERNAL EQUIPMENT.

7. Put the cover on the GREEN MACHINE and screw on the 8 cover screws.
8. Remove the lock(s) and tags from the lockout & tagout.
9. On the Control Panel, tap the home button. The GREEN MACHINE is now operational.

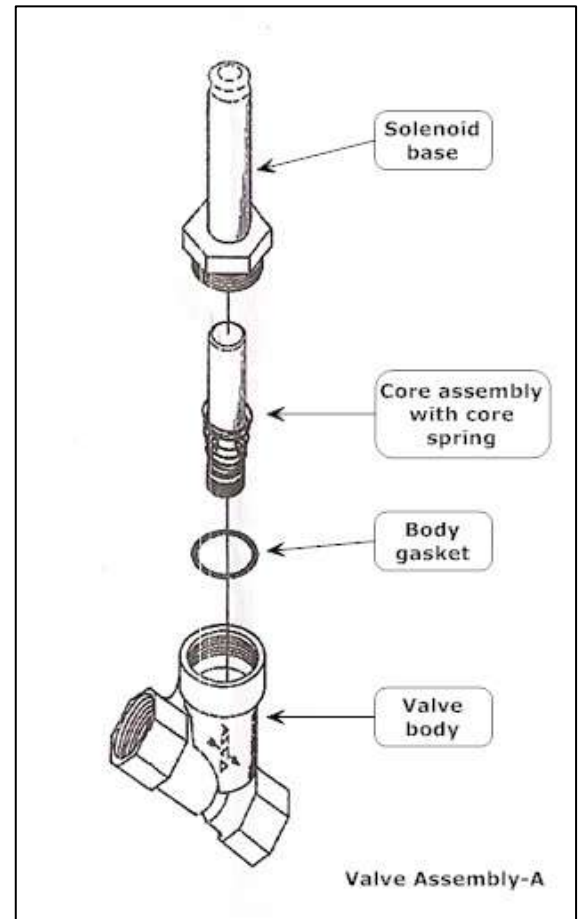

Figure 9-11: Valve Assembly

9.6 Vacuum Pump (Only) Replacement

9.6.1 Preparation for Cleaning the Tubes and Manifold

1. Turn off the GREEN MACHINE breaker in the main electrical distribution panel.
2. Use Lockout/Tagout Procedures prior to starting work.
3. Unlock and close the 3 isolation valves between the GREEN MACHINE and the vent risers.
4. Unscrew the 8 cover screws and remove the cover from the GREEN MACHINE.
5. Remove 6 tubes from the GREEN MACHINE. **See Figures 9-12 & 9-13.**



Figure 9-12: Piping to be removed



Figure 9-13: Piping removed

CAUTION: The tube ends are a Parker 45° flare, use caution not to damage the flared ends on the tubing or the threads on the nuts after removal.

9.6.2 Removing the Vacuum Pump

1. For the Vacuum Pump Assembly and Components, See Figure 9-14.

NOTE: The Motor will not be affected during the replacement of the Vacuum Pump.

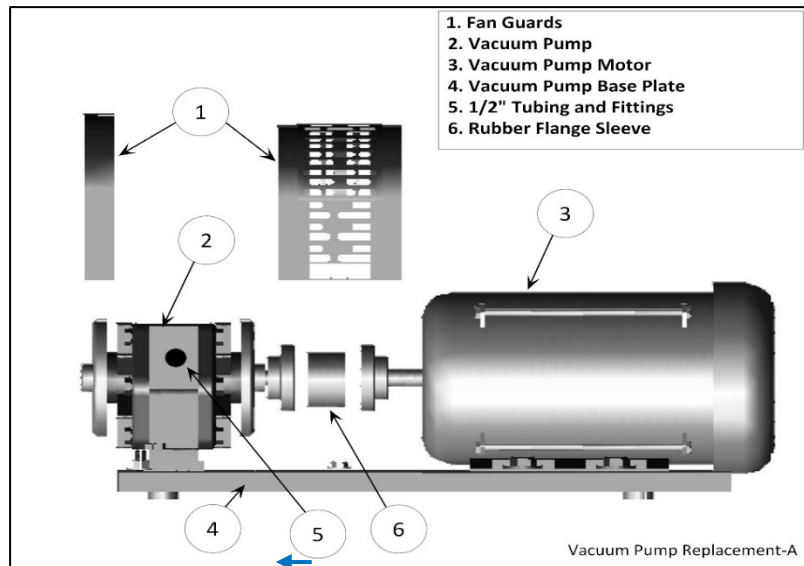

Figure 9-14: Vacuum Pump Assembly and Components

2. Remove the brass pipe fittings from both sides of the Vacuum Pump and keep for reuse.



Figure 9-15: Two Tubes Removed from Vacuum Pump

CAUTION: The fittings are a Parker 45° flare, use caution not to damage the 45° flare fittings or the threads after removal.

3. Remove the side fan guard.

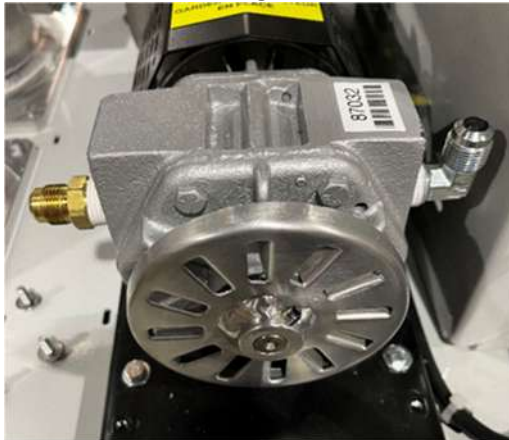

Figure 9-16: Side Fan Guard Removed

4. Remove the 4 mounting bolts from the Vacuum Pump base and keep for re-use.



Figure 9-17: Vacuum Pump Mounting Bolts

CAUTION: There may be metal shims under the Vacuum Pump. They must be marked for location and saved for re-use.

5. Remove the Vacuum Pump.
6. Remove the rubber flange sleeve and discard.

The rubber flange sleeve between the Vacuum Pump and the motor must be replaced with each new pump.

9.6.3 Replacing the Vacuum Pump

1. The new pump will come with a drive coupling and rubber flange sleeve.
See Figure 9-14.
2. Install the flange coupling on to the pump shaft. Then install the rubber flange sleeve into the pump flange coupling so that when the pump is installed, the rubber flange sleeve mates with the motor flange coupling.
3. Place the new Vacuum Pump on the base and align the mounting holes. Remember to re-install the shims under the Vacuum Pump.
4. Reinstall and tighten the 4-Vacuum Pump mounting bolts so the pump shaft aligns with the motor shaft.
5. Slide the drive-coupling flange over the rubber flange sleeve so both halves of the coupling are snug (not tight) against the rubber flange sleeve and tighten the set screws. Double check to make sure both coupling set screws are tight.
6. Wrap the pipe fitting threads with gasoline resistant PTFE tape a maximum of three revolutions and reinstall the pipe fittings.
7. Re-install the fan guards.

9.6.4 Preparation for Cleaning the Tubes and Manifold

1. On the manifold, remove the Solenoids A, B, C, and D from the 4 Control Valves located on the manifold. Do not remove Solenoid E. **See Figure 9-18.**
2. Remove the Retaining Clip from the Solenoid Base and the Nameplate/Retainer and keep for reuse. **See Figure 9-19.**
3. Slide the Solenoid off the Solenoid Base. **See Figure 9-20.**
4. Remove the Spring Washer from the Solenoid Base and keep for reuse.
5. Use a 1" wrench to remove the Solenoid Base from the Valve Body. Keep the Solenoid Base, the Core Assembly and Body Gasket for reuse. **See Figures 9-21.**
6. Place the empty Solenoid Base inside the Solenoid, then attach the Retaining Clip. Do this for all four Solenoids. **See Figures 9-22.**
WARNING: The Solenoid Base MUST BE INSTALLED inside the Solenoid so the magnetic field around the Solenoid will not breakdown when power is applied to the Solenoid.
7. Move the four Solenoids out of the way of the manifold. **See Figure 9-22.**
8. The Manifold is now ready to clean. **See Figure 9-22.**
9. Install the provided Blowout Tube with the clear plastic tubing attached to the discharge side of the Vacuum Pump. Tighten the 45° nut on the fitting hand tight. **See Figure 9-23.**
CAUTION: Do not use any thread sealing compound when assembling the 45° flare nuts on the tubes

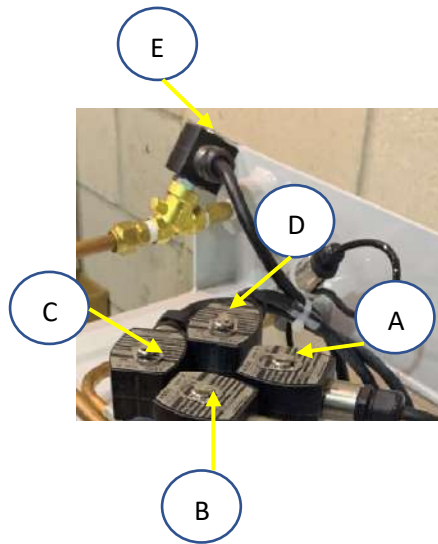

Figure 9-18: Manifold Valves

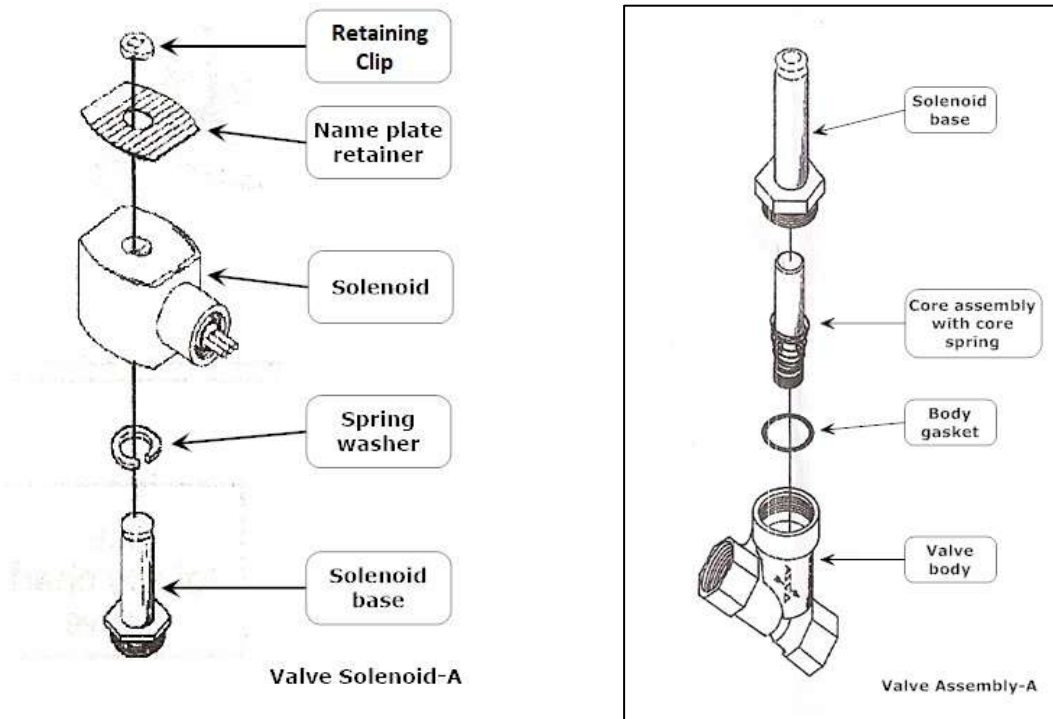

Figure 9-19: Valve Solenoid Assembly



Figure 9-20: Manifold with the Solenoids Removed, showing the Solenoid Bases



Figure 9-21: Solenoids Arranged Out of the Way



Figure 9-22: Solenoids with the Core Assembly Inside



Figure 9-23: Vacuum Pump with the Blowout tube

9.6.5 Cleaning the Tubes and Manifold

1. At the VST Control Panel, remove the Lockout/Tagout lock(s).
2. At the Maintenance Screen, push Run Tests button, then the Functionality Test button to operate the Vacuum Pump. This will allow the Vacuum Pump to blow outside air through the plastic tube. **See Figure 9-24.**

WARNING: Safety Glasses MUST BE USED when blowing out the Tubes and Manifold.

3. Using the plastic tube, blow air through the 6 removed copper tubes to remove any potential debris. **See Figure 9-13.**
4. The Cleaning of the tubes and manifold is complete.
5. At the VST Control Panel Functionality Test Screen, stop the test by pressing the Back button.
6. At the GREEN MACHINE, remove the blowout fitting from the Vacuum Pump.



Figure 9-24: Maintenance Screen

9.6.6 Reassemble the Tubes and Valve Components

1. Remove the Solenoid Bases from the Solenoids. Save the Solenoid Bases and Retaining Clips for reuse.
2. Install the Body Gasket, Core Assembly, and Solenoid Base in the Valve Body. (Typical on all 4 Valve Bodies). **See Figure 9-19.**
CAUTION: The Body Gaskets must be clean and apply fresh Petroleum Jelly lubricant.
3. Install the Solenoids on to the Solenoid Bases, then install the Nameplate/Retainers and Retaining Clips.
4. Reinstall the 6 tubes. **See Figures 9-12.**
CAUTION: Do not use any thread sealing compound when assembling the 45° flare nuts.
CAUTION: When tightening the 45° flare nuts: Clamp the tube flare between nut and nose body of the tube by screwing the nut on finger tight. Tighten with a wrench an additional ¼ turn for a metal-to-metal seal.

9.6.7 Conduct a Functionality Test

Conduct a Functionality Test as shown in Chapter 6 of this document.

9.6.8 Ending Stage

1. Lock open the three ball valves between the GREEN MACHINE and the Vent Risers and replace the caps on the three tees.
2. Put the cover on the GREEN MACHINE and screw on the 8 cover screws.
3. Remove the lock(s) and tags from the lockout & tagout.
4. On the Control Panel, tap the home button. The GREEN MACHINE is now operational.

9.7 Leak Test

9.7.1 Purpose of the Leak Test

- The purpose of the Leak Test is to ensure that all the GREEN MACHINE tubing fittings and tubes located inside the GREEN MACHINE are leak free.

9.7.2 Preparation for the Leak Test

1. At the GREEN MACHINE, remove the locks from the three ball valves, close the three valves, and remove a cap from one of the tees. (Only one open tee is required for this test.) **See Figure 9-25.**
2. Make sure the Maintenance Screen is showing on the PLC. **See Figure 9-26 and 9-27.** (The GREEN MACHINE is now in the Manual OFF mode and will not operate.)

If the PLC is not in the Maintenance Screen: At the Main Screen, push the Maintenance Screen button to access the Password Screen, then enter the password to access the Maintenance Screen: 878.

3. Compressed Nitrogen bottle with a regulator is required for the Leak Test.
4. A Leak Test Fixture is required for the Leak Test. **See Figure 9-28.**



Figure 9-26: Maintenance Screen

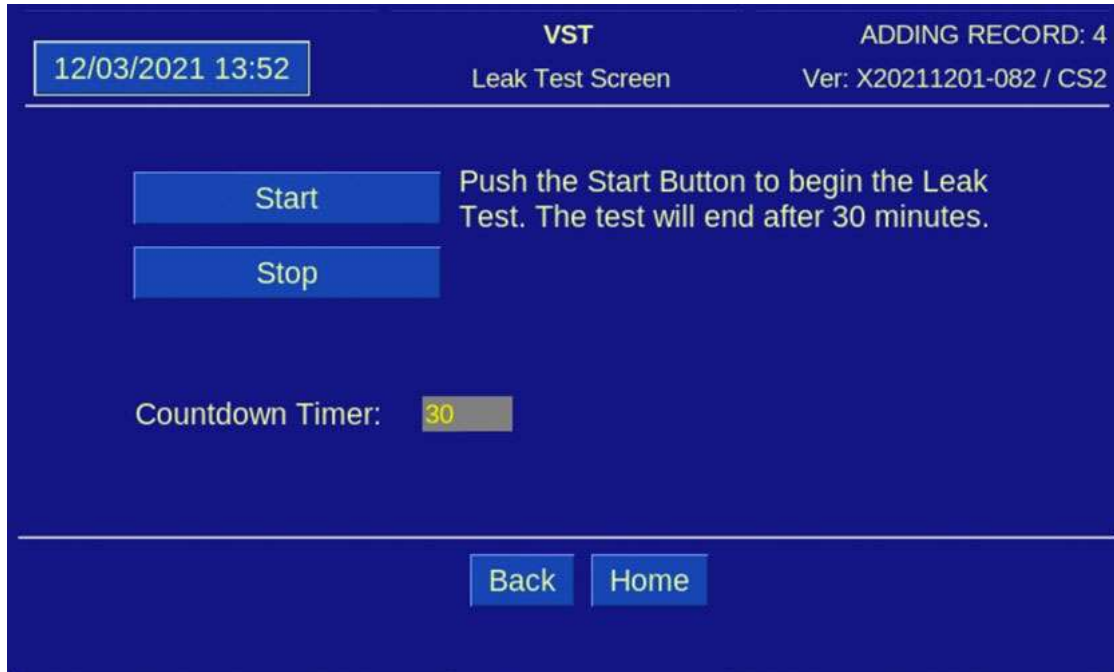

Figure 9-27: Leak Test Screen

Leak Test Procedure, continued...

9.7.3 Leak Test Procedure

1. Install the Leak Test Fixture in any empty 1" pipe tee on the GREEN MACHINE.
See Figures 9-25.
2. The Leak Check is conducted with 1.0-PSI nitrogen.
3. Make sure the isolation valve on the Leak Test Fixture is fully closed.
4. Make sure the Leak Test Fixture pressure regulator is fully closed.
5. Make sure the nitrogen regulator is set to 2.0-PSI outlet pressure.
6. Slowly open the isolation valve on the Leak Test Fixture to provide pressure to the regulator.
7. Slowly open the Leak Test Fixture pressure regulator until the pressure gauge reads 1.0-PSI.

CAUTION: PRESSURIZING THE GREEN MACHINE OVER A MAXIMUM OF 2.0 PSI MAY CAUSE DAMAGE TO THE GREEN MACHINE O-RINGS AND/OR PUMP SEALS, WHICH WILL VOID ALL WARRANTIES OF THE GREEN MACHINE.

8. At the GREEN MACHINE PLC, enter the Maintenance Screen with the password 878. Enter the Test Screen and select Leak Test. **See Figure 9-26 and 9-27.**
 - The Leak Test will continue until one of the following conditions is met:
 - The Stop button is pushed -OR-
 - The GREEN MACHINE PLC internal timer times out at 30 minutes.
9. With the GREEN MACHINE pressurized at 1.0-PSI nitrogen, spray a soapy solution on each fitting to check for bubbles:
 - If bubbles do not appear, the connection is tight.
 - If bubbles do appear, tighten the leaking fitting 1/8" turn (maximum) and re-check for leaks.
 - If the fitting cannot be tightened so that the connection is leak free, replace the 45° flare tube assembly that is leaking with a new tube assembly.
10. Continue this process until all the internal tube fittings have been checked and found leak free.
11. If additional time is needed to conduct the Leak Test, push the Leak Test button again to re-start the 30-minute timer.

Leak Test Procedure, continued...

12. After the Leak Test 30-minute timer expires and the test is complete:
 1. The GREEN MACHINE PLC will show the Maintenance Screen where the GREEN MACHINE is in the Manual OFF mode and will not operate.
 2. Remove the nitrogen from the Leak Test Fixture.
 3. Remove the Leak Test Fixture from the GREEN MACHINE.
 4. Re-install the cap in the tee.
 5. Put the cover back on the GREEN MACHINE and screw on the 8 cover screws.
 6. Open the 3 ball valves at the GREEN MACHINE and place the locks on the valves.
 7. At the GREEN MACHINE PLC, push the home button to return to the Main Screen where the GREEN MACHINE will go into a Normal Operating Mode.

CAUTION: DO NOT PUSH THE HOME BUTTON UNTIL THE BALL VALVES BETWEEN THE GREEN MACHINE AND THE VENT RISERS ARE OPENED. PUSHING THE HOME BUTTON WHEN THE VALVES ARE CLOSED WILL NOT ALLOW THE GREEN MACHINE TO OPERATE PROPERLY AND MAY CAUSE DAMAGE TO INTERNAL COMPONENTS.

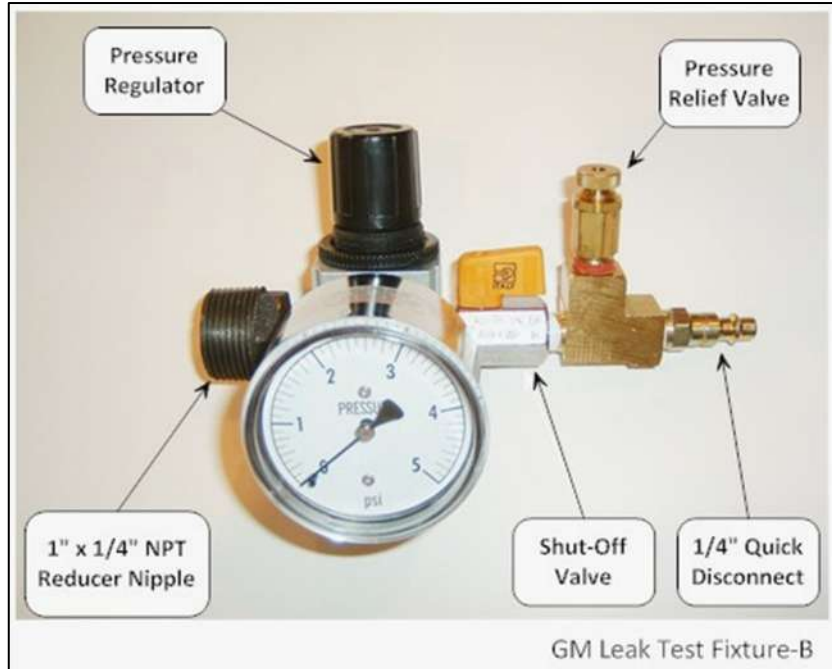

Figure 9-28: Leak Check Fixture



Figure 9-29: GREEN MACHINE leak test

This page left intentionally blank

Appendix A- General Contractor Check-Out Form

The final step in the installation process is to start up the GREEN MACHINE and get it field commission ready.

Before this process can be started, the GREEN MACHINE must be completely and correctly installed, which is why Appendix A was developed.

How to Submit Appendix A:

1. Go to <https://vsthose.com/education-gm3-cs2a-mexico/>
2. Click on "General Contractor."
Note: If you have not been trained to conduct Start-Up or Appendix A, watch the videos under "General Contractor" then go to Step 3.
3. Click on "Appendix A - General Contractor Check Out Form."
4. Fill out and submit Appendix A with the required photos.
5. Receive an email from VST with a copy of the filled-out Appendix A.

The following pages contain the contents of Appendix A and the questions you'll be asked. You may find it helpful to review these pages, so you're prepared for the online questions and requirements.

Once filled out, Appendix A must be submitted by the General Contractor on-line to ensure the GREEN MACHINE is ready for Start-Up.

To be filled out by the General Contractor

Site Information:			
Site Name:			
Site ID:			
Site Street Address:	Site City:	Site State:	Site Zip:

Contractor Information:	
General Contractor (GC) Company:	
GC Phone:	
GC Name:	
GC Email Address:	
GC VST Contractor Cert. #	
Date of Completion:	
GREEN MACHINE Serial Number (SN):	
*the SN can be found on the back side of the junction box inside the GM cover & out the outside of the cover	

Sub- Contractor Information:	
Electrical Contractor (EC) Company:	
EC Name:	
EC VST Contractor Cert. #	
Vapor Piping Contractor (VPC) Company:	
VPC Name:	
VPC VST Contractor Cert. #	

IMPORTANT!!

VST highly recommends going through this check-out form with both the Electrical Contractor and Vapor Piping Contractor so that all steps can be verified to be complete.

STEPS	DESCRIPTION	CHECK AFTER COMPLETION	RESULTS
	Reference Chapter 2 for the Piping Installation:	~	~
1.	Check that all the piping, valves, tees, unions, and riser are installed as shown in Chapter 2, Piping		PIPING IS COMPLETE
2.	Make sure the three valves located at the GREEN MACHINE are locked in the Open position.		ISOLATION VALVES ARE LOCKED OPEN
3.	Make sure the piping connected to the GREEN MACHINE slopes a minimum of ¼" per foot towards the vent risers, and that there are no traps.		PIPING SLOPE AND TRAPS
4.	Make sure the ¼" drain line is installed correctly between the vapor inlet and vapor return.		¼" DRAIN LINE IS INSTALLED
	Reference Chapter 3 for the Electrical Installation:	~	~
5.	Check that all the electrical connections are complete, correct, and tight at the VST Control Panel and at the GREEN MACHINE Internal Junction Box.		ELECTRICAL IS COMPLETE
6.	Turn the GREEN MACHINE breaker ON at the Main Distribution Panel.		MAIN POWER IS ON
7.	Check that the VST Control Panel wiring is connected to the station Emergency Shut-OFF (ESO) switch.		ESO IS CHECKED
8.	Check that the VST Control Panel wiring is connected to the Fuel Management System Overfill Alarm.		OVERFILL IS CHECKED

All items have been checked and verified:

_____ Name

_____ Date

POST-INSTALLATION GREEN MACHINE™ CHECK-OUT:

- Upon completion, the General Contractor must submit this signed and dated form on-line to VST.
- After the form is complete, Click the Submit button at the end of the form.

This page left intentionally blank

Appendix B- Start-Up Contractor Check-Out Form

The final step in the installation process is to start up the GREEN MACHINE and get it field commission ready.

This final commissioning process requires a Verification Code that will be entered into the PLC.

How to Submit Appendix B and get a Verification Code:

1. Go to <https://vsthose.com/education-gm3-cs2a-mexico/>

2. Click on “Start-Up Contractor.”

Note: If you have not been trained to conduct Start-Up or Appendix B, watch the videos under “Start-Up Contractor” then go to Step 3.

3. Click on “Appendix B - Start-Up Contractor Check Out Form.”

4. Fill out and submit Appendix B with the required photos.

5. Receive an email from VST with the Verification Code and a copy of the filled-out Appendix B.

The following pages contain the contents of Appendix B and the questions you’ll be asked. You may find it helpful to review these pages, so you’re prepared for the online questions and requirements.

Appendix B must be used with Chapter 6: Testing & Start-Up Procedures.

Once filled out, Appendix B must be submitted by the Start-Up Contractor on-line to ensure the GREEN MACHINE becomes operational.

To be filled out by the Start-Up Contractor

SITE INFORMATION:

Site: *

Site ID:

Site Address:

Station Phone:

START-UP CONTRACTOR INFORMATION:

Start-Up Contractor Company: *

Start-Up Contractor Phone: *

Start-Up Contractor's Name: *

Email Address: *

NOTE: This is the e-mail address that the Start-Up Verification Code will be sent. Make sure you have immediate access to your e-mail listed above to complete the Start-Up. If the code cannot be received, the GREEN MACHINE CAN NOT become operational.

Start-Up Date of Completion: *

**GREEN MACHINE
Serial Number:** *

The Serial Number (SN) can be found on the back side of the junction box
Note: inside the GREEN MACHINE cover, and on the outside of the cover.

The following readings must be filled out. This information is to make sure the VST Control Panel is reading the correct information and that the underground storage tanks are below the Overfill Alarm Level of 90%.

Record the Reading from the PLC:	
UST Pressure Reading (IWC):	
Run-Cycles Reading (No.):	

Underground Storage Tanks Levels Readings and Calculations	
If a UST tank level exceeds 90%, and the Overfill Alarm is installed, the GREEN MACHINE will not operate. The tank information entered below will calculate the tank levels (%). Obtain and fill in the volumes and ullages from the Fuel Management System in order to calculate the tank levels.	
Tank 1 Volume (Gal.) *	
Tank 1 Ullage (Gal.) *	
Tank 1 Level (%) Calculated	
Tank 2 Volume (Gal.) *	
Tank 2 Ullage (Gal.) *	
Tank 2 Level (%) Calculated	
Tank 3 Volume (Gal.) *	
Tank 3 Ullage (Gal.) *	
Tank 3 Level (%) Calculated	
Tank Other Volume (Gal.) *	
Tank Other Ullage (Gal.) *	
Tank Other Level (%) Calculated	

STEPS	DESCRIPTION	CHECK AFTER COMPETION	RESULTS
1.	<ul style="list-style-type: none"> • Functionality Test 		
2.	<ul style="list-style-type: none"> • Overfill Alarm Connection Test 		
3.	<ul style="list-style-type: none"> • Change the Date and Time Procedure 		
4.	All 3 plugs are installed in the 3 tees at the GREEN MACHINE.		INSTALL THE TEE PLUGS
5.	Make sure the 3 ball valves at the GREEN MACHINE are locked in the OPEN position.		OPEN THE ISOLATION VALVES
6.	Secure the GREEN MACHINE cover on the GREEN MACHINE.		INSTALL THE COVER
7.	Push the Alarms Screen to make sure there are no active alarms and all the Alarm boxes are Normal (Green). Push the Home button to return to the Main Screen. If there is an Alarm, see the Operator Instruction Sheet for directions.		CHECK THE ALARMS

GREEN MACHINE Start-Up Form, continued...

STEPS	DESCRIPTION	CHECK AFTER COMPETION	ITEM CHECKED
8.	Below are the required pictures to be submitted with Appendix B:		
11.1	Picture of the entire vent riser.		Pictures to Up-Load
11.2	Picture of the vapor piping at the GREEN MACHINE showing the ¼" diameter copper drain line.		
11.3	Picture of the valves locked in the open position.		
11.4	Picture of the VST Control Panel PLC Main Screen.		
11.5	Picture inside the VST Control Panel, inside the front door.		
11.6	Picture inside the VST Control Panel, inside the panel.		
11.7	Picture inside the VST Control Panel, showing the field wiring connections.		
CAUTION: The locking ball valve handles at the GREEN MACHINE inlet, return, and outlet must <u>not</u> be removed.			

All items have been checked and verified:

_____ Name (Print)

_____ Date

GREEN MACHINE START-UP CHECK-OUT:

- Upon completion, the Start-Up Contractor must submit this signed and dated form on-line to VST.
- After the form is complete, Click the Submit button at the end of the form.