

Executive Order VR-202-AA
Assist Phase II EVR System
Including In-Station Diagnostic (ISD) Systems

Exhibit 9
VEEDER-ROOT ISD OPERABILITY TEST PROCEDURE

The following procedures shall be used at field sites to determine the operability of the Veeder-Root ISD system to satisfy the requirements documented in VAPOR RECOVERY CERTIFICATION PROCEDURE, CP-201, CERTIFICATION PROCEDURE FOR VAPOR RECOVERY SYSTEMS AT GASOLINE DISPENSING FACILITIES.

Testing the ISD equipment in accordance with this procedure will verify the equipment's operability for Vapor Containment Monitoring and Vapor Collection Monitoring.

Veeder-Root's TLS console ISD System Self-Test Monitoring algorithms are designed to verify proper selection, setup and operation of the TLS console modules and sensors and will not complete and report passing test results in the event of a failure of components used in the system. Completed ISD monitoring tests are evidence that:

- The system was properly powered for data collection
- All necessary ISD sensors were setup and connected
- All necessary ISD sensors were operating within specification
- All internal components including TLS console modules were properly setup and operating within specification

Veeder-Root recommends printing a copy of the ISD ALARM STATUS and ISD DAILY report (REF. Section 5, Operation of the ISD Install, Setup & Operation Manual) periodically to determine that compliance tests are being completed in accordance with local and state regulations.

A step-by-step worksheet for recording data from the following operability tests is provided at the end of this Exhibit.

Note that districts may require use of an alternate form to meet these requirements, provided the alternate form includes the same minimum parameters.

Veeder Root ISD Operability Testing

Definitions common to all certification and test procedures are in:

D-200 Definition for Vapor Recovery Procedures

For the purpose of this procedure, the term "CARB" refers to the California Air Resources Board, and the term, "CARB Executive Officer" refers to the Executive Officer of the CARB or his or her authorized representative or designee.

Vapor Pressure Sensor Verification Test

1. Purpose and Applicability

- 1.1. The purpose of this test procedure is to determine if the Veeder-Root Vapor Pressure Sensor (listed in Exhibit 1) is operating in accordance with the pressure sensor requirements of Exhibit 2. This procedure is used:
 - 1.1.1. To determine the measured ullage pressure in underground gasoline storage tanks (UST) installed at gasoline dispensing facilities (GDFs) equipped with a Assist Phase II enhanced vapor recovery system with ISD and compare to the Veeder-Root Vapor Pressure Sensor (Vapor Pressure Sensor) reading at the TLS console.
 - 1.1.2. To determine whether the Vapor Pressure Sensor complies with the performance specification when the sensor is exposed to ambient pressure.
- 1.2. This procedure is applicable for compliance testing.

2. Principle and Summary of Test Procedure

- 2.1. Determining UST Pressure - If the Vapor Pressure Sensor is installed on the vapor return line of a dispenser closest to the USTs, the pressure of the UST is determined at the Phase I vapor recovery adaptor (dry break assembly) with a vapor coupler test assembly as shown in Figures 2 and 3 of TP-201.3 (*Determination of 2 Inch WC Static Pressure Performance of Vapor Recovery Systems of Dispensing Facilities*) or a modified dust cap test assembly as shown in Figures 9-1 and 9-2 of this exhibit. The modified dust cap test assembly is equipped with a center probe, which opens the dry break, and a quick connect fitting that is connected to an electronic pressure measuring device or digital manometer. The modified dust cap test assembly should open the dry break with minimal venting of the UST. This test can be performed while product is being dispensed into motor vehicles.

If the Vapor Pressure Sensor is installed on the vent stack, the pressure of the USTs is determined at the vent stack test port as shown in Figure 9-5. The vent stack test port is equipped with a quick connect fitting that is connected to an electronic pressure measuring device or digital manometer. This test can be performed while product is being dispensed into motor vehicles.

- 2.2. Determining Ambient Pressure - The Vapor Pressure Sensor is subjected to ambient pressure by turning the Vapor Pressure Sensor valve, which is located on the vent stack or in the dispenser closest to the tanks, to the atmospheric valve position as shown in Figure 9-3. This test can be performed while product is being dispensed into motor vehicles.

3. Biases and Interferences

- 3.1. This test shall not be conducted within 30 minutes following gasoline transfer from a cargo tank.
- 3.2. The range of the Vapor Pressure Sensor is between positive five (+5.0) and negative five (-5.0) inches water column. If the headspace of the underground storage tank is under a vacuum of greater than negative five inches water column (i.e. -6, -7, -8 etc.), the results of section 8.4 could be biased toward non compliance. Under such condition, the vacuum level should be relieved to a value between negative five and negative two inches water column by depressing the poppet of the Phase I vapor adaptor return poppet. Once an adequate amount of air has been ingested into the headspace, the remaining vacuum must be allowed to stabilize for a minimum of fifteen (15) minutes before taking a reading.
- 3.3. If the Vapor Pressure Sensor is located at the vapor return line of the dispenser, the UST pressure must be determined at the Phase I vapor adaptor as shown in Figure 9-1 and 9-2 of this exhibit.
- 3.4. If the Vapor Pressure Sensor is located at the vent stack, the UST pressure must be determined at the vent stack test port as shown in Figure 9-5.
- 3.5. If Veeder-Root's "Maintenance Tracker" is installed and enabled, access to the "diagnostic mode" and "set-up mode" of the TLS Console is prohibited unless a Maintenance Tracker Technician Key or personal computer equipped with Veeder-Root's ISD Setup Tool Software Version 1.09 or higher is made available. Maintenance Tracker is an optional security device designed to prevent unauthorized tampering and clearing of Veeder-Root tank monitoring and ISD alarms. Maintenance Tracker resides within the TLS console and when enabled, a message will appear on the two line display of the TLS console. For additional instructions on how to access the desired parameters to complete this test procedure, see Exhibit 12; "Veeder-Root Maintenance Tracker (Optional)".

- 3.6. The vapor pressure sensor value observed at the TLS console is refreshed at the frequency defined in Table 9-1. Prior to the simultaneously recording the values observed at the digital manometer and the TLS console, the technician should wait until the value the TLS console is refreshed.

TABLE 9-1
Vapor Pressure Sensor Refresh Rate

Veeder-Root Vapor Pressure Sensor	TLS Console Refresh Rate
Wired	~10 seconds
Wireless	~60 seconds

4. Range and Accuracy

- 4.1. A digital (electronic) manometer with 0.01 inches WC, or better, resolution. The sensor must have a minimum measuring range of +/- 10 inches WC. The sensor must be accurate to 0.05 inches WC for any pressure measurement made during the prescribed tests. For a manometer with a +/- 10 inches WC measurement range, this requires a 0.25% full scale accuracy assuming a 20 inch full scale range (i.e. -10 to +10).

5. Equipment

- 5.1. The Vapor Pressure Sensor is located at the vapor return line of the dispenser closest to the USTs, the vapor adapter dust cap test assembly shall be modified in the following manner:
- 5.1.1. Install a probe in the center of the dust cap as shown in Figure 9-1 (one method is to tap and thread probe). The probe shall be of sufficient length to open approximately 1/2 inch of the dry break while allowing the cap to maintain a leak tight seal on the adaptor.
- 5.1.2. Install female quick connect fitting on the top of the dust cap, offset from the center probe as shown in Figure 9-1. A Swagelok, part number SS-QC4-B-4-PM, quick connect fitting or equivalent can be used.
- 5.1.3. Use "Tygon tubing" or equivalent to connect the manometer to the

dust cap (Figure 9-2). Install a male quick connect fitting (Swagelok part number SS-QC4-5-400 or equivalent can be used) on one end of a ferrule stainless steel tube (or equivalent material). Connect one end of the "Tygon tubing" to the stainless steel tube and connect the other end to the digital manometer (see Figure 9-2).

- 5.2. Alternatively, the vapor coupler test assembly, Figures 2 and 3 of TP-201.3 may be used in lieu of the dust cap test assembly.
- 5.3. If the Vapor Pressure Sensor is installed at the vent stack, the following test assembly is required:
 - 5.3.1. A test port and female quick connect fitting shall be installed on the plumbing fixture below the Vapor Pressure Sensor enclosure as shown in Figure 9-5. A Swagelok, part number SS-QC4-PM, quick connect fitting or equivalent can be used.
 - 5.3.2. Use "Tygon tubing" or equivalent to connect the manometer to the test port (Figure 9-2). Install a male quick connect fitting (Swagelok part number SS QC4-5-400 or equivalent can be used) on one end of a ferrule stainless steel tube (or equivalent material). Connect one end of the "Tygon tubing" to the stainless steel tube and connect the other end to the digital manometer (see Figure 9-2).
 - 5.3.3. Various pipe fittings to accommodate ¼ inch test port, including half inch NPT female tee fitting and half inch to quarter inch reducer, as shown in figure 9-5.
- 5.4. Digital Manometer (Electronic Pressure Measuring Device)

See the requirements of Section 4.1 above.

6. Calibration Requirements

- 6.1. A copy of the most current calibration of the electronic pressure measuring device shall be kept with the equipment.
- 6.2. All electronic pressure measuring devices shall be bench tested for accuracy using a reference gauge, incline manometer or National Institute of Standards and Technology (NIST) traceable standard at least once every twelve (12) consecutive months. Accuracy checks shall be performed at a minimum of five (5) points (e.g., 10, 25, 50, 75 and 90 percent of full scale) each for both positive and negative pressure readings. Accuracy shall meet the requirements of Section 4.

7. Determining UST Pressure

7.1. Pre-Test Procedure

- 7.1.1. Turn on digital manometer and allow instrument to warm up for five minutes.
- 7.1.2. Zero out digital manometer using adjustment pod on top of instrument in accordance with manufacturer's instructions. Drift may be minimized by re-zeroing immediately after use by venting both pressure ports to atmosphere until the display reads exactly zero.
- 7.1.3. If the Vapor Pressure Sensor is located at the vapor return line of the dispenser, attach the male quick connect fitting to the female quick connect fitting on the modified dust cap test assembly (see Figure 9-2).
- 7.1.4. If the Vapor Pressure Sensor is located at the vent stack, attach the male quick connect fitting to the female quick connect fitting on the vent stack test port (see Figure 9-5).
- 7.1.5. Attach digital manometer to open end of Tygon tubing.
- 7.1.6. If the Vapor Pressure Sensor is installed at the vapor return line of the dispenser, attach the dust cap or vapor coupler test assembly to the Phase I vapor adaptor (see Figure 9-2).

7.2. Test Procedure

- 7.2.1. If the headspace of the underground storage tank is under a vacuum of greater than negative five (-5) inches water column (i.e. -6, -7, -8, etc.), the vacuum should be relieved to a value between negative five and negative two inches water as described in Section 3.2 above.
- 7.2.2. On the TLS Console front panel, use the 'mode key' to scroll to "DIAG MODE" then use the function and step keys, as show in Figure 9-4 to view the current pressure value.
- 7.2.3. Simultaneously record the ullage pressure value from the digital manometer and the TLS Console. Record the above information on Form 1 "Data Form for Vapor Pressure Sensor UST Pressure Test." Districts may require the use of an alternate form, provided it includes the same minimum parameters as identified in the Data Form.

NOTE: The vapor pressure sensor value observed at the TLS console is refreshed at the frequency defined in Table 9-1. Prior to simultaneously recording the values observed at the digital manometer and the TLS console, the technician should wait until the value at the TLS console is refreshed.

7.2.4. Verify that the pressure reading from the TLS Console is within ± 0.2 inches WC from the digital manometer reading. If difference is not within ± 0.2 inches WC, the pressure sensor is not in compliance with the pressure sensor requirements of Exhibit 2.

7.2.5. Press the <MODE> key to leave the 'CALIBRATE SMARTSENSOR' menu. Note: Do not calibrate the sensor!

8. Determining Ambient Pressure

8.1. Test Procedure for Testing Sensor Under Ambient Pressure

8.1.1. Access the Vapor Pressure Sensor, which is located on the vent stack or in the dispenser closest to the tanks. Record pressure sensor location and serial number on the data form.

8.1.2. Remove the cap from the ambient reference port of the Vapor Pressure Sensor valve and open the valve to atmosphere by turning it 90 degrees so that the flow arrows point to both the Vapor Pressure Sensor sensing port and the ambient reference port (see Figure 9-3).

8.1.3. On the TLS Console front panel, use the 'mode key' to scroll to "DIAG MODE" then use the function and step keys, as shown in Figure 9-4 to view the current pressure value.

8.1.4. Note: The vapor pressure sensor value observed at the TLS console is refreshed at the frequency defined in Table 9-1. Prior to simultaneously recording the values observed at the digital manometer and the TLS console, the technician should wait until the value at the TLS console is refreshed.

8.1.5. Verify that the pressure value is between +0.2 and -0.2 inches WC. If the pressure value is not within this range, the pressure sensor is not in compliance with the pressure sensor requirements of Exhibit 2.

8.1.6. Replace the cap on the ambient reference port of the Vapor Pressure Sensor valve. Restore the Vapor Pressure Sensor valve by turning it 90 degrees so that the flow arrows point to both the Vapor Pressure Sensor sensing port and the UST vapor space sensing line (see. Figure 9-3).

- 8.1.7. Press the <MODE> key to leave the 'CALIBRATE SMARTSENSOR' menu. Note: Do not calibrate the sensor!
- 8.1.8. Record the above information on Form 2 "Data Form for Vapor Pressure Sensor Ambient Reference Test." Districts may require the use of an alternate form, provided it includes the same minimum parameters as identified in the Data Form.

9. Alternate Procedures

- 9.1. This procedure shall be conducted as specified. Any modifications to this test procedure shall not be used unless prior written approval has been obtained from the CARB Executive Officer, pursuant to Section 14 of CP-201.

FIGURE 9-1
Typical Modified Vapor Adaptor Dust Cap (Bottom View)

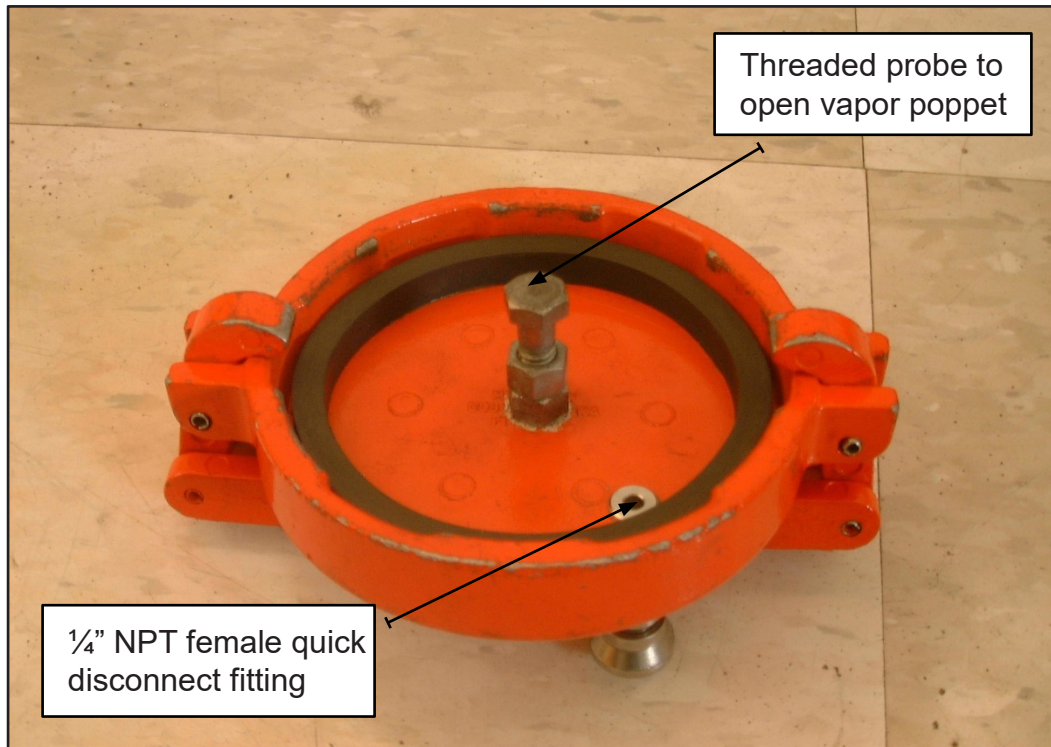

FIGURE 9-2
Typical Field Installation of UST Pressure Measurement Assembly

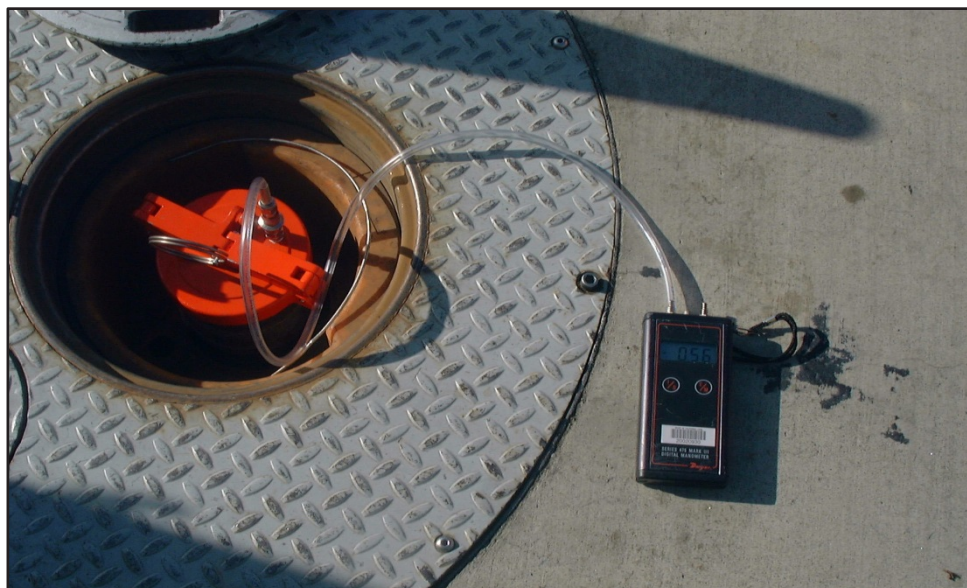

FIGURE 9-3
Vapor Pressure Sensor Valve Position

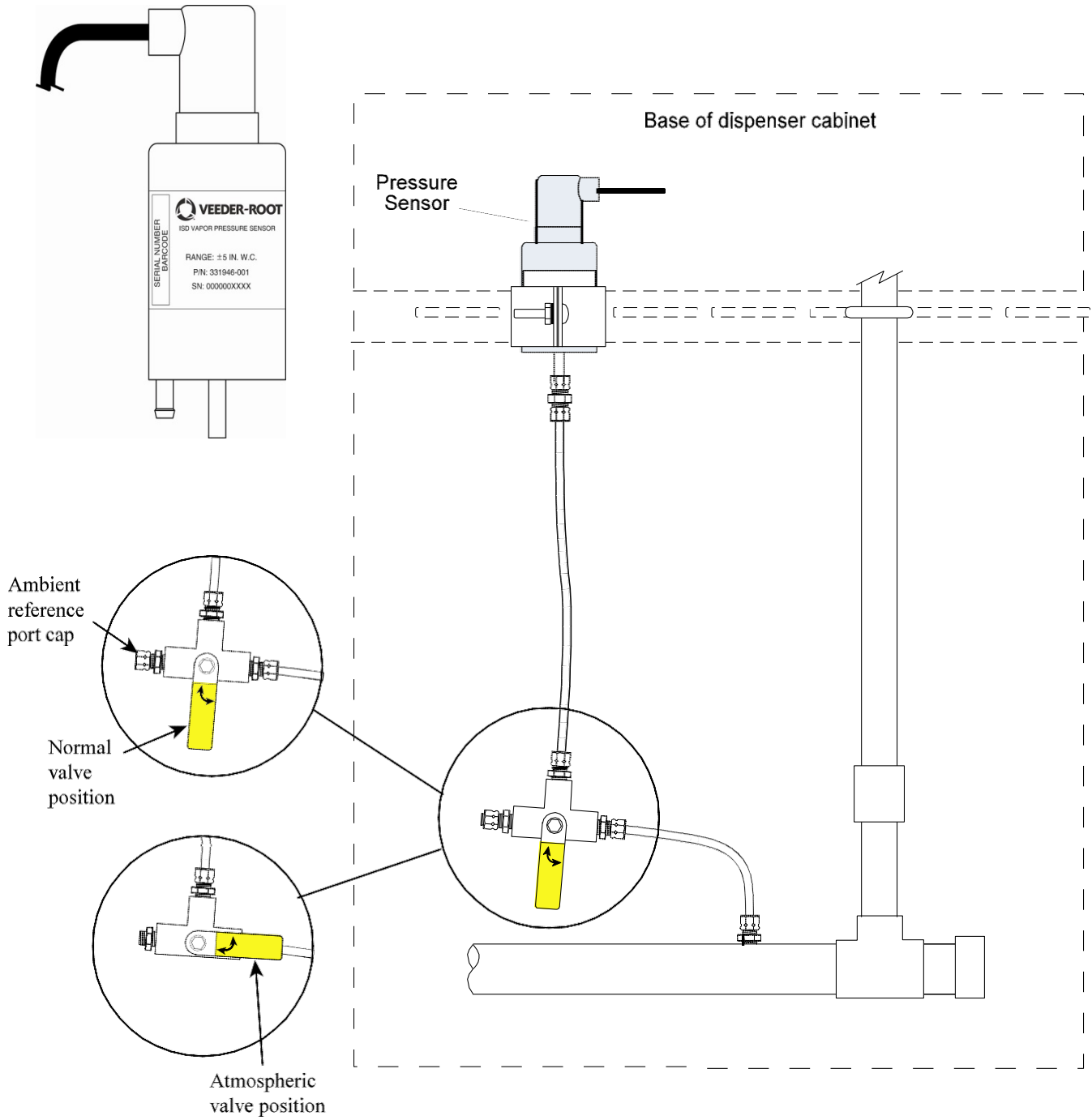

FIGURE 9-4
 Accessing Calibrate SmartSensor Diagnostic Menu
 for Vapor Pressure Sensor Reading

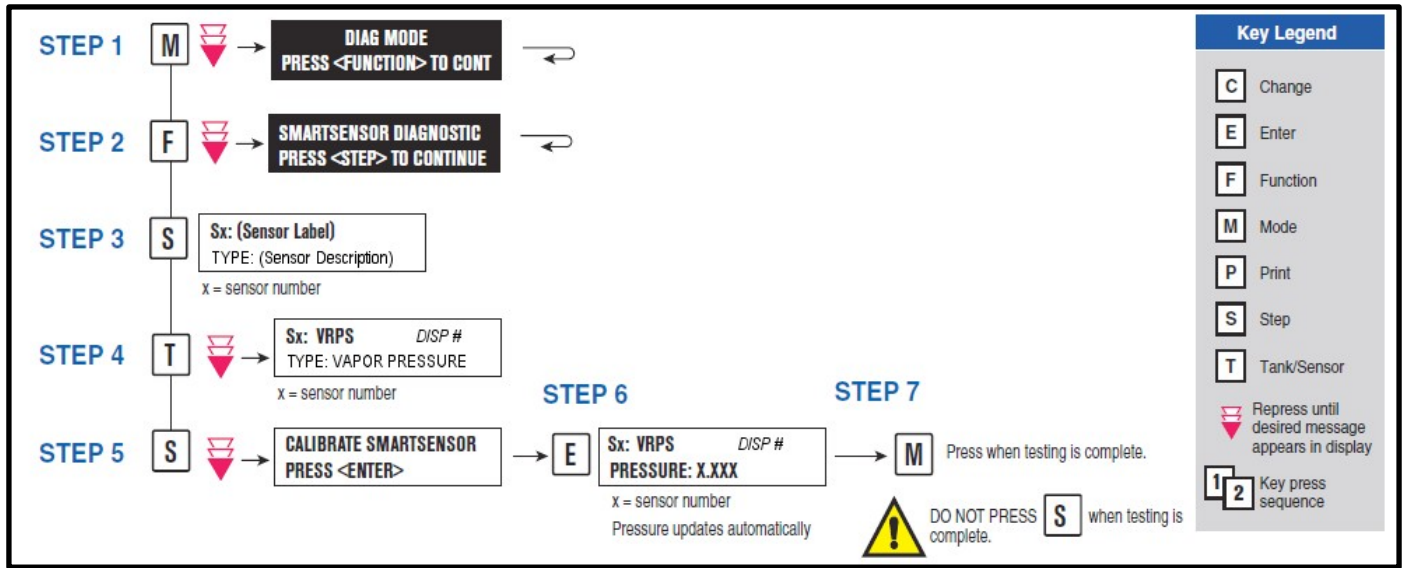
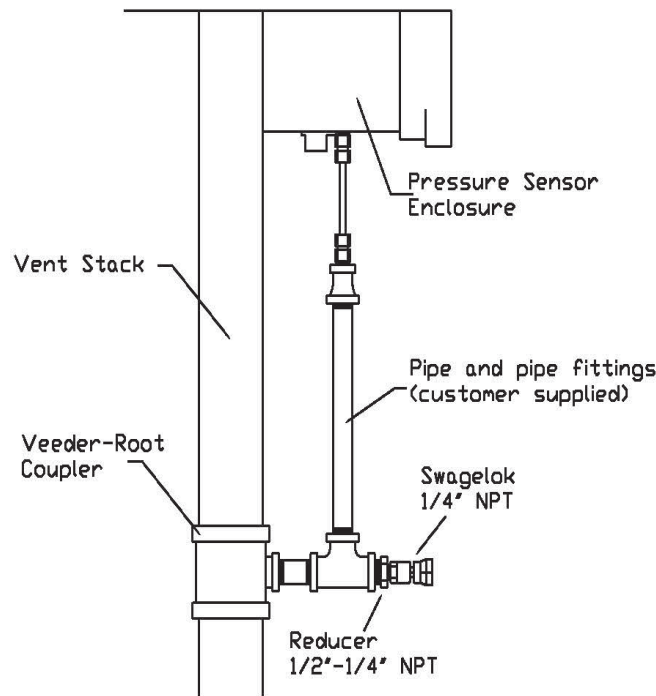

FIGURE 9-5
 Vapor Pressure Sensor Vent Stack Test Port Configuration



FORM 2

Data Form for Vapor Pressure Sensor Ambient Reference Test

DATE OF TEST: _____

SERVICE COMPANY NAME	SERVICE COMPANY'S TELEPHONE
SERVICE TECHNICIAN	VEEDER-ROOT TECH CERTIFICATION # (as applicable)
	ICC or DISTRICT TRAINING CERTIFICATION (as applicable)
STATION NAME	DISTRICT PERMIT #
STATION ADDRESS	CITY STATE ZIP

PRESSURE SENSOR LOCATION: FP # _____ <input type="checkbox"/> DISPENSER FUELING POINT (FP) VENT STACK <input type="checkbox"/> or VENT STACK	PRESSURE SENSOR SERIAL NUMBER: _____
--	---

STEP 7.1.2	REFERENCE PORT CAP REMOVED? <input type="checkbox"/> VALVE SET TO AMBIENT REFERENCE PORT (PER FIG. 9-3)? <input type="checkbox"/>
STEP 7.1.3	NON-CALIBRATED SENSOR VALUE _____ Inches WC (OBTAIN VALUE USING TLS CONSOLE KEYPAD SEQUENCE SHOWN IN FIG. 9-4, CALI- BRATE SMARTSENSOR)
STEP 7.1.4	PRESSURE BETWEEN +0.20 & -0.20? <input type="checkbox"/> Yes <input type="checkbox"/> No IF NO: THE PRESSURE SENSOR IS NOT IN COMPLIANCE WITH THE PRESSURE SEN- SOR REQUIREMENTS OF EXHIBIT 2.
STEP 7.1.5	REFERENCE PORT CAP REPLACED? <input type="checkbox"/> VALVE SET TO NORMAL VALVE POSITION (PER FIG 9-3)? <input type="checkbox"/>
STEP 7.1.6	MODE KEY PRESSED TO EXIT THE CALIBRATE SMARTSENSOR MENU? <input type="checkbox"/>

Vapor Flow Meter Operability Test

Note: When conducting an Assist EVR Phase II system V/L test per Exhibit 5, 4.5 to 5 gallons shall be dispensed.

1. Connect a notebook PC – See figure 5-9 of the ISD Install, Setup & Operation Manual. Run Veeder-Root's "ISD PC Setup Tool", v1.10 or higher, to the dedicated TLS serial port that is required for ISD reports access. Using the tool, access the individual fueling point "dispensing event ISD A/L" results as needed in this test procedure. These results are compared to the manually measured V/L's in the procedure. Training on use of the tool is provided as part of the Veeder-Root training program for ISD. A trained service technician must be present when performing this operation.
2. Select a dispenser and note the fueling point numbers on the data form. Obtain the vapor flow meter serial number (available from the EVR/ISD Setup Printout – see Figure 3-6 in the ISD Install, Setup & Operation Manual). Record the serial number on the data form.
3. Conduct a Assist EVR Phase II system V/L test per Exhibit 5 of VR-202 dispensing between 4.5 to 5 gallons with lowest grade fuel available on that dispenser to obtain a V/L result.
4. Obtain the corresponding ISD A/L value for that V/L test obtained from the TLS using the "ISD PC Setup Tool".
5. Compare the ISD A/L value for that dispenser hose to the V/L result (subtract V/L result from A/L value and note difference on the form).
6. Pass: If the difference is between -0.15 and +0.15, then the ISD A/L value is within +/- 0.15 of the V/L result. Circle "Pass" to document that the ISD flow meter in that dispenser passes and repeat the procedure beginning at Step 2 for the next dispenser.
7. Continue: If the ISD A/L value is NOT within +/- 0.15 of the V/L result, then go to Step 6.
8. Run two more V/L tests per Exhibit 5 of VR-202 dispensing between 4.5 to 5 gallons with lowest grade fuel on the same hose and average the two results with the first V/L result from Step 3.
9. Obtain the corresponding two ISD A/L values from the TLS and average the two values with the first ISD A/L value from Step 4.
10. Compare the average of the 3 ISD values for that hose to the average of the 3 V/L results (subtract V/L average from A/L average and note difference on the form).

11. Pass: If the ISD A/L average is within +/- 0.15 of the average of the 3 V/L results, the ISD flow meter in that dispenser passes the operability test. Go to the next dispenser and repeat the procedure beginning at Step 2.
12. Continue: If the ISD A/L average is NOT within +/- 0.15 of the average of the 3 V/L test results, then go to Step 9.
13. If a second fueling position is available on the dispenser, repeat the tests beginning at Step 3 for the second fueling position. If the second fueling position tests do not pass Steps 3 through 8, then the flow meter is not in compliance with the requirements of Exhibit 2.

Site Shutdown Test

1. This test must be performed by a certified Veeder-Root contractor.
 - 1.1. Remove power from TLS console.
 - 1.2. Confirm power to submersible pumps is off by verifying that gasoline dispensing has been disabled.
 - 1.3. Restore power to TLS console.

Veeder-Root In-Station Diagnostics (ISD)

Vapor Flow Meter Operability Test Procedure

(Page 1)

DATE OF TEST: _____

SERVICE COMPANY NAME	SERVICE COMPANY'S TELEPHONE		
SERVICE TECHNICIAN	VEEDER-ROOT TECH CERTIFICATION #		
STATION NAME	DISTRICT PERMIT #		
STATION ADDRESS	CITY	STATE	ZIP

STEP 2.	VAPOR FLOW METER SERIAL NUMBER _____		
	DISPENSER FUELING POINT NUMBERS FP _____ FP _____		
STEP 3.	LOW GRADE FUEL HOSE *V/L RESULT #1 (ONE FP ONLY)		
STEP 4.	ISD A/L VALUE #1 CORRESPONDING TO RESULT IN STEP 3		
STEP 5.	STEP 4. VALUE MINUS STEP 3. VALUE	DIFF.	DIFF.
	PASS IF DIFFERENCE IS WITHIN +/-0.15, IF LARGER DIFFERENCE, THEN CONTIN- UE TO STEP 6 (CIRCLE ONE)	PASS CONTINUE TO STEP 6	PASS CONTINUE TO STEP 6
STEP 6.	LOW GRADE FUEL HOSE V/L RESULT #2		
	LOW GRADE FUEL HOSE V/L RESULT #3		
	AVERAGE OF 3 V/L RESULTS	AVG.	AVG.
STEP 7.	ISD A/L VALUE #2		
	ISD A/L VALUE #3		
	AVERAGE OF 3 A/L VALUES	AVG.	AVG.

Veeder-Root In-Station Diagnostics (ISD)

Vapor Flow Meter Operability Test Procedure **(Page 2)**

DATE OF TEST: _____

	STEP 7. AVG MINUS STEP 6. AVG.	DIFF.	DIFF.
STEP 8.	PASS IF DIFFERENCE IS WITHIN +/-0.15, IF LARGER DIFFERENCE, THEN CONTINUE TO STEP 9.	PASS CONTINUE TO STEP 9	
STEP 9.	IF CONTINUE, REPEAT AT STEP 3. FOR 2 ND FP USING 2 ND FP COLUMN, ABOVE.		

*Measure V/L using test procedure in Exhibit 5 of VR-202 dispensing between 4.5 to 5 gallons.

Veeder-Root In-Station Diagnostics (ISD)

Site Shutdown Test

DATE OF TEST: _____

SERVICE COMPANY NAME	SERVICE COMPANY'S TELEPHONE
SERVICE TECHNICIAN	VEEDER-ROOT TECH CERTIFICATION #
STATION NAME	DISTRICT PERMIT #
STATION ADDRESS	CITY STATE ZIP

STEP 1.	POWER REMOVED FROM TLS CONSOLE?
STEP 2.	POWER TO SUBMERSIBLE PUMPS REMOVED BY TLS? (VERIFY GASOLINE FUELING DISABLED)
STEP 3.	POWER RESTORED TO TLS CONSOLE?

COMMENTS (INCLUDE DESCRIPTION OF REPAIRS MADE)