

FIGURE 8-1
Configuration of Healy Clean Air Separator to Conduct TP-201.3

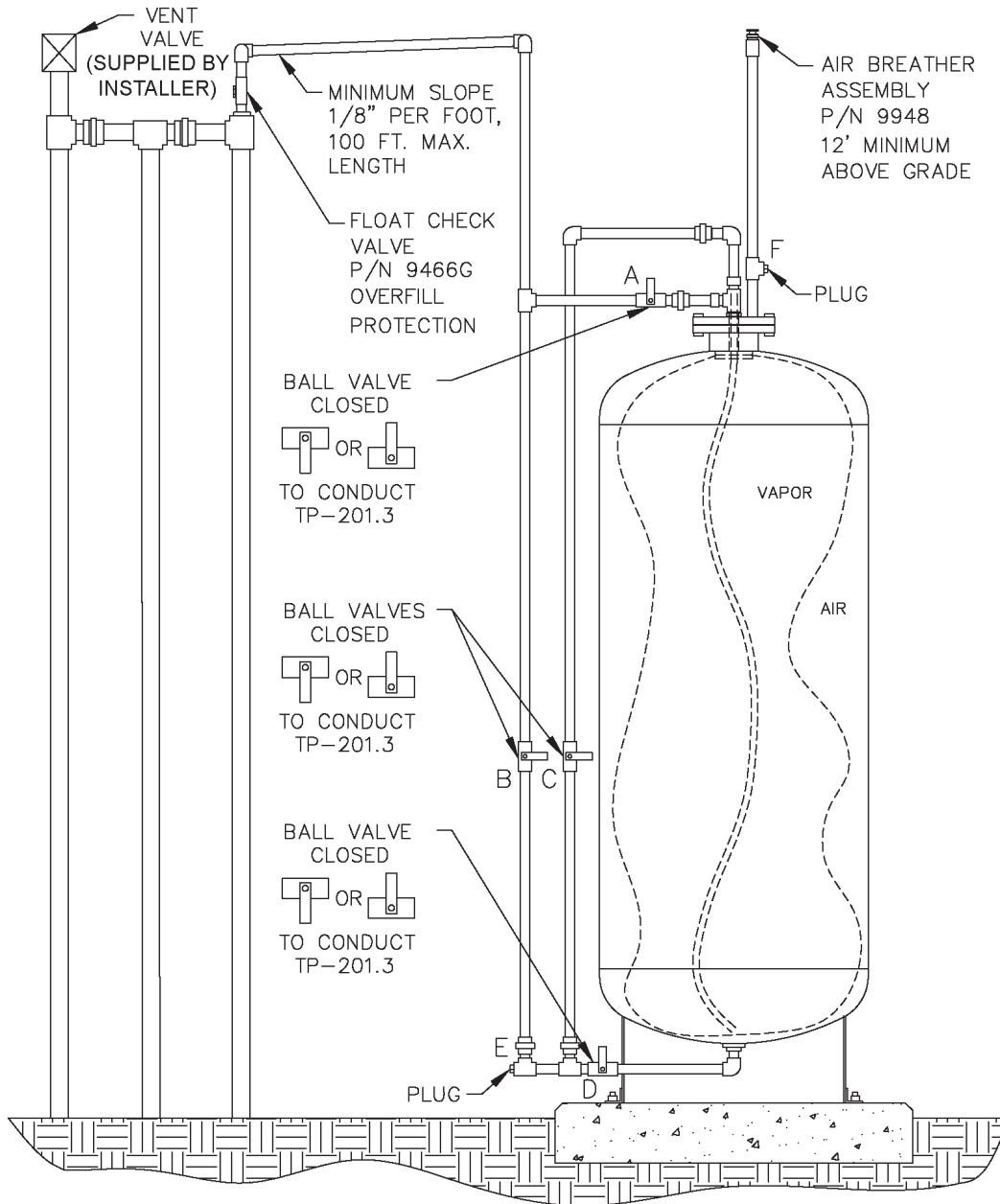
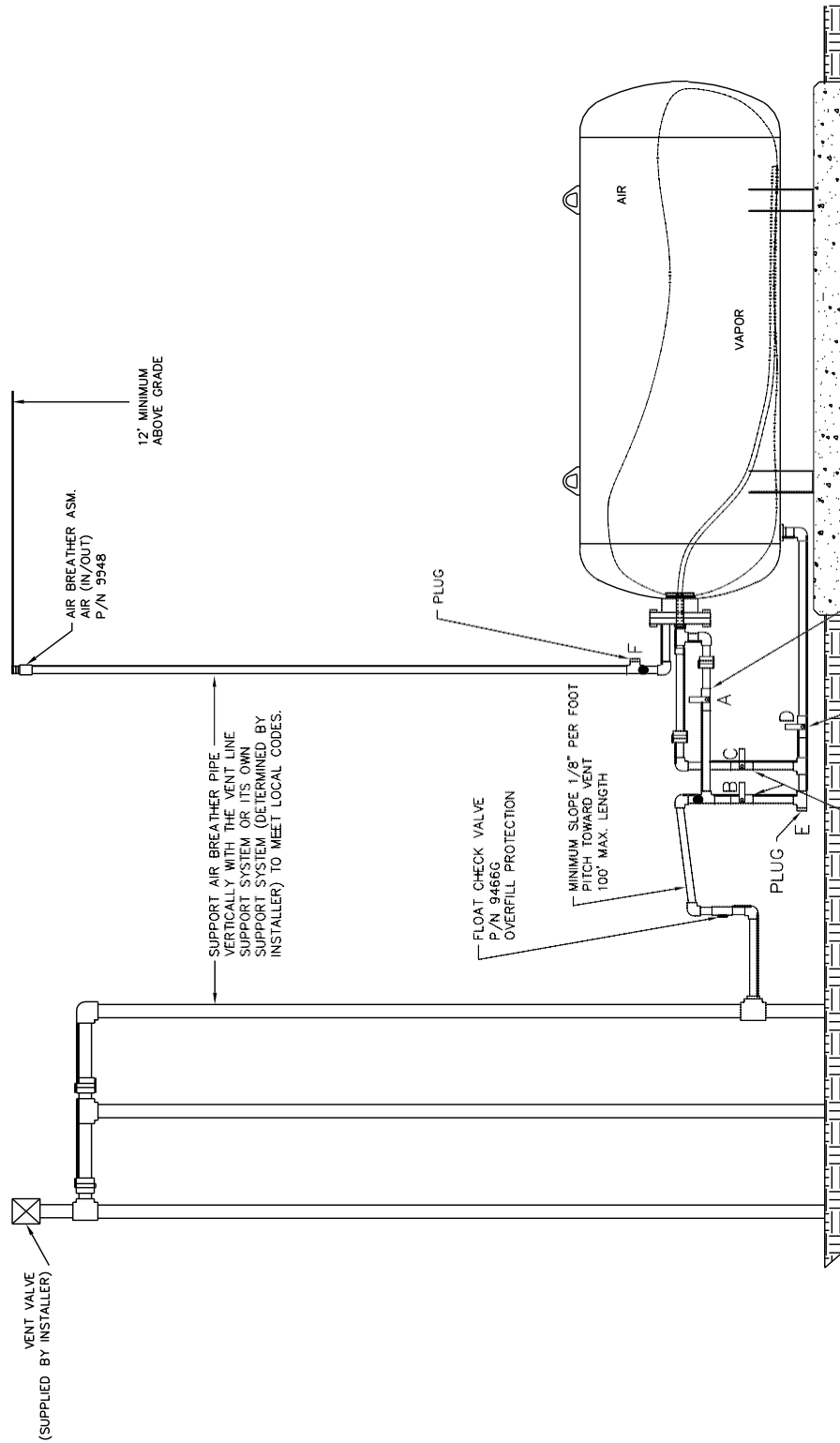

FIGURE 8-1H
Configuration of Healy Clean Air Separator to Conduct TP-201.3



PART B - REQUIRED ITEMS IN CONDUCTING TP-201.3 FOR PERMEATOR INSTALLATIONS

The instructions below are required when conducting TP-201.3 for these systems. The tester shall document that each step was followed as indicated below and shall include this page of the Exhibit with the submission of TP-201.3 test results. Note that districts may require use of an alternate form to meet these requirements, provided the alternate form includes the same minimum parameters.

1. Prior to conducting TP-201.3, the Permeator should be in the OFF position by turning the Hand/Off/Auto knob on the Control Panel Mounted Inside the Station Kiosk, as shown in Figure 8-2.
2. Conducting TP-201.3 with any dispenser piping test valve in the closed position is **not** permitted. Any dispenser with a dispenser piping test valve in the closed position while conducting TP-201.3 will bias the test towards compliance.
3. After conducting TP-201.3, the Permeator should be switched back into the AUTO position by turning the Hand/Off/Auto knob on the Control Panel Mounted Inside the Station Kiosk, as show in Figure 8-3.

Required Steps	Verification (please circle)
1. Permeator Hand/Off/Auto Control Knob in OFF position before conducting TP-201.3	Yes No
2. All dispenser piping test valves open before conducting TP-201.3	Yes No
3. Permeator in Hand/Off/Auto Control Know in AUTO position after conducting TP-201.3.	Yes No

Test Company: _____ Facility Name: _____

Print Name (Technician) Signature Date

Technician Certification Number ICC or Expiration Date
District Training Certification, as applicable)

FIGURE 8-2
Configuration of Permeator Control Panel Hand/Off/Auto
Control Knob in OFF position to Conduct TP-201.3



Items Required to Conduct TP-201.3

FIGURE 8-3
Configuration of Permeator Control Panel Hand/Off/Auto
Control Knob in AUTO position after Conducting TP-201.3

