

**WAYNE-DRESSER OVATION™ SERIES DISPENSER RETROFIT for
HEALY SYSTEMS, INC.
MODEL VP1000
VAPOR RECOVERY ASSIST SYSTEM
(KIT Z079)**

OUTLINE

This Manual is to be used for new, replaced, retrofitted, or reconditioned dispensers/pumps.

- 1. Purpose**
 - 2. Safety**
 - 3. Models Covered**
 - 4. Parts Lists**
 - 5. Tools Required**
 - 6. Dispenser Access**
 - 7. Survey Scope Of Work**
 - 8. Wayne-VAC Removal**
 - 9. Balance Removal**
 - 10. Installing The Healy VP1000 System**
 - 11. Connecting Vapor Lines**
 - 12. Installing The Sealed Nipple Assembly**
 - 13. Wiring Inside The Electronics Compartment**
 - 14. Connecting Healy Systems Dispensing Equipment**
 - 15. VP1000 Theory Of Operation**
 - 16. Testing The System**
 - 17. Trouble Shooting The VP1000**
 - 18. VP1000 Vane & Rotor Service & Replacement Guide**
- Start-up/ New Installation/ Warranty/ Annual Testing Form**

1. PURPOSE:

This procedure describes the tools, methods and skill levels required to install a Healy Systems, Inc. Model VP1000 Vapor Recovery pump in vapor ready Wayne Dresser Ovation™ series gasoline dispensers. Only Healy trained and certified contractors will be able to perform these retrofits or warranty will be void. The installer shall be a skilled petroleum technician and thoroughly familiar with the requirements of State, Federal and local codes for installation and repair of gasoline dispensing equipment. Also, they shall be aware of all the necessary safety precautions and site safety requirements to assure a safe and trouble free installation.

NOTE: All electrical and hydraulic plumbing fittings referred to in these instructions must be UL “listed” or “recognized” for the purpose.

Note: Installations of vapor piping into the inlet side of the vacuum pump should be sloped such that the natural flow direction is toward the vacuum pump. However, it is permissible to have a piping slope tilted away from the vacuum pump provided that all other applicable tests (Dispenser integrity and V/L) meet the specifications outlined in the appropriate section of the Executive Order and **CARB Approved Installation, Operation and Maintenance Manual**.

Note: For installations with In-Station Diagnostics (ISD), the vapor flow meter shall be installed on the down stream side of the vacuum pump. Every effort shall be made to install the vapor flow meter so that vapor piping between the vacuum pump and the vapor flow meter is sloped such that the natural flow direction is toward the vapor flow meter. However, it is permissible to have the piping slope away from the vapor flow meter provided that all other applicable tests (Dispenser integrity, V/L and ISD Operability) meet the specifications outlined in the appropriate section of the Executive Order and **CARB Approved Installation, Operation and Maintenance Manual**.

2. SAFETY:

Before installing the equipment, read, understand and follow:

- The National Electrical Code (NFPA 70)
- The Automotive and Marine Service Code (NFPA 30A)
- Any national, state and local codes that may apply

The failure to install the equipment in accordance with NFPA 30A and 70 may adversely affect the safe use and operation of the system.

Accurate, sound installations reduce service calls: Use experienced, licensed contractors that practice accurate, safe installation techniques. Careful installation provides a sound troubleshooting framework for field repairs and can eliminate potential problems.

1. Read all instructions before beginning.
2. Follow all safety precautions:
 - ❑ Barricade the area.
 - ❑ Do not allow vehicles or unauthorized people in the area.
 - ❑ Do not smoke or allow open flames in the area.
 - ❑ Do not use power tools in the work area.
 - ❑ Wear eye protection during installation.
3. Use circuit breakers for multiple disconnects to turn off power and prevent feedback from other dispensers.

3. MODELS COVERED:

Wayne-Dresser Ovation™ series dispensers, all options except suffix “O”, non vapor ready.
The addition of the Healy Systems VP1000 to the Ovation dispenser will increase the current draw of the dispenser by 2 amps. Use the label supplied to note this change.

4. PARTS LISTS: (See Photo A)

- 1 VP1000 Vacuum Pump
- 1 1365A Wire Harness / MC100 Series Interface Module Assembly

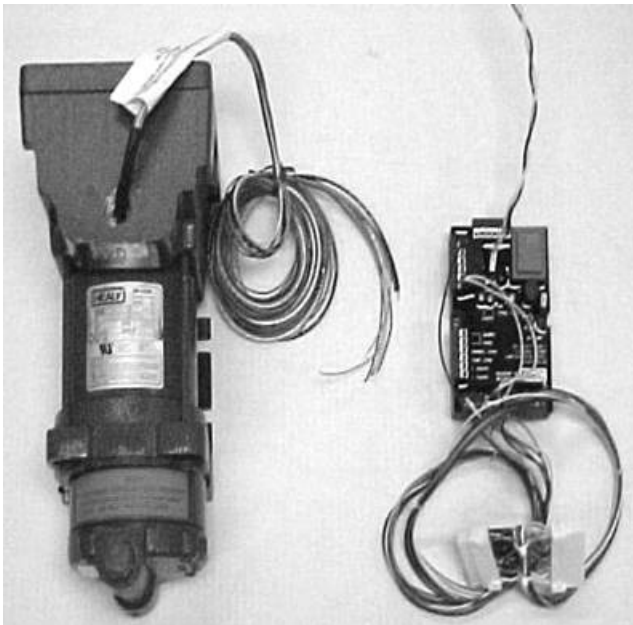

Photo A

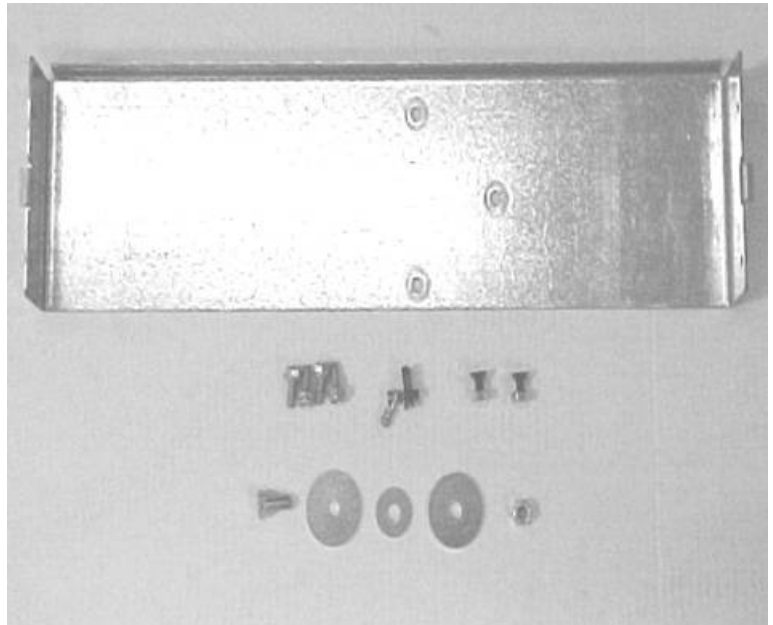

Photo B

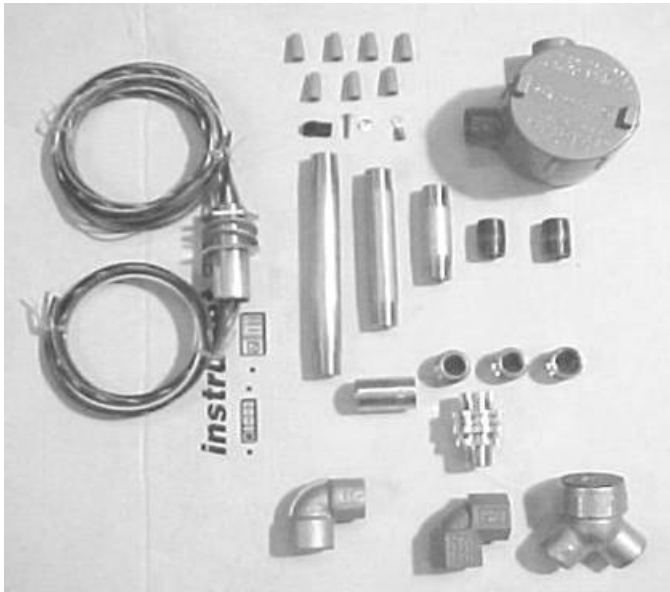

Photo C

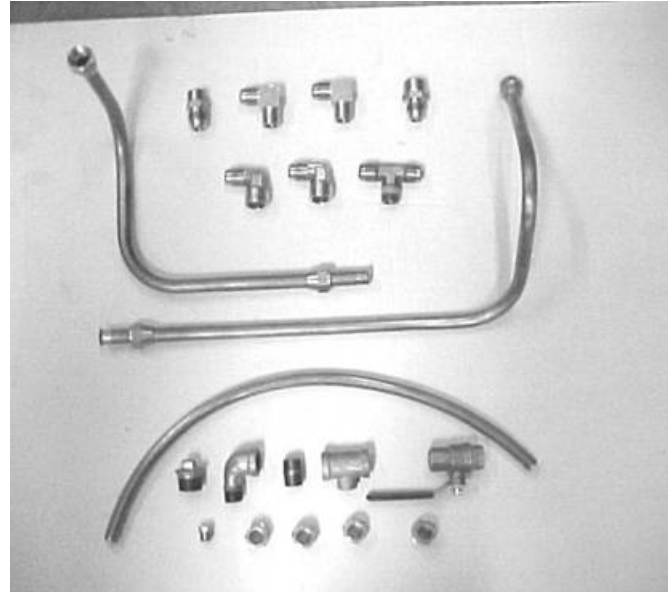

Photo D

HARDWARE KIT Z079H: (See Photo B)

- 2 ea Flat head 1/4-20 x 5/8 bolts, washers, and nuts
- 4 1/4 - 20 x 1/2" sheet metal screws
- 1 Washer-seal assembly (For use when removing Wayne-VAC electrical)
- 1 Pump mounting bracket

ELECTRICAL KIT Z079E: (See Photo C)

- 1 Current change label (p/n 1405)
- 7 Wire nuts
- 1 8-32 Tinnerman™ threaded fastener
- 1 8-32 x 5/8" pan head screw with washer
- 1 1/2" x 3" electrical nipple
- 1 1/2" capped electrical elbow
- 1 1/2" electrical elbow
- 1 1/2" electrical union
- 3 1/2" x 3/4" electrical reducing bushings
- 1 Explosion proof J box
- 1 #1346 potted conduit nipple
- 1 #8 Ring tong terminal
- 1 Notice label (p/n 1406)
- 1 UL listed label (p/n 1410)

- 1 3/4" electrical elbow
- 2 1/2" electrical close nipples
- 1 1/2" electrical coupling
- 1 1/2" x 5" electrical nipple
- 1 1/2" x 7" electrical nipple

VAPOR KIT Z079V: (See Photo D)

- 1 1/2" NPT X 5/8 flare straight fitting
- 2 1/2" NPT X 5/8 flare elbow fittings
- 1 3/4" NPT x 5/8 flare straight fitting
- 2 3/4" NPT x 5/8 flare elbow fittings
- 1 1/2" NPT x 5/8 x 5/8 flare tee
- 2 Preformed copper tube segments
- 2' 5/8" OD copper tube, type 'L'
- 1 3/4" pipe plug
- 1 1/2" NPT street elbow
- 1 1/2" close nipple
- 1 1/2" x 1/4" x 1/2" reducing tee
- 1 1/2" ball valve
- 1 1/4" pipe plug
- 4 5/8" flare nuts

MATERIALS SUPPLIED BY INSTALLER:

- Thread Sealing Compound – non-Setting, UL Classified for use on all tapered threads, non-electrical, plumbing fittings
- Oil and gasoline compatible PTFE tape

4. TOOLS REQUIRED:

- 1/4" or 3/8" ratchet set w/ sockets 1/4" through 9/16" + 3" extension
- 9" lineman's pliers
- Assorted open end wrenches 1/4" through 3/4"
- Wire cutters/strippers 18 AWG and 26 AWG
- 1-1/8" greenlee type sheet metal punch
- Mechanical hand drill (egg-beater type)
- Assorted drill bits 1/16" through 7/16"

- ❑ Assorted screwdrivers (flat blade-one must be 1/8" wide and Phillips)
- ❑ 5/8" copper tube bending tool
- ❑ 5/8" copper tube flaring tool
- ❑ Copper tubing cutter
- ❑ Electrical multi-Oeter
- ❑ Small hand brush (1-1/2" thick, for clearing chips)
- ❑ 12" adjustable wrench
- ❑ 16" pipe wrench
- ❑ Tape measure
- ❑ Allen wrenches

6. DISPENSER ACCESS: (See Photos E & F)

- ❑ Secure Dispenser Access keys from Station Management.
- ❑ Lockout and tag-out all electrical power to dispenser being modified.
- ❑ Use keys to unlock and remove lower dress panels on dispenser and open access doors.



Photo E



Photo F

7. SURVEY – Scope of Work: *Perform this step before beginning steps 8 thru 13, (See Photo G)*

Read and familiarize yourself with the theory of operations sheet and wiring instructions for the VP1000 Vapor Pump. The installation of the pump is on the sheet metal bracket, supplied in the hardware kit, and then installed on the right side panel in the hydraulics area when facing the “A” side of the dispenser, (this is the side with the IGEM board #173976). From this survey, you will have an indication of where the vapor plumbing fittings need to go and where the electrical tubing will need to run. Notice also on the “B” side, lower left of the electronics board support column, there is either a plugged hole or a WayneVac conduit that goes from the hydraulics to the electronic compartment. The wires to the motor will pass through this hole. The sealed nipple is installed here. See Section 12.

CAUTION: ALL POWER TO DISPENSER UNDER MODIFICATION SHOULD BE COMPLETELY DISCONNECTED AND CAPPED OFF AT THE JUNCTION BOX TO AVOID UNINTENTIONAL FEEDBACK FROM OTHER DISPENSERS!!

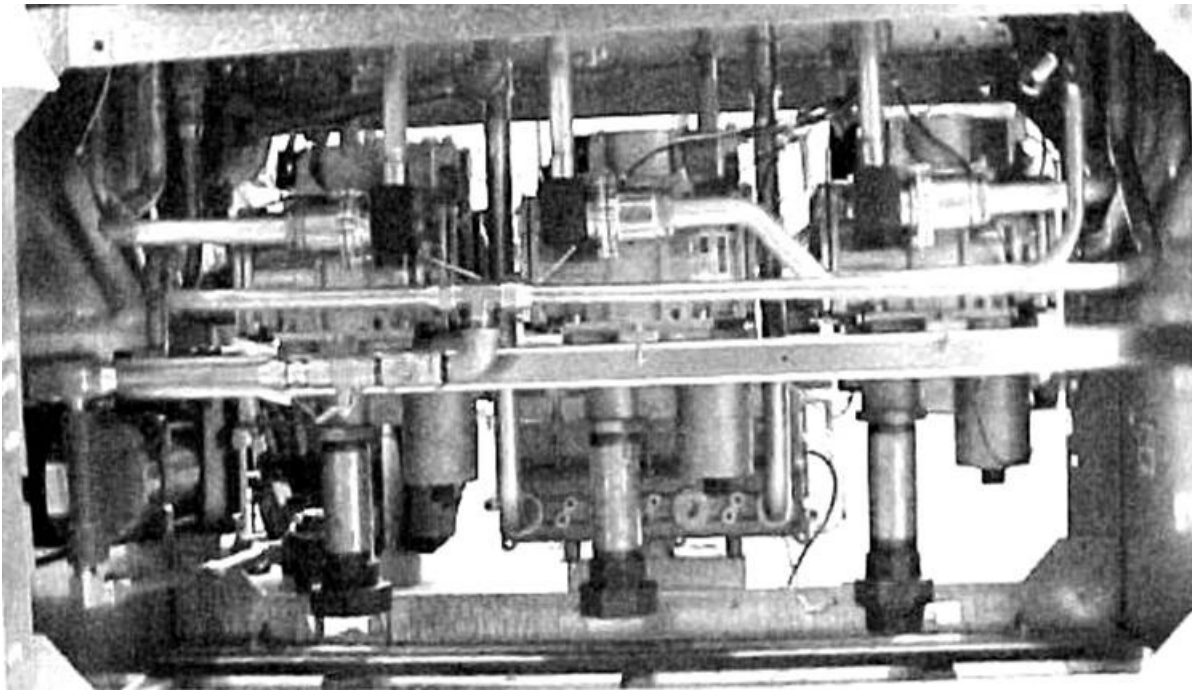

Photo G

NOTICE: Ovation dispensers may either be fitted with WayneVAC™ or Balance vapor recovery equipment. This equipment must be removed before the Healy VP1000 System is installed. See section 8 below for removal of a WayneVAC™ system. If Balance equipped, go to section 9 titled “Balance Removal”.

8. WAYNEVAC™ REMOVAL:

- ❑ Disconnect and lockout the power to the dispenser.
- ❑ Open the dispenser cabinet doors and observe vapor plumbing.
- ❑ Close the vapor recovery (Stage II vapor return line) impact valve. If there is no impact valve, be sure to have proper plugs or caps available to plug the Stage II line before disconnecting the WayneVAC™ equipment.
- ❑ On the 'B' side (side opposite IGEM board #173976, see photo H), of the dispenser locate the WayneVAC™ electronics control board #887227 photo I, and disconnect cables going to the WayneVac™ motors (4 connectors, 2 signal and 2 thermister). Also, remove 2 green ground wires going to the chassis.

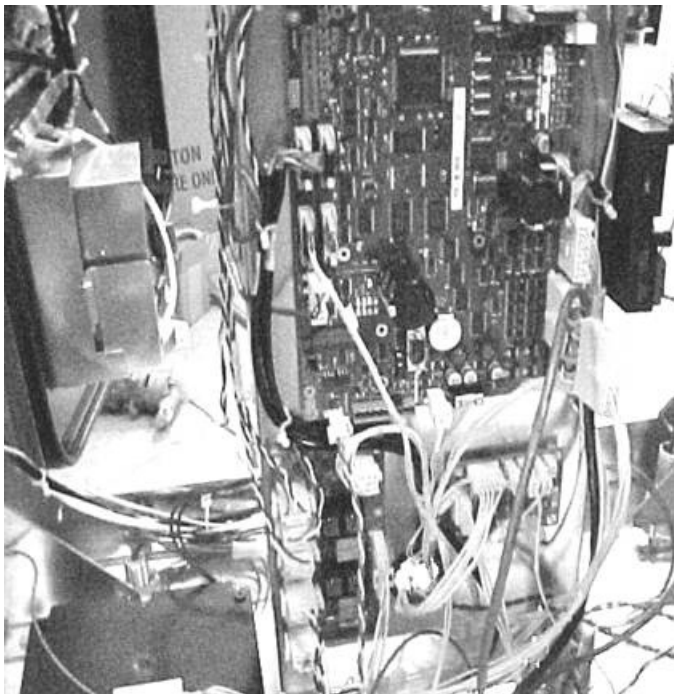

Photo H



Photo I

- ❑ On each motor, open the electrical union attached to the electronic housing, remove the covers, disconnect the cables, and ground wire inside.
- ❑ On each motor, follow the electronic wire conduit to where it penetrates the vapor barrier on the floor of the electronics compartment.
- ❑ On that conduit, back the lock nut off as far as it will go and then the coupling above the nut until the thread of the mating part, which is potted and comes from the electronic compartment through the barrier, is disengaged, see photo J.

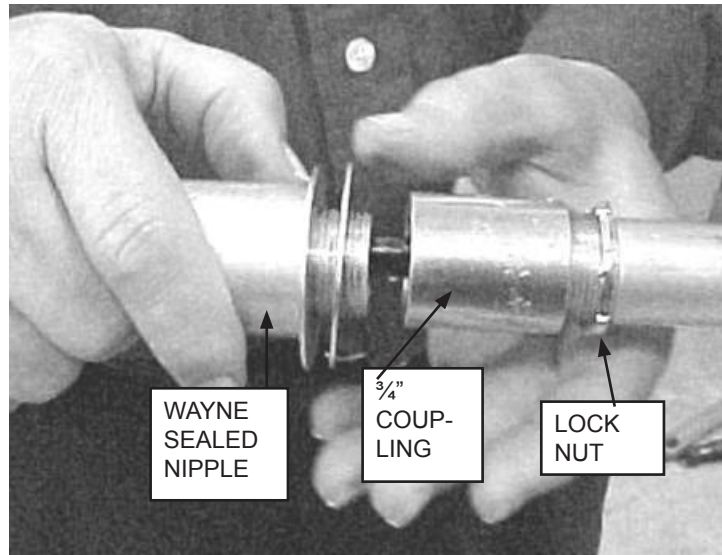

Photo J

- ❑ In the electronics compartment, remove the potted assembly (with wires) from the tubing and discard all.
- ❑ The hole on the “A” side in the vapor barrier where the potted assembly was removed needs to be plugged. Get the washer seal assembly from the parts kit and install in this hole. (The small washer fits between the two large washers and is the same thickness as the sheet metal). The hole on the “B” side will be used when installing the Healy System.
- ❑ Remove the vapor tubes from the flare fittings attached to the 3/4” couplings under the barrier and the inlet of each pump, see photos K & L.
- ❑ Remove the 3/4” NPT fitting from both 3/4” couplings. CAUTION: Use a pipe wrench on the 3/4” couplings when removing the 3/4” NPT fittings to prevent loosening of the upper vapor piping.
- ❑ Loosen and slide back the nuts on the vapor tubes connected to the outlet side of both WayneVAC™ pumps and the vapor cross that’s mounted to the base of the dispenser. NOTE: The vapor tubes will stay in the fittings until the VAC pumps are removed.
- ❑ Remove the sheet metal screws on each side that secure the VAC pump mounting bracket to the frame and remove pump/bracket assembly from dispenser and vapor tubing. On one end, it will be necessary to remove the product filter in order to get the pump/bracket assembly out. Be sure you have petroleum ‘diapers’ available to absorb any spilled fuel. NOTE: Reinstall product filter after VAC pump removal.
- ❑ Remove the 3/4” flare fittings from each side of the vapor cross.

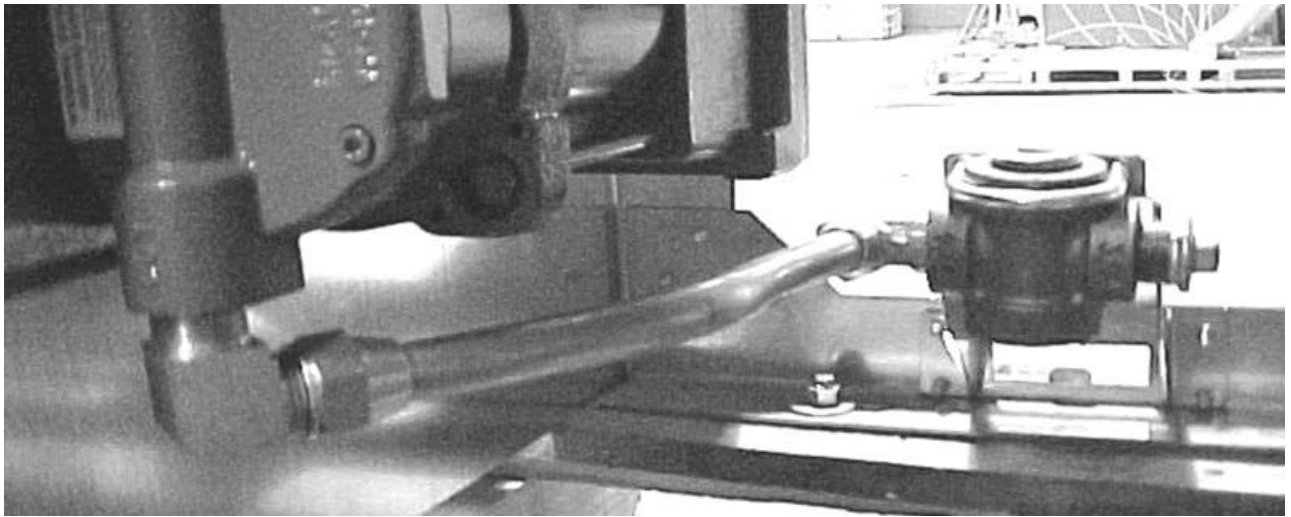

Photo K

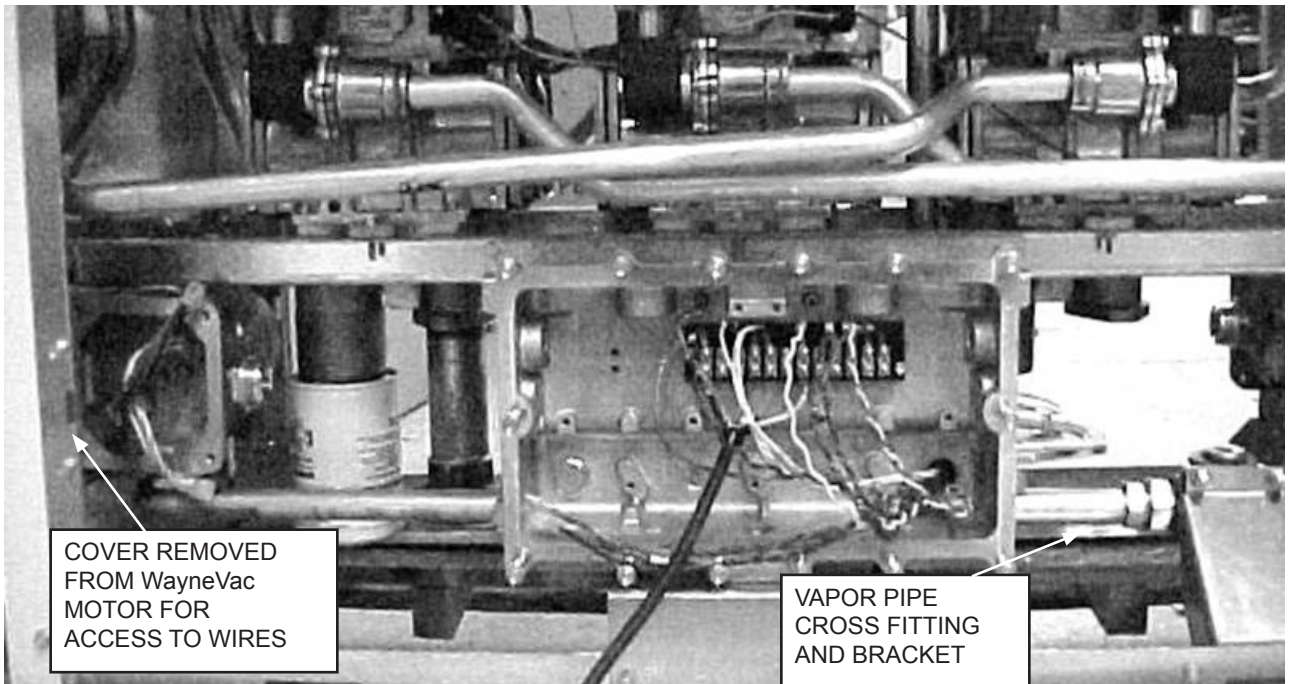

Photo L

9. BALANCE REMOVAL:

- ❑ Remove the vapor tubes from the flare fittings attached to the 3/4" couplings under the barrier and from the vapor cross.
- ❑ Remove the flare fitting from both 3/4" couplings of above. CAUTION: Use a pipe wrench on the 3/4" couplings when removing the flare fittings to prevent loosening of the upper vapor piping.
- ❑ Remove the flare fittings from each side of the vapor cross.

10. INSTALLING THE VP1000 SYSTEM:

NOTE: The mounting bracket on the VP1000 must be rotated 90° to secure the pump on this shelf. When installed in the dispenser, the vacuum pump INLET must be on top and the OUTLET on the bottom

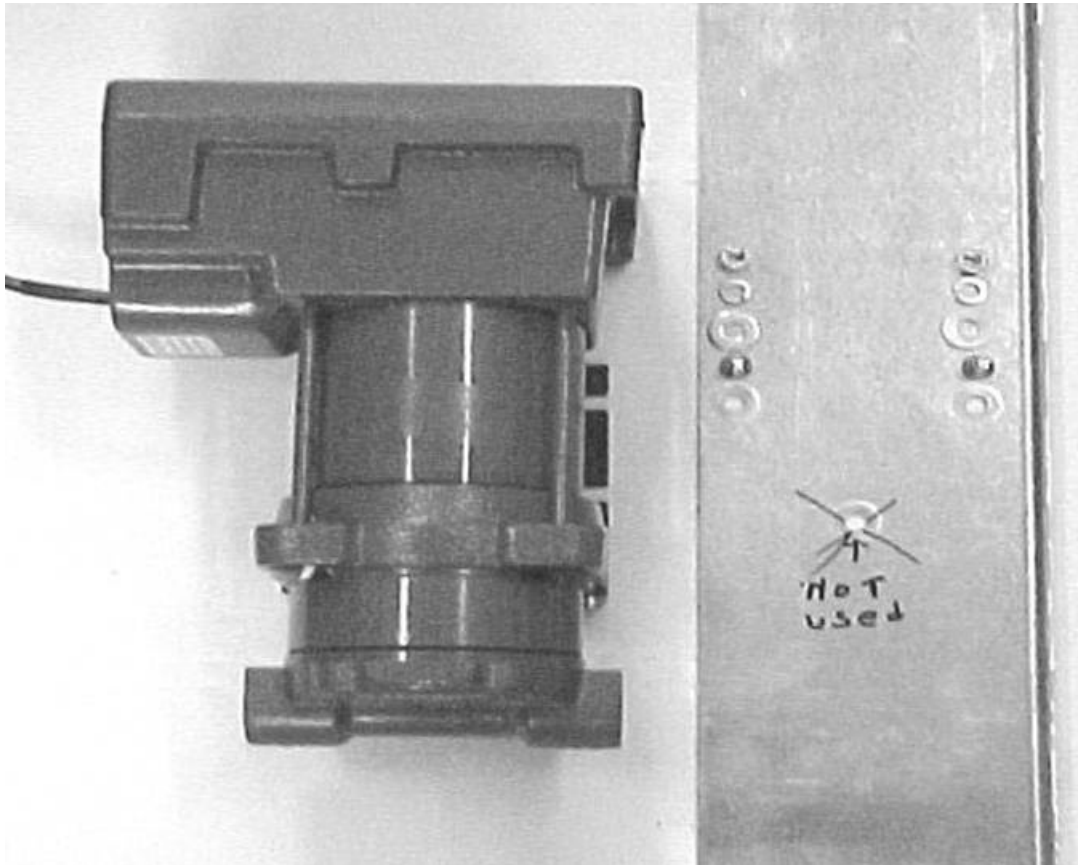

PHOTO M

- Place the VP1000 vapor pump on the sheet metal bracket with the pump end towards the left, upturned flange, see photo M. Secure with one 1/4-20 x 5/8" flat head cap screw, washer and nut in each of the motor mounting holes closest to the electrical end.

NOTE: DO NOT USE PIPE SEALING COMPOUND ON ANY ELECTRICAL CONDUIT FITTINGS.

Mount the electrical conduit on the VP1000: (See Photo N Below)

- Get the 1/2" x 3" conduit nipple and thread through the motor wires to secure the nipple into the motor.
- Install the 1/2" electrical elbow to the nipple from above – use care not to twist the wires during the installation. Completely tighten the elbow to face toward the rear of the VP1000, see photo N.
- Next, install, in the elbow, the 1/2" close nipple, followed by the female half of the electrical union.

- Lastly, use Oil and gasoline compatible PTFE tape to install a 1/2" NPT x 5/8" flare elbow in the 'IN' port of the pump. Face the elbow to the right when looking at the front of the pump, see photo N.

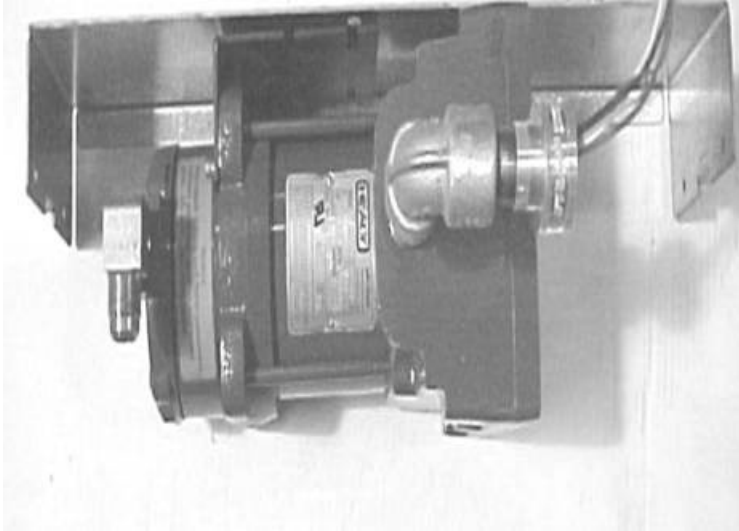

Photo N

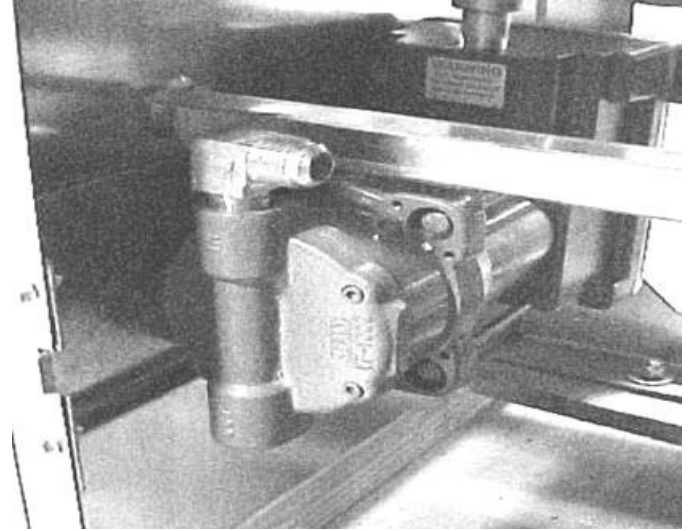

Photo O

Mount the VP1000 and the vapor plumbing:

- Mount the pump/bracket assembly in the dispenser from the "B" side, (this is the side opposite the IGEM board #173976) using four 1/4" x 1/2" sheet metal screws, see photo O, View From "B" Side.
- On the 'B' side of the dispenser, in the hydraulics area, locate the 3/4" vapor coupling on the right hand side under the vapor barrier. Install a 3/4" NPT x 5/8" flare elbow into the 3/4" coupling, completely tighten to face directly toward the cover panel opening.
- Still on the 'B' side, locate the left end 3/4" vapor coupling protruding from the vapor barrier. Install a 3/4" NPT x 5/8" flare straight fitting into the threaded hole.
- Get the preformed 5/8" tube labeled left and attach the short leg to the left fitting just installed. Do not completely tighten at this time.
- Get the preformed tubing labeled right and install in the right end elbow fitting. Do not completely tighten at this time.

11. CONNECTING VAPOR LINES: (ref. Photos P, Q & R)

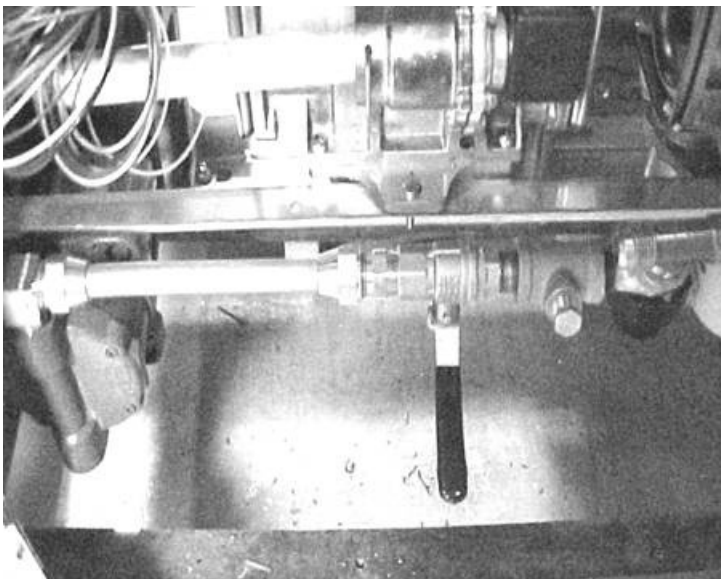

Photo P

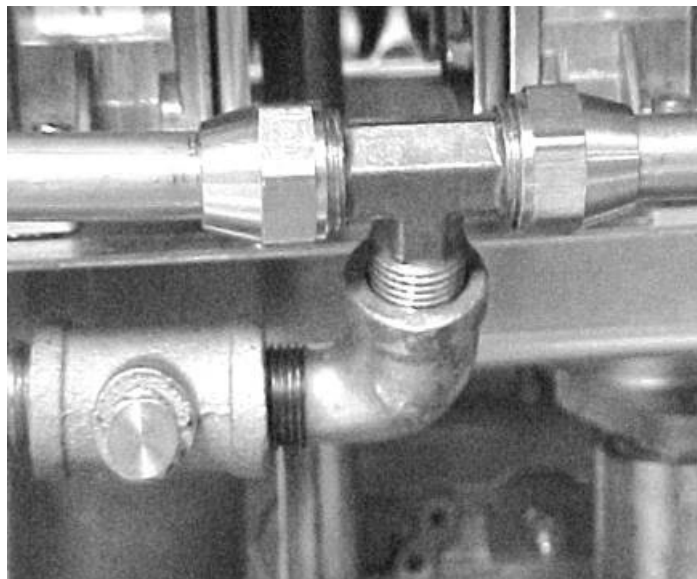

Photo Q

- ❑ Make the pipe thread connections below using pipe thread compound as required.
- ❑ Get the 1/2" NPT x 5/8" x 5/8" flare tee and insert between the two preformed 5/8" copper tubes to be sure the tubes can be securely tightened, but DO NOT COMPLETELY TIGHTEN.
- ❑ Remove the tee and thread into the 1/2" street elbow, tighten to position shown in photo Q. To the elbow, add the 1/2" reducing tee and orient tee so the 1/4" branch opening is 75° to the elbow (facing the installer) with the elbow on the right and facing up. Install the 1/4" plug into the 1/4" opening on the tee.
- ❑ Install the 1/2" close nipple into the tee and follow with the 1/2" ball valve. Orient the ball valve so the lever is on the bottom when the 1/4" plug is facing sideways, see photo P.
- ❑ Install the 1/2" x 5/8" straight flare fitting into the ball valve.
- ❑ Reinstall the 5/8" flare tee back between the two preformed pipes, with the flare fitting facing the VP1000 and final tighten the flare nuts. The ball valve lever should be on the bottom and the 1/4" pipe plug horizontal facing you. Be sure the slope of the two pipes is downward and slopes to the tee.
- ❑ Measure and cut a length of 5/8" OD copper tube necessary to run from the pump inlet flare fitting to the flare fitting on the ball valve. Cut the copper tubing and slide on the flare nuts before flaring the ends. Carefully position this vapor tube to align fittings for tightening. Secure tubing connections to the pump and ball valve. Use care not to kink the tubing and maintain the slope downwards.
- ❑ On the "A" side of the dispenser, install the 3/4" pipe plug to the left end of the vapor cross and the 3/4" NPT x 5/8" flare elbow in the right end. Completely tighten the flare elbow so it is horizontal to slightly upward facing the out port of the VP1000.
- ❑ On the 'B' side, install the 1/2" NPT x 5/8" flare elbow into the out port of the VP1000. Completely tighten until horizontal to downward facing the flare elbow on the vapor tee. (Use tape, not pipe dope)

- ❑ Measure and cut appropriate length of 5/8" copper tubing to reach from the flare fitting on the vapor cross to the fitting in the VP1000 out port. Use 5/8" tubing bender to fit pipe appropriately to fittings if necessary see photo K.
- ❑ Slide on the flare nuts before flaring the ends.
- ❑ Carefully position this vapor tube to align fittings for tightening. Secure tubing connections to the pump and vapor cross. Use care not to kink the tubing and maintain the slope downwards.

12. INSTALLING THE SEALED NIPPLE ASSEMBLY: (See Photos R & S)

NOTICE: THE INTERFACE MODULE THAT IS SUPPLIED HAS A HARNESS ATTACHED AND A WIRING PLUG FOR THE AC CONNECTIONS. ALSO SUPPLIED IS THE SEALED NIPPLE ASSEMBLY (1346) THAT MUST BE INSTALLED BETWEEN THE ELECTRONICS AND HYDRAULIC AREAS OF THE DISPENSER CABINET.

- ❑ Looking in the "B" side of the electronics cabinet, notice on the lower left of the electronics board support column, there is either a plugged hole (remove plug at this time), or an open hole where the WayneVac™ conduit was removed from the hydraulics to the electronic compartment. Get the 1346 Sealed Nipple assembly and remove the first nut and washer. Turn the remaining nut down on the nipple as far as it will go.
- ❑ Carefully slide the threaded nipple end wires down from the electronics cabinet to the hydraulics area see photo S.
- ❑ Slide the washer and nut removed above, back over the wires and thread on to the nipple, approximately 4 turns, do not tighten until electrical is complete see photo S.
- ❑ Install a 3/4" electrical elbow onto the sealed nipple. Tighten to face the female half of the electrical union that's attached to the VP1000.
- ❑ Install a 3/4" x 1/2" electrical reducing bushing to the 3/4" elbow followed by a 1/2" x 7" electrical nipple, then a 1/2" electrical coupling followed by a 1/2" x 5" electrical nipple.
- ❑ Get the "J" box and install a 3/4" x 1/2" reducing bushing in each 3/4" threaded hub.
- ❑ Position the "J" box as shown in photo R, pull wires through and install onto the 1/2" x 5" electrical nipple being careful not to twist the wires.
- ❑ Install a 1/2" electrical close nipple to the bottom port of the "J" box.
- ❑ Get the 1/2" pull elbow and remove the cover. Install onto the 1/2" close nipple and tighten to the position shown in photo R.
- ❑ Attach the male half of the electrical union to the pull elbow. Pull wires from the female half of the union through the male half, through the pull elbow and into the "J" box.
- ❑ Tighten the union half's together being careful not to pinch wires and install cap on elbow.
- ❑ Tighten the nuts on the sealed nipple to secure to barrier panel.

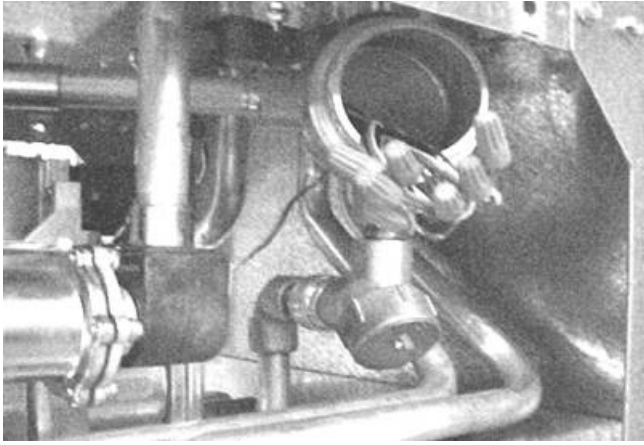

Photo R

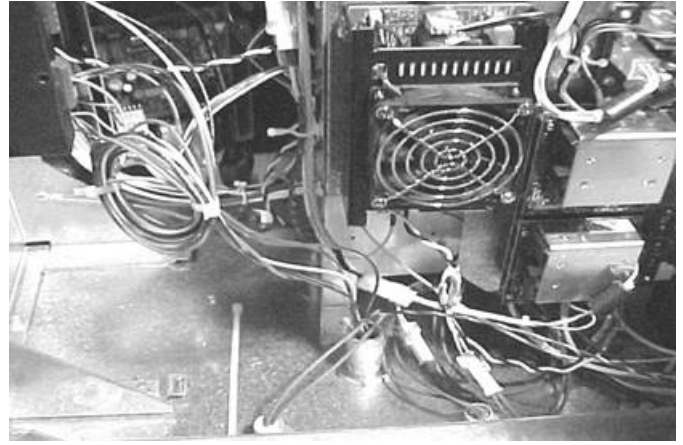

Photo S

- ❑ Leaving about 6" of wire on both the wires coming from the motor and from the sealed nipple, cut off excess wire and strip approximately 1/2" of insulation from all wires.
- ❑ Use wire nuts to join the wires, color for color, together. There may be some extra wires in some sealed nipples, cap these off and dress aside.
- ❑ Keep wires clear of pinch points and from interference, make sure no wires overhang the box openings and replace the cover on the junction box.

13. WIRING INSIDE THE ELECTRONICS COMPARTMENT

- ❑ Cut the wires coming from the sealed nipple assembly in the electronics cabinet at least twenty inches long and strip all wires 1/2".
- ❑ Connect the wires from the sealed nipple to the interface module as follows:
 - Black wire to 'motor ' on module
 - White wire to 'neutral' on module
 - Red wire (either) to 'output 1' on module
 - Red wire (other) to 'output 2' on module
 - Orange wire to 'fault common' on module
 - Purple wire to 'fault input' on module
 - Green wire needs a #8 ring tong lug installed and connected to any chassis ground (frame)
 - Some sealed nipples may have some extra wires, cap these and bundle them neatly out of the way.
- ❑ The black and white twisted pair of wires with a connector should be connected to an available AC outlet on the dispenser Relay Board #887225 see photo T.
- ❑ The male/female multiconductor cable that is wired to the interface module is routed up to the computer board, J3. Disconnect the valves cable already in J3 and install in the female side of the double connector on the harness. The entire assembly is then installed back into J3 on the Computer board #173976 see photo T.
- ❑ Carefully position the wired module on the edge of the center upright sheet metal panel "B" side, select a blank hole, and slide over the 8-32 Tinnerman nut supplied in the electronics kit. Mount the module to the Tinnerman clip using the 8-32 x 5/8" screw and washer supplied.

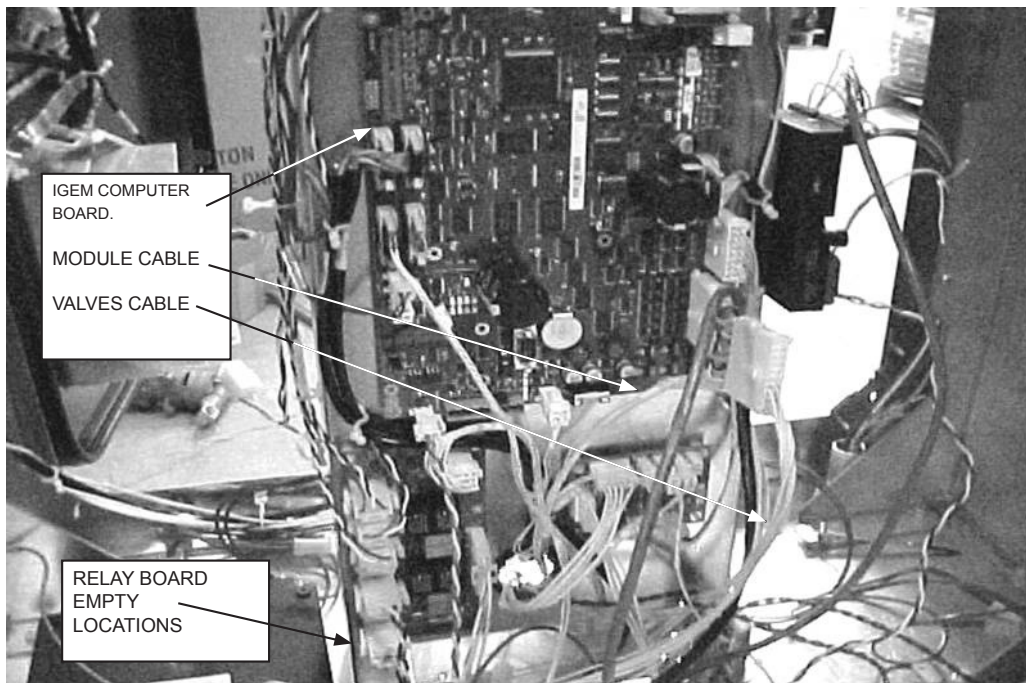

Photo T

- Install the following labels supplied:
 - NOTICE label for current increase (1405), install on the frame rail near the existing power consumption label.
 - Large NOTICE label (1406) relating to the vapor recovery upgrade and how to reset the electronic module should be installed near the module, where it will be readily visible to a service technician on the junction box cover.
 - UL, retrofit kit identification number (1410), install on the electronic module.

14. CONNECTING HEALY SYSTEMS DISPENSING EQUIPMENT

- Completing the connection of Healy Systems dispensing equipment requires the installation of Healy Systems Phase II dispenser adaptors, hoses and nozzles (Hanging Hardware).
- If applicable, remove existing non-Healy hanging hardware (from the dispenser product outlet adaptor to and including the nozzles).
- Vapor ready dispensers may require a Healy Systems adaptor to make the hose threads compatible with other Healy Systems equipment. Install necessary adaptor following instructions packed with the adaptor. Various adaptors and pigtails are available, depending on how the dispenser is configured: M34 metric (Healy designation F3 or S3) or balance ready (Healy designation S4).
- Healy Vapor Recovery Hoses are available in various lengths to satisfy local ordinances and still provide “far side” fueling capability. Install these following instructions contained on the shipping box.
- Breakaways are required: Install either Model 8701VV breakaway or Model 807 swivel breakaway; install using the instructions supplied with the unit.
- The Healy Systems nozzle Model 900 (EVR) is the only nozzle necessary to complete the upgrade. Check to be sure the nozzle hanger is mounted in the highest position. Be sure to check for proper fit in the nozzle holster and that the nozzle can be locked in the off position. Also, be sure that when the nozzle is locked, that the dispenser can not be activated from the locked position.

15. VP1000 Theory of Operation

The Healy Systems VP1000 is a self-contained rotary vane pump, designed for gasoline vapor recovery utilizing various parts of the Healy System Vapor Recovery product line. It is intended for use by either OEM dispenser/pump manufacturers or as an after market add-on to make existing equipment compatible with Healy System technology. In order to convert to ‘others’ equipment, an electronic interface is required to adapt the targeted pump/dispenser to the new vapor recovery equipment. The interface senses when authorization to dispense has been given and sends signals to the motor to operate at a low speed for one hose, or a higher speed for two hoses. It also functions to shut off the pump/dispenser if it senses that the vapor pump is not operating properly. The vacuum is regulated at a level sufficient to clear liquid gasoline from the vapor path in MPD applications. The actual amount of vapors withdrawn is controlled by the Healy nozzle, itself, in response to the liquid gasoline flow rate.

MOTOR SPECIFICATIONS

Horsepower	1/8 HP
Voltage	120 VAC

INTERFACE SPECIFICATIONS

Input voltage	120 VAC
Relay current capacity	5AAC
Input signals	AC and DC voltages up to 130 VAC max
Motor Input signal	5 VDC @ 20 Hz 50% Duty Cycle

16. TESTING THE SYSTEM:

- Carefully review all work completed, being sure all mechanical joints are thoroughly tightened and electrical connections sealed.
- Open the product crash valves and restore power to the dispenser.
- With the power on, but no nozzles authorized, the VP1000 should not be running (unless the ambient temperature is below 40°F), but the power LED (yellow) should be energized on the interface module.
- Authorize one handle and the vacuum system should activate when the gasoline flow control valve is engaged. Repeat for all other nozzles, individually testing each nozzle on each side of dispenser. With each authorization, one of the green LED's on the interface module should illuminate and the VP1000 activate.
- Note: For unihose dispensers, conduct individual tests for each product grade on each side of the dispenser to ensure that the same LED activates for all grades on the same side. If the other LED activates, wiring needs to be corrected.
- Authorize one nozzle and listen to the speed of the VP1000. With only one nozzle activated, the speed will be slower than if a nozzle on each side is activated. Activate a nozzle on the other side of the dispenser and listen for the speed to change.
- To test the tightness of the vapor plumbing installed on the suction side of the system requires a 0-100" water column gauge. Connect the gauge into the 1/4" test port of the reducing tee installed earlier in section 11 Photo P. Continue by following and completing the START-UP / NEW INSTALLATION / WARRANTY / ANNUAL TESTING FORM.

17. TROUBLESHOOTING VP1000

- ❑ Use extreme care and caution when performing the tests listed below. If 120 VAC is accidentally applied to the fault or DC terminals, the module will be destroyed.
- ❑ With power applied to the dispenser, but no products authorized, there should be 120 VAC between neutral and power in on the module terminal strip.
- ❑ As above, with any product authorized, there should be single speed power applied to the VP1000. Verify this by checking for 2-3 VDC from OUTPUT 1 (RED WIRE) to FAULT COMMON (ORANGE WIRE), (or from OUTPUT 2 TO FAULT COMMON) also; one GREEN LED should be illuminated. With a second product authorized on the opposite side of the dispenser i.e. one product on each side, the motor should operate at higher speed and there should be 2-3 VDC on both output 1 and 2 (to fault common) and both GREEN LED's should be illuminated.
- ❑ With the pump running, a fault can be simulated by shorting, with a jumper wire, the "FAULT INPUT" (purple wire) to FAULT COMMON (orange). This should cause the motor to shut off, the solenoid valves to lose power and the dispenser to shut down. Also, as long as the short is maintained, the red LED will be illuminated. Removing the short will not automatically reset the module. To reset the module, remove the short, remove power to the dispenser for twenty seconds and restore power. The module should now be reset and the red led extinguished. This can also be accomplished by using the power reset (PWR RESET) on the module.
- ❑ If diagnosing a problem where the LED is already illuminated, a steady light indicates a low current condition, therefore expect a vane or rotor problem. If the LED is blinking, that indicates a high current condition and would expect to find a jammed rotor or vapor line flooded with product. See Start-up / New Installation / Warranty / Annual Testing Form.
- ❑ The electronics of the motor will make three attempts to have a successful start of the motor. If it detects a problem, on the fourth unsuccessful start, it will short the fault line to signal minus (DC-) and shut down the electronics.

MC100 Interface Module



18. VP1000 VANE & ROTOR SERVICE & REPLACEMENT GUIDE

Caution  **Disconnect power before beginning service.**

1. The work area **must** be clean and have sufficient lighting.
2. Disconnect the vapor piping connected to the **IN** and **OUT** ports of the VP1000 cover assembly.
3. Remove the four Allen head screws and lock washers that secure the pump cover assembly to the pump housing and remove the cover carefully.

Caution  **Use a spill cloth when removing the cover, as there may be some gasoline inside the pump cavity.**

4. Carefully turn the rotor assembly by hand until the shaft key notch is at the 12 o'clock position. (See Figures)
5. Remove the rotor, vanes and shaft key from the pump housing.

Note: Place your hand or a container under the rotor while removing. Do not use any sharp objects that would scratch the surfaces of the pump cavity, pump shaft, rotor, or vanes.

6. Rotate the shaft by hand. If the shaft does not rotate freely, the entire vacuum pump needs replacement (p/n VP1000-5 or RVP1000-5).
7. If the rotor and vanes are cracked, chipped, excessively worn or excessively dirty, the rotor and vanes should be replaced because cleaning will not remedy these conditions (p/n VP1000VRC-G, VP1000VRC-P or VP1000VRC).
8. If there is no visible damage, use a lint-free cloth with isopropyl alcohol to clean the rotor and vanes.
9. Using a lint-free cloth with isopropyl alcohol, thoroughly clean: the inside of the pump ring and rear of the pump cavity, the rotor shaft, and the inside of the pump cover.
10. Reposition the shaft (if necessary) so that the shaft key notch is in the 12 o'clock position. Install the cleaned original or new shaft key onto the shaft.
11. Carefully install the cleaned original or new rotor onto the shaft followed by the cleaned original or new vanes into the rotor.

Note: The rotor assembly should slide on to the shaft easily, without excessive force. (Rotors and vanes are reversible)

12. Lightly lubricate and install the new O-Ring for the pump housing.

Note: Do not allow any lubricant to get inside the pump housing.

13. Install the pump cover using the four Allen head screws and lock washers removed in step 3 and cross tighten.

Note: Use caution when sliding the pump cover over the O-Ring seal to prevent cutting or tearing.

14. Re-connect the vapor piping to the **IN** and **OUT** ports of the pump cover assembly that was removed in Step 2.
15. Re-apply power. Test for normal operation. (See VP1000 Vacuum Performance Test Procedure)

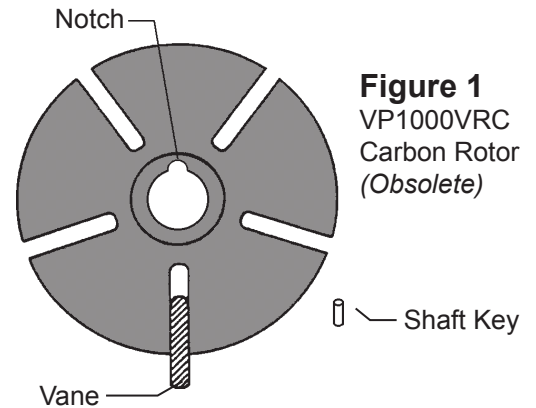

Figure 1
VP1000VRC
Carbon Rotor
(Obsolete)

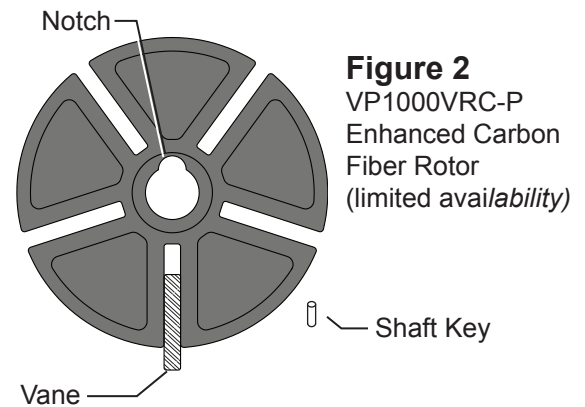

Figure 2
VP1000VRC-P
Enhanced Carbon
Fiber Rotor
(limited availability)

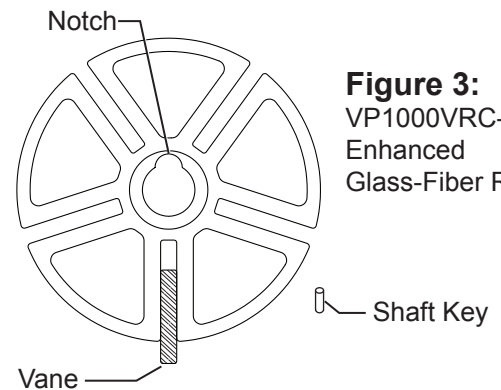

Figure 3:
VP1000VRC-G
Enhanced
Glass-Fiber Rotor

START-UP/NEW INSTALLATION/ WARRANTY/ ANNUAL TESTING FORM (Rev. 10/07)
HEALY VP1000 VACUUM PUMP

Date _____

BOTH SIDES OF THIS TEST FORM MUST BE COMPLETED FOR NEW INSTALLATIONS

- **Start-up / New installations** – complete **SIDE A** and sections 3, 4, 5 and 6 of **SIDE B**. Submit forms to Healy Systems.
- **Warranty Service or Annual Testing** – complete contact information, dispenser make, vacuum pump serial # and the tests in sections 1 and 2 on **SIDE A** and conduct the appropriate tests specified on **SIDE B**. Submit Forms to Healy Systems.

SERVICE COMPANY NAME	TELEPHONE	
SERVICE TECHNICIAN	HEALY TECH CERT #	
STATION ADDRESS	CITY	STATE
DISPENSER MAKE	VACUUM PUMP SERIAL #	

SIDE A

DISPENSER EQUIPMENT CHECKLIST - Parts A-1 and A-2	YES	NO*
A-1 Is all the installed dispenser hanging hardware listed in Exhibit 1 of Executive Order VR-201 or VR-202?	<input type="checkbox"/>	<input type="checkbox"/>
A-2 Proper installation of the VP1000 requires the test port and ball valve on the inlet side of the vacuum pump. Are the test port and ball valve installed correctly?	<input type="checkbox"/>	<input type="checkbox"/>
*If the answer to either A-1 or A-2 is NO, the Healy Warranty is Void.		

A-3

- THE FOLLOWING TEST WILL PERFORM A POSITIVE PRESSURE LEAK CHECK OF THE VACUUM PUMP, DISPENSER VAPOR PIPING, HANGING HARDWARE AND ALL NOZZLES ON BOTH SIDES OF THE DISPENSER.
- THE VP1000 OUTLET IS NOT CONNECTED TO UNDERGROUND PIPING DURING THIS TEST.

CAUTION: REGULATE GASEOUS NITROGEN TO 2.5 PSI (~70" WC) MAXIMUM BEFORE TESTING

1. Install a 0-100 inch water column (" wc) mechanical gauge at the VP1000 test port.
2. Use the water column gage positive (high) pressure port.
3. Gaseous nitrogen gas can now be connected to the outlet (exhaust) port of the VP1000.
4. Test pressure **cannot** exceed 70" wc.
5. **Slowly** introduce the gaseous nitrogen to a pressure between 60 – 70" wc.
6. After reaching the pressure range, close the valve supplying the gaseous nitrogen.
7. Record the initial pressure reading on the gauge - observe and record the final pressure reading after 60 seconds.
8. Leaks must be repaired when the pressure falls more than 4" wc in 60 seconds.
9. Retest until all leaks have been repaired.
10. Record test results in Section A-4.

A-4 PRESSURE TEST 2.5 PSI (~70"wc) Maximum	Initial Pressure test reading ("wc)	Pressure test reading after 60 seconds ("wc)
--	-------------------------------------	--

START-UP/NEW INSTALLATION/ WARRANTY/ ANNUAL TESTING FORM (Rev. 10/07)
HEALY VP1000 VACUUM PUMP

Date _____

BOTH SIDES OF THIS TEST FORM MUST BE COMPLETED FOR NEW INSTALLATIONS

- **Start-up / New installations** – complete **SIDE A** and sections 3, 4, 5 and 6 of **SIDE B**. Submit forms to Healy Systems.
- **Warranty Service or Annual Testing** – complete contact information, dispenser make, vacuum pump serial # and the tests in sections 1 and 2 on **SIDE A** and conduct the appropriate tests specified on **SIDE B**. Submit Forms to Healy Systems.

SIDE B			
<i>Warranty Service</i> Complete Troubleshooting Sections B-1 and B-2		<i>Start-up/ New Installations/ Annual Testing</i> Complete Sections B-3 through B-6	
B-1	Control Module Fault Light (Circle one) Flashing (LED) Steady (LED)	1. All fault conditions require removal and cleaning or replacement of the rotor and vanes located inside the vacuum pumps round front cover assembly. Use the VP1000 ROTOR & VANE SERVICE AND REPLACEMENT GUIDE in the applicable dispenser retrofit manual of the ARB Approved Installation, Operation and Maintenance Manual for Executive Orders VR-201-O and VR-202-O. 2. Clean all surfaces including vanes, rotor, rotor housing and cover assembly. 3. Manually spin and inspect the motor shaft for bearing wear before re-installing the rotor kit. 4. Replace motor when bearings or shaft are damaged or worn. 5. Check O-ring seal before replacing rotor cover assembly.	
B-2	Re-Assemble / Reset Vacuum Pump and Module. (Power must be removed from both the vacuum pump and the module for 20 seconds to reset the system) using the power reset switch on the MC100 module.		
B-3 Dispenser Vapor Line Integrity Test	1. Install 0-100 inch water column (“ wc) vacuum mechanical gauge at the VP1000 test port. 2. Authorize the dispenser for fueling. The VP1000 will begin to run. 3. Close the ball valve at the pump inlet. 4. Record the initial vacuum reading on the gauge – observe and record the final vacuum reading after 60 seconds. 5. Open the ball valve at the pump inlet. 6. Leaks must be repaired when the vacuum reading falls more than 4” wc in 60 seconds. 7. Retest until all leaks have been repaired. 8. Record data in Section B-4. Note: If the initial vacuum reading is less than 60” wc, it could indicate a problem with the VP1000. Remove the dispenser from service. Use the troubleshooting section of the manual to investigate problem or contact the FFS Technical Help Desk at 800-984-6266 for assistance.		
B-4	VACUUM TEST Using VP1000 as vacuum source	Initial Vacuum test reading (“ wc)	Vacuum test reading after 60 sec. (“ wc)
B-5 Dispenser Vacuum Test	With one side of the dispenser authorized (VP1000 running) and the ball valve at the pump inlet open, dispense in handheld position a minimum of 0.5 gallons of fuel into a vehicle or test tank. Record the vacuum level while dispensing. Repeat test for the other side of the dispenser. 1. Side “A” Dispensing Vacuum _____” wc 2. Side “B” Dispensing Vacuum _____” wc Note: If the dispensing vacuum is less than 60” wc, remove the dispenser from service. See the troubleshooting section of the manual or contact FFS Technical Help Desk at 800-984-6266 for assistance.		
B-6 Audible Increase Test	Test the VP1000 Vacuum Pump for normal operation. Use the 6 step procedure titled, “Testing the VP1000 Vacuum Pump for normal operation using the following test procedure.” in Section 1.1 (Weekly Inspection and Testing) of the Healy Systems Scheduled Maintenance document in the ARB Approved Installation, Operation and Maintenance Manual for the Healy Phase II EVR System not Including ISD. This is to verify that the pump recognizes when both sides of the dispenser are activated for fueling. Does the VP1000 Vacuum Pump change speeds (audible increase) when both sides are activated for fueling? Yes No If the answer is no, use the troubleshooting section of the manual to investigate problem or contact the FFS Technical Help Desk at 800-984-6266 for assistance.		
Repairs - Comments		To Obtain Returned Materials Authorization number (RMA#) Call 800-984-6266 Forms can be faxed to Franklin Fueling Systems Customer Service at 800-225-9787	

Franklin Fueling Systems
3760 Marsh Road
Madison, Wisconsin 53718 USA
ARB Approved Installation, Operation and Maintenance Manual

Website: <http://www.franklinfueling.com>
Email: sales@franklinfueling.com
Telephone: 800-225-9787
Fax: 608-838-6433

