

**GILBARCO ENCORE™ 300 & 500 SERIES  
DISPENSER RETROFIT with VDC control valves  
for HEALY SYSTEMS, INC. MODEL VP1000  
VAPOR RECOVERY ASSIST SYSTEM  
(KIT Z082 & Z083)**

**OUTLINE**

**Notice: USE THIS PROCEDURE IF CONVERTING A BALANCE OR GILBARCO VaporVac™  
VAPOR RECOVERY SYSTEM TO A HEALY VAPOR RECOVERY ASSIST SYSTEM**

This Manual is to be used for new, replaced, retrofitted, or reconditioned dispensers/pumps.

**See Section 15 For Dispensers With VaporVac™ Systems**

- 1. Purpose**
- 2. Safety**
- 3. Models Covered**
- 4. Parts Lists**
- 5. Tools Required**
- 6. Dispenser Access**
- 7. Survey Scope of Work**
- 8. Installing The Healy VP1000 System (For installations w/ ISD, see Section 18 regarding VP1000 position)**
- 9. Installing The Sealed Nipple Assembly**
- 10. Wiring Inside The Electronics Compartment**
- 11. Connecting Healy Systems Dispensing Equipment**
- 12. VP1000 Theory Of Operation**
- 13. Testing The System**
- 14. Trouble Shooting The VP1000**
- 15. VaporVac™ Removal**
- 16. Nozzle Hook Adjustment**
- 17. VP1000 Vane & Rotor Service & Replacement Guide**
- 18. Location Change of Healy VP1000 on Encore Series ISD Enabled Dispensers  
Start-up/ New Installation/ Warranty/ Annual Testing Form**

## 1. PURPOSE:

This procedure describes the tools, methods and skill levels required to install a Healy Systems, Inc. Model VP1000 Vapor Recovery pump in vapor ready Gilbarco Encore™ 300 and 500 series gasoline dispensers. Only Healy trained and certified contractors will be able to perform these retrofits or warranty will be void. The installer shall be a skilled petroleum technician and thoroughly familiar with the requirements of State, Federal and local codes for installation and repair of gasoline dispensing equipment. Also, they shall be aware of all the necessary safety precautions and site safety requirements to assure a safe and trouble free installation. NOTE: All electrical and hydraulic plumbing fittings referred to in these instructions must be UL “listed” or “recognized” for the purpose.

**Note:** Installations of vapor piping into the inlet side of the vacuum pump should be sloped such that the natural flow direction is toward the vacuum pump. However, it is permissible to have a piping slope tilted away from the vacuum pump provided that all other applicable tests (Dispenser integrity and V/L) meet the specifications outlined in the appropriate section of the Executive Order and **CARB Approved Installation, Operation and Maintenance Manual**.

**Note:** For installations with In-Station Diagnostics (ISD), the vapor flow meter shall be installed on the down stream side of the vacuum pump. Every effort shall be made to install the vapor flow meter so that vapor piping between the vacuum pump and the vapor flow meter is sloped such that the natural flow direction is toward the vapor flow meter. However, it is permissible to have the piping slope away from the vapor flow meter provided that all other applicable tests (Dispenser integrity, V/L and ISD Operability) meet the specifications outlined in the appropriate section of the Executive Order and **CARB Approved Installation, Operation and Maintenance Manual**.

## 2. SAFETY:

Before installing the equipment, read, understand and follow:

- The National Electrical Code (NFPA 70)
- The Automotive and Marine Service Code (NFPA 30A)
- Any national, state and local codes that may apply.

The failure to install the equipment in accordance with NFPA 30A and 70 may adversely affect the safe use and operation of the system.

Accurate, sound installations reduce service calls: Use experienced, licensed contractors that practice accurate, safe installation techniques. Careful installation provides a sound troubleshooting framework for field repairs and can eliminate potential problems.

1. Read all instructions before beginning.
2. Follow all safety precautions:
  - ❑ Barricade the area.
  - ❑ Do not allow vehicles or unauthorized people in the area.
  - ❑ Do not smoke or allow open flames in the area.
  - ❑ Do not use power tools in the work area.
  - ❑ Wear eye protection during installation.

3. Use circuit breakers for multiple disconnects to turn off power and prevent feedback from other dispensers.

### 3. MODELS COVERED:

Gilbarco 300 and 500 Encore™ series dispensers with VDC control valves, all options except non-vapor ready. The addition of the Healy Systems VP1000 to the Encore dispenser will increase the current draw of the dispenser by 2 amps. Use the label supplied to note this change.

### 4. PARTS LISTS: (See Photo A)

- 1 VP1000 Vacuum Pump
- 1 1373A Wire Harness / MC100 Series Interface Module Assembly
- 1 Interrupt jumper

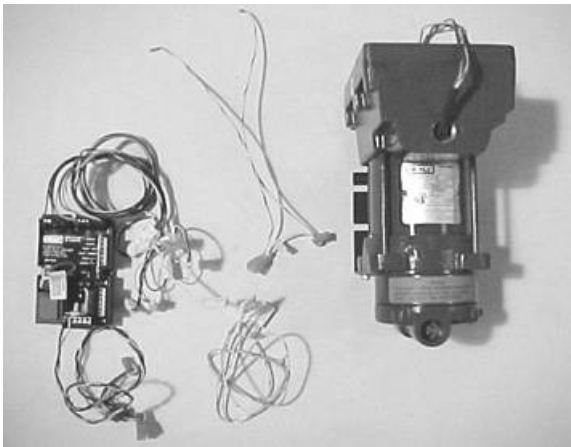


Photo A

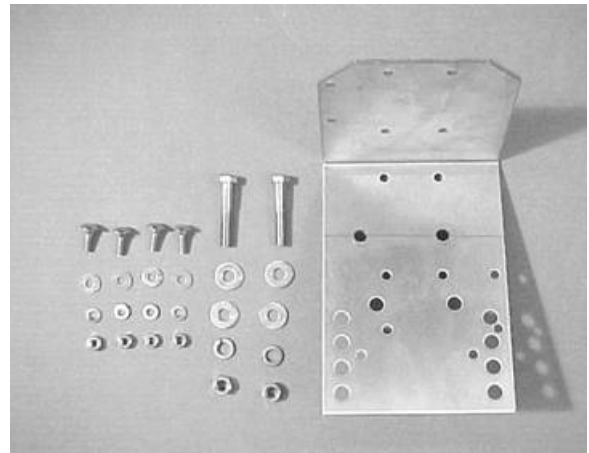


Photo B

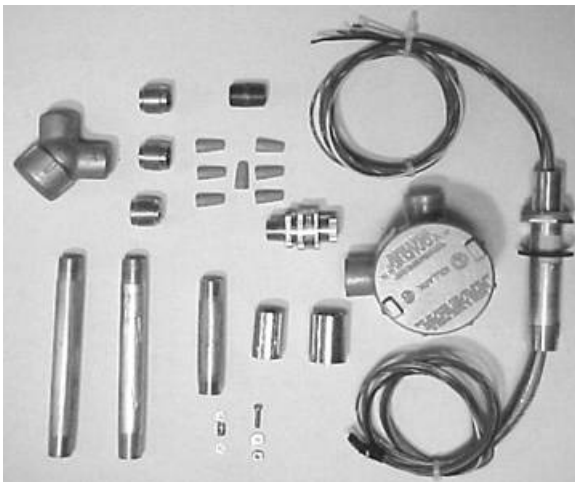


Photo C



Photo D

### **HARDWARE KIT Z082H: (See Photo B)**

- 2 3/8 - 16 x 2" bolts with nuts and washers
- 1 1310 Mounting bracket
- 4 1/4 - 20 bolts, washers, lock washers and nuts

### **ELECTRICAL KIT Z082E: (See Photo C)**

- 1 Current change label (p/n 1405)
- 7 Wire nuts
- 1 8-32 x 5/8" machine screw, washer and nut
- 1 #1316 potted conduit nipple
- 1 #8 ring tong terminal and star washer
- 1 Notice label (p/n 1406)
- 1 UL Listed label (p/n 1410)
- 1 1/2" electrical union
- 3 1/2" x 3/4" electrical reducing bushing
- 1 Explosion proof junction box
- 1 1/2" capped elbow (electrical)
- 1 3/4" coupling (electrical)
- 2 1/2" x 7" electrical nipple
- 1 1/2" x 4" electrical nipple
- 1 1/2" electrical close nipple
- 1 1/2" electrical coupling

### **VAPOR KIT Z082V: Vapor ready only (See Photo D) See photo U for Z083V VaporVac™ Kit**

- 2 1/2 " NPT X 5/8" flair straight fittings
- 3' 5/8" OD copper tube, type 'L'
- 1 1" x 1/2 " reducing bushing
- 2 1/2 " close nipple
- 1 1/2 " x 1/2 " x 1/2 " tee
- 1 1/2" x 1/4" reducing bushing
- 1 1/2 " ball valve
- 1 1/4 " pipe plug
- 4 5/8" flare nuts
- 1 1/2" street elbow

- 2 1/2" NPT x 5/8" flair elbow fitting
- 1 1" x 1/2" bell reducer

**MATERIALS SUPPLIED BY INSTALLER:**

- Thread Sealing Compound – non-Setting, UL Classified for use on all tapered threads, non-electrical, plumbing fittings.
- Oil and gasoline compatible PTFE tape

**5. TOOLS REQUIRED:**

- 1/2" or 3/8" ratchet set w/ sockets 1/4" through 9/16" + 3" extension
- 9" lineman's pliers
- Assorted open end wrenches 1/4" through 3/4"
- Wire cutters/strippers 18 AWG and 26 AWG
- Assorted screwdrivers (flat blade-one must be 1/8" wide and Phillips)
- 5/8" & 1/2" copper tube bending tool
- 5/8" & 1/2" copper tube flaring tool
- Copper tubing cutter
- Electrical multi-Oeter
- Small hand brush (1-1/2" wide, for clearing chips)
- 12" adjustable wrench
- 10" pipe wrench
- Tape measure
- Allen wrenches

**6. DISPENSER ACCESS:**

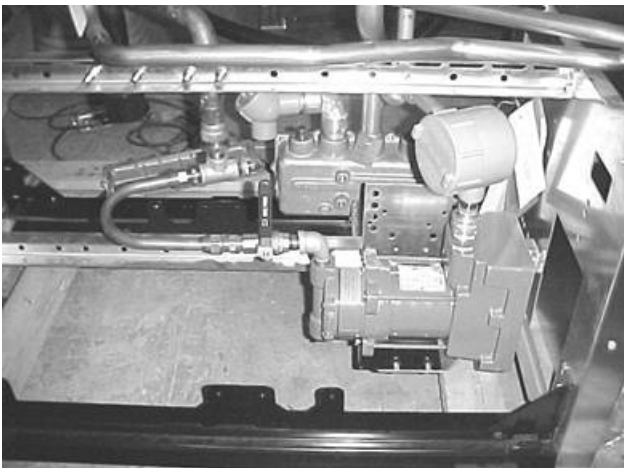
- Secure Dispenser Access keys from Station Management.
- Remove lower cabinet panels and open upper access doors.
- Lock-out and tag-out all electrical power to dispenser being modified.

Refer to manufacturer's manual to determine 'A' side and 'B' side of dispenser.

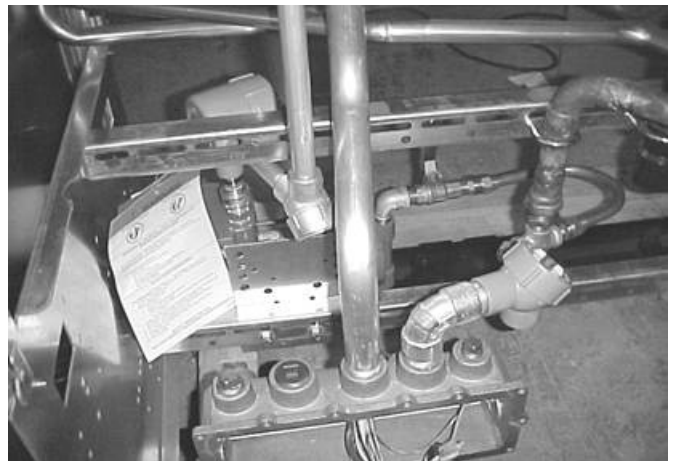
**7. SURVEY – Scope of Work: *Perform this step before beginning steps 8 thru 12.***

Read and familiarize yourself with the theory of operations sheet and wiring instructions for the VP1000 Vapor Pump. The installation of the pump is on a metal bracket mounted to the center cross bar, behind the main electrical 'J' box, see photo E. This is the opposite side that the 1" vapor tube terminates from the upper vapor manifold, see photo F. From this survey, you will have an indication of where the vapor plumbing fittings need to go. In the electronics compartment, locate the sealed electrical nipple coming up from the hydraulics compartment, near the center of the dispenser. In this area, there are a series of electrical knockouts, one of which needs to be removed to install the 1316 sealed nipple assembly for the Healy VP1000 electrical connections. The electrical interface module will be mounted on the cross rail near the place where the sealed nipples come from below. See Section 11.

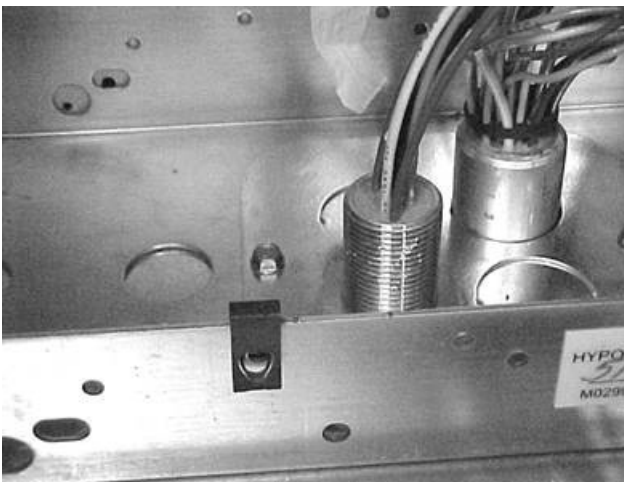
**CAUTION: ALL POWER TO DISPENSER UNDER MODIFICATION SHOULD BE COMPLETELY DISCONNECTED AND CAPPED OFF AT JUNCTION BOX TO AVOID UNINTENTIONAL FEEDBACK FROM OTHER DISPENSERS!!**



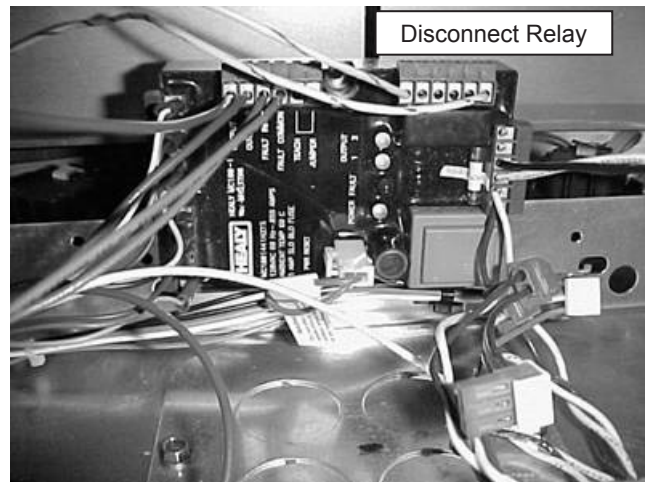
**Photo E**



**Photo F**



**Photo G**



**Photo H**



## 8. INSTALLING THE HEALY VP1000 SYSTEM:

- Get the VP1000 mounting bracket and install to the center cross rail from the non- electrical J-box side, using two 3/8 – 16 x 2” bolts, nuts, flat and lock washers. Using the 2nd and 3rd holes from the right on the cross rail, select the bolt holes in the bracket that places the shelf of the bracket about 2” below the bottom of the cross rail. This position assures that the plumbing is self-draining and avoids traps in the vapor line. Do not completely tighten the hardware, see photo J.

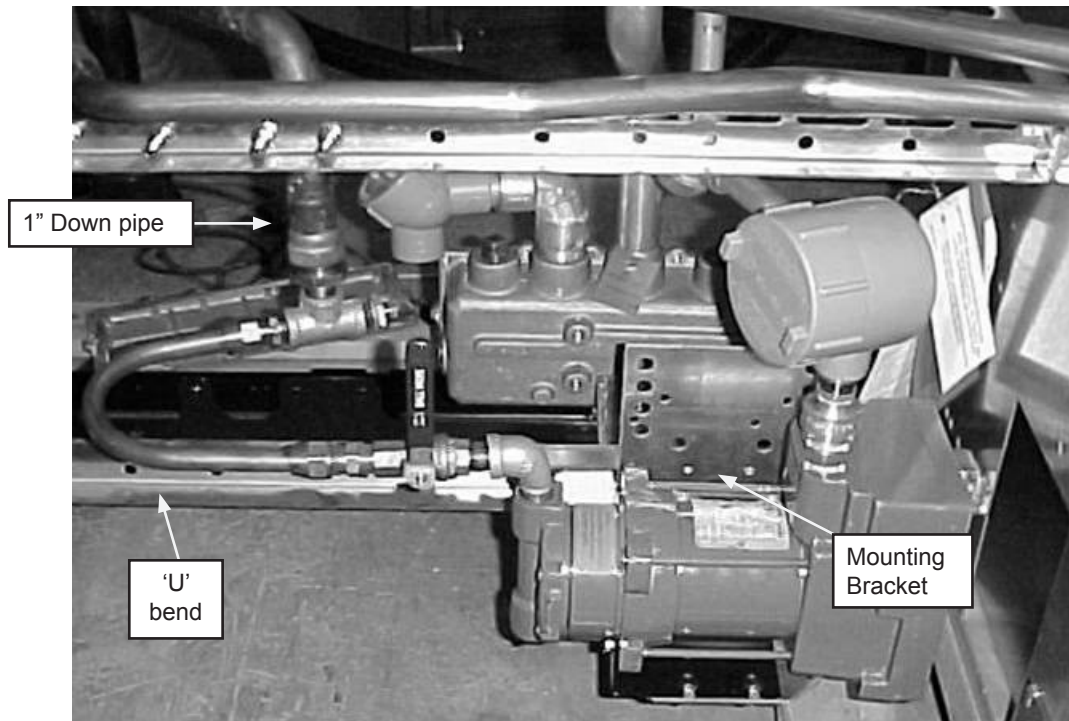


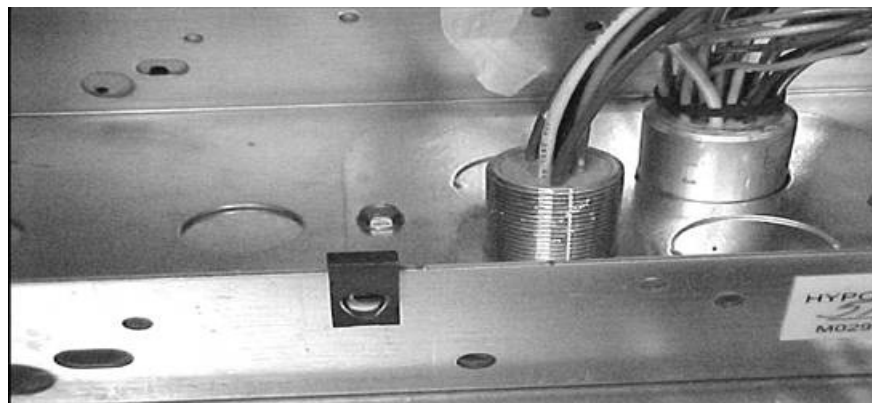
Photo J

- Get the vapor pump and install a 1/2” NPT street elbow fitting into the ‘IN’ port and a 5/8” flare x 1/2” NPT elbow in the ‘OUT’ port using tape, not pipe dope. Looking at the face of the pump, completely tighten both fittings so they are facing directly out from the front of the pump.
- Position the pump on top of the mounting bracket with the fittings facing in the direction shown in photo J. Slide the pump to allow for matching the location of holes in the pump and mounting bracket.
- Loosely secure the pump to the bracket using the four 1/4” bolts, nuts, flat and lock washers. (Final tightening is done after the electrical is completely installed.)
- Using tape, install a 1/2” close nipple into the street elbow. To this, install the 1/2” ball valve and one of the 5/8” flare x 1/2” NPT straight fittings. Final tighten such that the handle on the ball valve points upward when the valve is closed. □ Install and final tighten a 1” x 1/2” reducer bushing into the 1” vapor down pipe.
- To the 1/2” tee, install a 1/2” x 1/4” reducer bushing into one of the end ‘run’ openings, then install a 1/4” pipe plug into the bushing- final tighten. Install a 5/8” flare x 1/2” NPT straight fitting into the other end ‘run’ opening and tighten. Install a 1/2” close nipple into the branch opening.

- ❑ Install the above into the 1/2 “ reducer fitting on the vapor down pipe, final tightening so the flare fitting faces away from the VP1000 pump, see photo J.
- ❑ Final connection from the pump to the down pipe is done after the electrical piping has been completed.

## 9. INSTALLING THE SEALED NIPPLE ASSEMBLY: (See Photo G)

**NOTICE:** THE INTERFACE MODULE THAT IS SUPPLIED HAS A HARNESS ATTACHED AND A WIRING PLUG FOR THE AC CONNECTIONS. ALSO SUPPLIED IS THE SEALED NIPPLE ASSEMBLY (1316) THAT MUST BE USED BETWEEN THE ELECTRONICS COMPARTMENT AND THE DIVISION 1 AREA (THE SPACE BELOW AND OUTSIDE THE ELECTRONICS COMPARTMENT).



**Photo G**

- ❑ In the electronics compartment, locate the sealed nipple that contains the dispenser wiring. Notice that there are 2 or 3 blank knockouts next to the existing nipple. Diagonally, to the left and below the existing nipple, knock out one pre-punched filler piece. (Punch only the same one on each plate. Do not leave any empty holes).
- ❑ Remove the two hex head screws holding the knock out panel in place. The panel cannot be removed, but can be raised to allow access to the lower vapor barrier panel for removing the knockout in that piece and also allows access for securing the nuts of the sealed nipple assembly.
- ❑ Get the 1316 sealed nipple assembly and carefully remove the first nut and washer over the wires. Tighten the other nut down on the nipple as far as it will go leaving the washer on top of the nut.
- ❑ Run wires (from the short threaded end of sealed nipple) down from electronics cabinet through lower knockout only.
- ❑ Push the rubber washer down on the sealed nipple approximately 2”. Run wires (from the long threaded end of sealed nipple) and nipple up through the upper knockout plate. Install the washer and nut that was removed above and tighten the nipple securely to the plate.
- ❑ Reposition the upper knockout plate to its original location and secure with the previously removed screws. Check to be sure the rubber washer is seated on the lower panel.



- ❑ Do not use pipe dope or tape on the following fittings and be sure there is at least five full threads of engagement of the fittings in their respective couplings.
- ❑ To the bottom of the sealed nipple assembly installed above, install a 3/4" electrical coupling and then, a 3/4" x 1/2" reducing bushing into the coupling.
- ❑ Install one of the 1/2" x 7" electrical nipples to the reducing bushing above then the 1/2" coupling and then the other 1/2" x 7" electrical nipple.
- ❑ Get the 1/2" capped elbow and remove the cover. Thread the wires from above through one of the elbow hubs and completely tighten so that the open hub of the elbow faces the electrical wires on top of the motor.
- ❑ Get the 4" long conduit and install in the remaining opening in the capped elbow. (Do not pull wires at this time).
- ❑ Install 3/4" x 1/2" reducing bushings into each opening on the electrical junction box supplied.
- ❑ Install the J-box to the 4" nipple as shown in Photo J. This should position the cover opening to your left and the remaining opening on the J-box approximately over the electrical wires on the pump. The motor or bracket position may need to be adjusted to attain this alignment.
- ❑ At the VP1000, get and install the threaded half of the 1/2" electrical union over the wires coming from the motor. Do not use pipe dope on these fittings and be sure there is at least five full threads of engagement of the fittings in their respective couplings.
- ❑ Thread a 1/2" electrical close nipple into the remaining half of the electrical union and install into the remaining opening of the J-box.
- ❑ Carefully feed the motor wires into the split union pieces and into the "J" box until the two halves of the union can be slid together and secure.
- ❑ Completely tighten the hardware on both the pump and the bracket.
- ❑ Carefully feed the wires from the capped elbow into the J-box, pull wires loosely until the cover can be replaced on the capped elbow. Replace cover.
- ❑ In the "J" box, leave about 6" of wire on both the wires coming from the motor and from the sealed nipple, cut off excess wire and strip approximately 1/2" of insulation from all wires.
- ❑ Use wire nuts to join the wires, color for color, together. There may be some extra wires in some sealed nipples, cap these off and dress aside.
- ❑ Replace the cover on the junction box.
- ❑ Bend a broad 'U' into a piece of 5/8" copper tube and carefully fit between the flare fittings between the VP1000 and the vapor down-pipe. One of the 'legs' should be at least 6" long before cutting and installing the nuts and flaring the ends. This installation provides a flexible cushion in the tubing, see photos K & L below.
- ❑ Note: The discharge piping from the 5/8" flare elbow attached to the out port of the VP1000 is left up to the installer. There is extra 5/8 tubing, flare elbow and a bell reducer to help with the final installation.

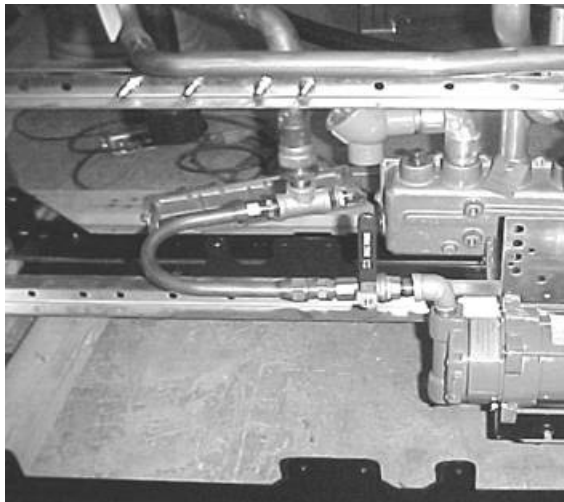


Photo K

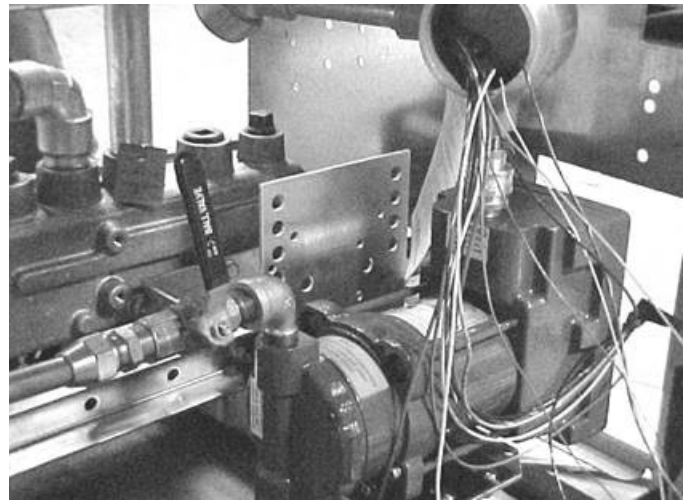


Photo L

## 10. WIRING INSIDE THE ELECTRONICS COMPARTMENT: (SEE PHOTOS H, M & N)

- ❑ Secure the prewired Interface Module to the inside, between the two cross rails in the electronics compartment using the 8-32 screw, nut and washer supplied, see photo H.
- ❑ The wiring kit contains one jumper assembly. To install the jumper assembly, connect the stripped wires, one to terminal 1 of the solenoid disconnect relay, see photo H, and the other to terminal 6 of the same terminal block.
- ❑ Identify the P1200 location on the valve converter board and remove the connector from the socket on the board. Insert this connector into the mating socket on the jumper assembly. Insert the matching plug on the cable into the J1200 location on the board, see photos M & N.

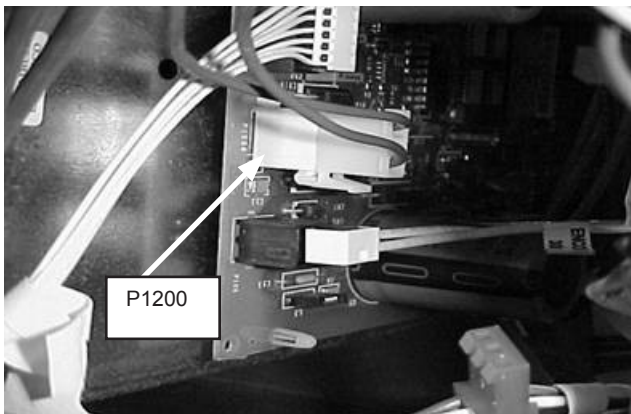


Photo M (300)

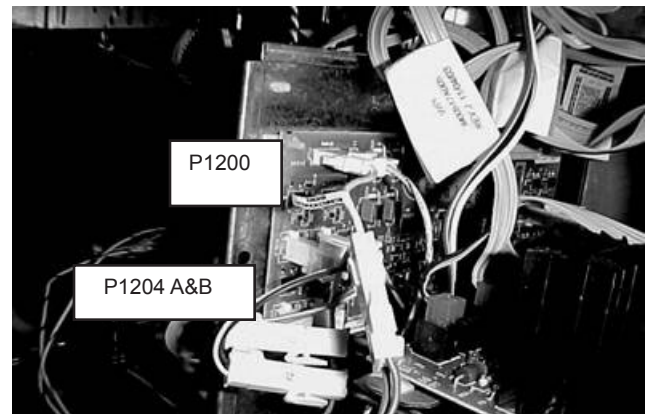
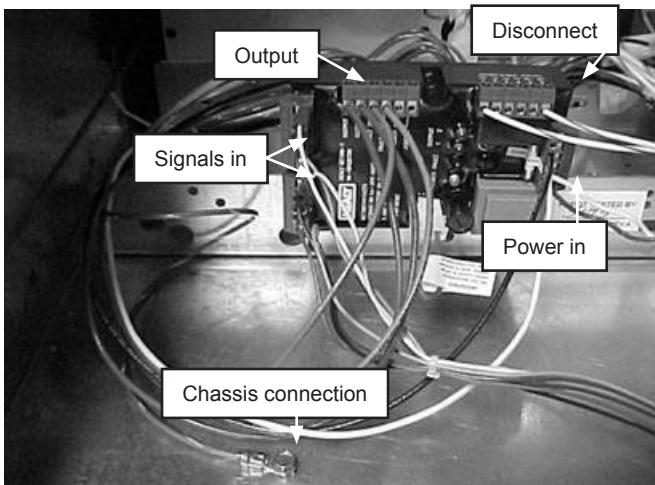


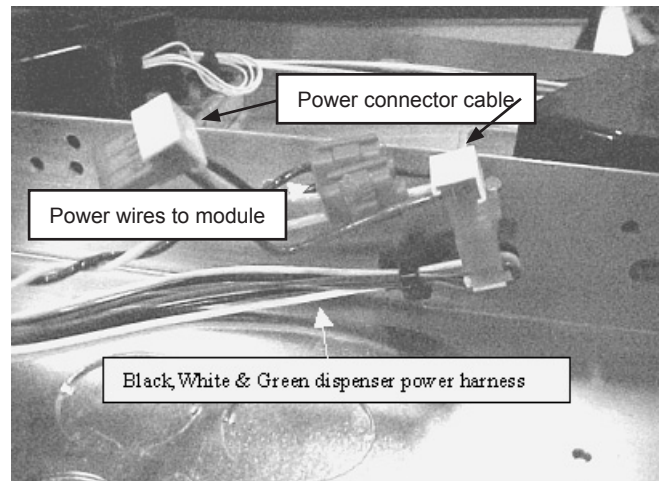
Photo N (500)

- ❑ **Using the cable harness attached to the module, identify and segregate the “A” side and “B” side connectors.** The valve board connections are arranged by product, so it is important to be sure the “A’s” and “B’s” are connected to the appropriate sockets on the board. Connect the ‘signal’ inputs A1, 2, 3 and B1, 2, 3 male/female connectors on the cable to the appropriate locations on the valve converter board. Be sure to keep the “A’s” and “B’s” together as there are “A’s” and “B’s” on both sides of the valve converter board. Note only connect the module to active gasoline products – **do not connect to diesel or other unused valve connection points.**

- The seven (7) wires from the sealed nipple assembly are connected as follows:
  - Red (either one) connected to 'OUTPUT 1' on output terminal board
  - Red (other one) connected to 'OUTPUT 2' on output terminal board
  - Purple connected to 'FAULT' on output terminal board
  - Orange connected to 'FAULT COMMON' on output terminal board
  - Green – connect the ring lug supplied and then attach to chassis, see photo O.
  - Black – connect to Motor terminal on power input terminal strip
  - White – connect to Neutral on input terminal strip
- The black wire on the power jumper is connected to 'Power In' and the white wire is connected to 'Neutral' on the input terminal strip. The orange connector on the other end of the black and white pair is connected to any available power plug on the dispenser harness. The dispenser power harness is composed of a black, white and green wires running together along the center rail and has orange, 3-pin connectors that will mate with the power wire from the MC100-1 module, see photo P.



**Photo O**



**Photo P**

## 11. CONNECTING HEALY SYSTEMS DISPENSING EQUIPMENT

- Completing the connection of Healy Systems dispensing equipment requires the installation of Healy Systems Phase II dispenser adaptors, hoses and nozzles (Hanging Hardware).
- If applicable, remove existing non-Healy hanging hardware (from the dispenser product outlet adaptor, to and including the nozzles).
  - Vapor ready dispensers may require a Healy Systems adaptor to make the hose threads compatible with other Healy Systems equipment. Install necessary adaptor following instructions packed with the adaptor. Various adaptors and pigtails are available, depending on how the dispenser is configured: M34 metric (Healy designation F3 or S3) or balance ready (Healy designation S4).
  - Healy Vapor Recovery Hoses are available in various lengths to satisfy local ordinances and still provide “far side” fueling capability. Install these following instructions contained on the shipping box.

- Breakaways are required: Install either Model 8701-VV breakaway or Model 807 swivel breakaway; install using the instructions supplied with the unit.
- The Healy Systems nozzle Model 900 (EVR) series is the only nozzle necessary to complete the upgrade. **Check to be sure the nozzle hook is mounted in the position shown for Healy nozzles in section 16.** Be sure to check for proper fit in the nozzle holster and that the nozzle can be locked in the off position. Also, be sure that when the nozzle is locked, that the dispenser cannot be activated from the locked position.

## 12. VP1000 THEORY OF OPERATION

The Healy Systems VP1000 is a self-contained rotary vane pump, designed for gasoline vapor recovery utilizing various parts of the Healy System Vapor Recovery product line. It is intended for use by either OEM dispenser/pump manufacturers or as an after market add-on to make existing equipment compatible with Healy System technology. In order to convert to 'others' equipment, an electronic interface is required to adapt the targeted pump/dispenser to the new vapor recovery equipment. The interface senses when authorization to dispense has been given and sends signals to the motor to operate at a low speed for one hose, or a higher speed for two hoses. It also functions to shut off the pump/dispenser if it senses that the vapor pump is not operating properly. The vacuum is regulated at a level sufficient to clear liquid gasoline from the vapor path in MPD applications. The Healy nozzle controls the actual amount of vapors withdrawn, itself, in response to the liquid gasoline flow rate.

### MOTOR SPECIFICATIONS

Horsepower	1/8
Voltage	120VAC

### INTERFACE SPECIFICATIONS

Input voltage	120 VAC
Relay current capacity	5A AC
Input signals	AC and DC voltages up to 130 VAC max
Motor Input signal	5 VDC @ 20 Hz 50% Duty Cycle

### 13. TESTING THE SYSTEM:

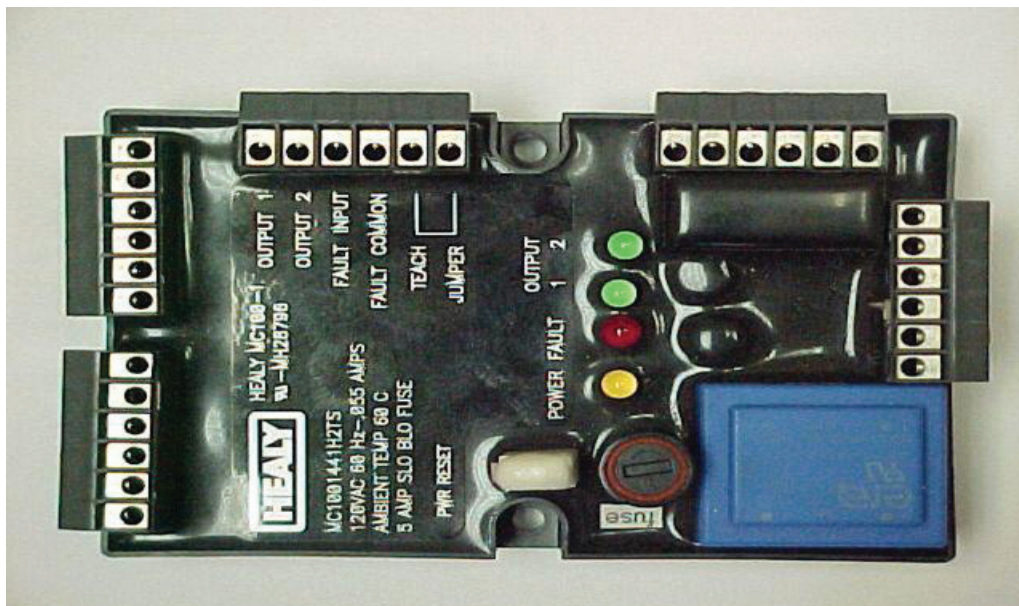
- Carefully review all work completed, being sure all mechanical joints are thoroughly tightened and electrical connections sealed.
- Open the product crash valves and restore power to the dispenser.
- With the power on, but no nozzles authorized, the VP1000 should not be running (unless the ambient temperature is below 40°F), but the power LED (yellow) should be energized on the interface module.
- Authorize one handle and the vacuum system should activate when the gasoline flow control valve is engaged. Repeat for all other nozzles, individually testing each nozzle on each side of dispenser. With each authorization, one of the green LED's on the interface module should illuminate and the VP1000 activate.
- Note: For unihose dispensers, conduct individual tests for each product grade on each side of the dispenser to ensure that the same LED activates for all grades on the same side. If the other LED activates, wiring needs to be corrected.
- Authorize one nozzle, listen to the speed of the VP1000. With one nozzle activated, the speed will be slower than if a nozzle on each side is activated. Activate a nozzle on the other side of the dispenser and listen for the speed to change.
- To test the tightness of the vapor plumbing installed on the suction side of the system requires a 0-100" water column gauge. Connect the gauge into the 1/4" test port of the adaptor tee installed earlier in section 8 Photo J. Continue by following and completing the START-UP / NEW INSTALLATION/ WARRANTY/ ANNUAL TESTING FORM.



## 14. TROUBLESHOOTING THE VP1000:

- ❑ Use extreme care and caution when performing the tests listed below. If 120 VAC is accidentally applied to the fault or DC terminals, the module will be destroyed.
- ❑ With power applied to the dispenser, but no products authorized, there should be 120 VAC between neutral and 120 VAC on the module terminal strip.
- ❑ As above, with any product authorized, there should be single speed power applied to the VP1000. Verify this by checking for 2-3 VDC from OUTPUT 1 (RED WIRE) to FAULT COMMON (ORANGE WIRE), (or from OUTPUT 2 TO FAULT COMMON) also; one GREEN LED should be illuminated. With a second product authorized on the opposite side of the dispenser i.e. one product on each side, the motor should operate at higher speed and there should be 2-3 VDC on both output 1 and 2 (to fault common) and both GREEN LED's should be illuminated.
- ❑ With the pump running, a fault can be simulated by shorting, with a jumper wire, the "FAULT INPUT" (purple wire) to FAULT COMMON (orange). This should cause the motor to shut off, the solenoid valves to lose power and the dispenser to shut down. Also, as long as the short is maintained, the red LED will be illuminated. Removing the short will not automatically reset the module. To reset the module, remove the short, remove power to the dispenser for twenty seconds and restore power. The module should now be reset and the red led extinguished. This can also be accomplished by using the power reset (PWR RESET) on the module.
- ❑ If diagnosing a problem where the LED is already illuminated, a steady light indicates a low current condition, therefore expect a vane or rotor problem. If the LED is blinking, that indicates a high current condition and would expect to find a jammed rotor or vapor line flooded with product. See Start-up/ New Installation/ Warranty/ Annual Testing Form.
- ❑ The electronics of the motor will make three attempts to have a successful start of the motor. If it detects a problem, on the fourth unsuccessful start, it will short the fault line to signal minus (DC-) and shut down the electronics.

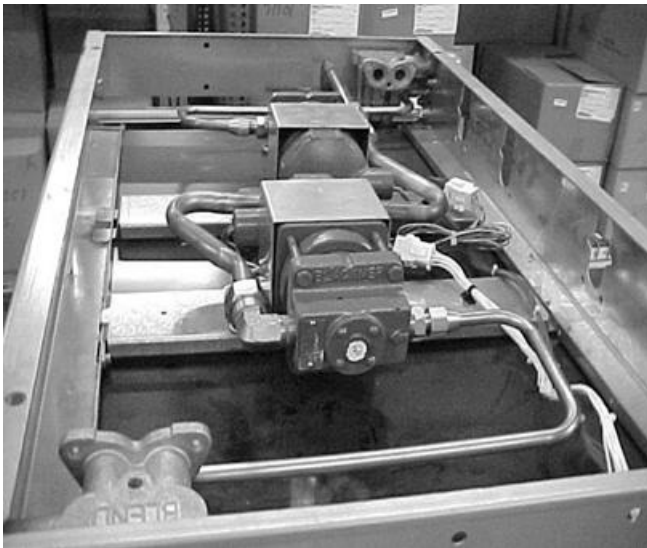
### MC100 Interface Module



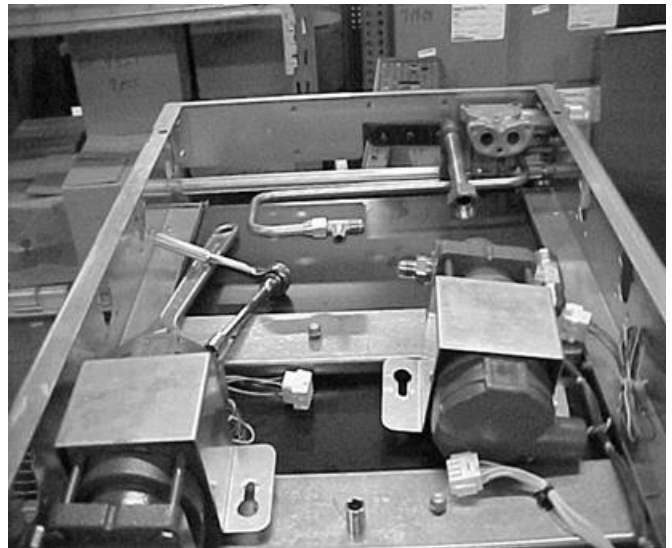
## 15. VAPORVAC™ REMOVAL:

Described below are the steps necessary to remove a VaporVac™ and re-plumb the vapor lines to install the Healy VP1000 series vapor assist recovery system.

- ❑ Removal of the VaporVac pumps requires the top cover of the dispenser be removed. From the top of the cover, remove the four corner bolts and lifting eyes if present, along with various washers. Remove the cover. Save hardware for reinstallation.
- ❑ With the top removed, notice the 'loose' cross rails that the top cover bolts were screwed in to – remove these rails and save for reinstallation after conversion.
- ❑ Be sure all electrical power to the dispenser has been disconnected and disconnect the electrical connections going to each pump.
- ❑ Loosen and disconnect all the vapor pipes from both VAC pumps. Do not remove the vapor pipes from the product outlets, see photos Q and R.
- ❑ From one of the pumps, remove the 3/4" NPT X 1" flare elbow fitting and save for use below. Remove the two brackets and motors.

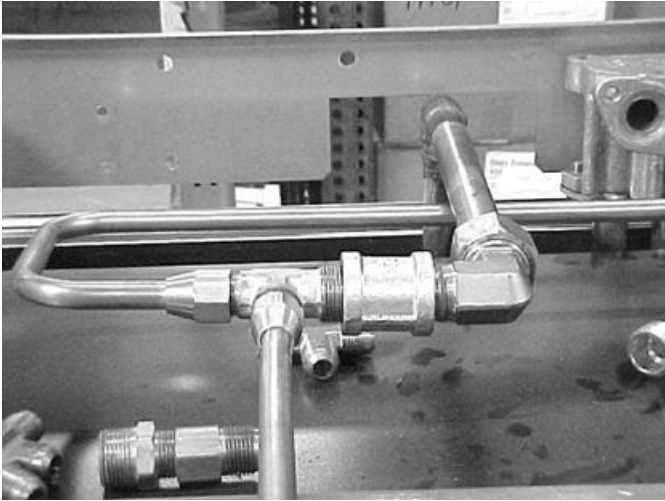


**Photo Q**

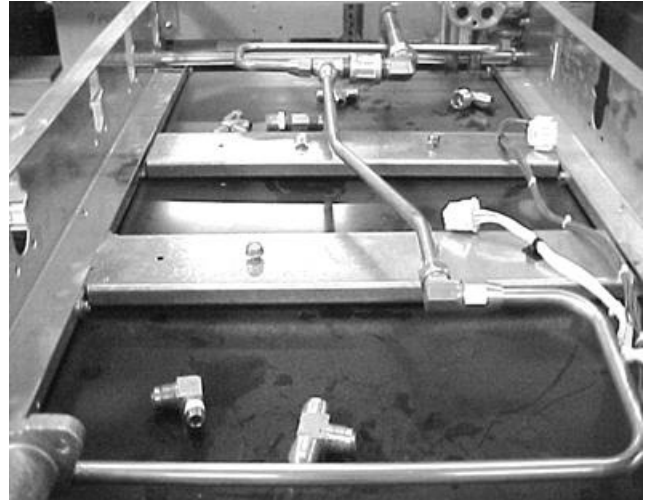


**Photo R**

- ❑ Into the 3/4" x 1" elbow that was removed above, attach the 3/4" x 1/2" bell reducer supplied in place of the 3/4" coupling shown in Photo S and then install the 1/2" NPT x 1/2" x 1/2" flare tee using tape. Tighten with the branch pointing opposite the flare connection, and then attach the flare fitting to the vapor down pipe fitting, see photo S.
- ❑ Connect the loose vapor tube fitting from the dispenser outlet to the run flare position on the tee. Cut and flare a piece of 1/2" copper tube suitable to connect the other vapor connection to the tee using the 1/2" x 1/2" flare elbow fitting supplied, see photo T.



**Photo S**



**Photo T**

- ❑ Electrical wiring and lower cabinet plumbing are the same for Balance or VaporVac™.
- ❑ Deprogram the VaporVac™ system using the “Electronically Disabling the VaporVac System” instruction sheet, enclosed in the Z083V VaporVac™ Kit.
- ❑ After testing, reinstall the cross rails, top cover and hardware removed earlier.

## Z083V VaporVac™ Kit

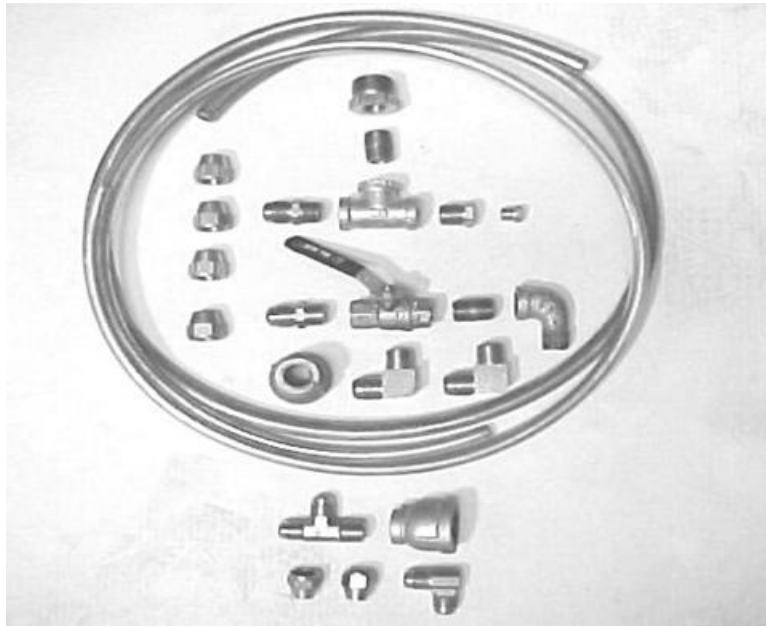


Photo U

### VAPOR KIT Z083V: for VaporVac™ Kit (See Photo U)

- 1 1/2" NPT X 5/8" flair straight fittings
- 3' 5/8" OD copper tube, type 'L'
- 1 1" x 1/2" reducing bushing
- 2 1/2" close nipple
- 1 1/2" x 1/2" x 1/2" tee
- 1 1/2" NPT x 1/4" reducing bushing
- 1 1/2" ball valve
- 1 1/4" pipe plug
- 4 5/8" flare nuts
- 1 1/2" street elbow
- 2 1/2" NPT x 5/8" flare elbow
- 1 1" x 1/2" bell reducer
- 1 1/2" flare x 1/2" flare x 1/2" NPT tee
- 1 3/4" x 1/2" bell reducer
- 1 1/2" x 1/2" flare elbow
- 2 1/2" flare nuts
- 2' 1/2" OD copper tube, type 'L'
- 1 "Electronically Disabling the VaporVac System" instruction sheet

## 16. GILBARCO ENCORE NOZZLE HOOK ADJUSTMENT

This document details how to adjust Gilbarco Encore dispensing unit nozzle hooks to accommodate various manufacturers' nozzles.

Required tools: drill, 7/32" or # 22 drill bit, 1/4" square-tip driver, 7 mm metric hex nut driver or socket, 3/8" nut driver or socket.

NOTE: AC or battery powered drills must not be used at the dispensing unit because of the danger of explosion or fire due to the presence of hazardous vapors.

### Step One: Preparation.

1. Notify site personnel of work to be performed.
2. Secure work area.
3. Isolate dispensing unit from point-of-sale or pump controller.
4. Close shear valves.
5. Remove nozzle(s) from nozzle boot(s) and place on ground.

### Step Two: Remove nozzle boot(s) from dispensing unit.

1. Loosen two nozzle boot mounting screws. (See figure 1) using 1/4" square tip driver. Note: Save nozzle boot mounting screws for use later.
2. Remove nozzle boot from door by pulling toward you.

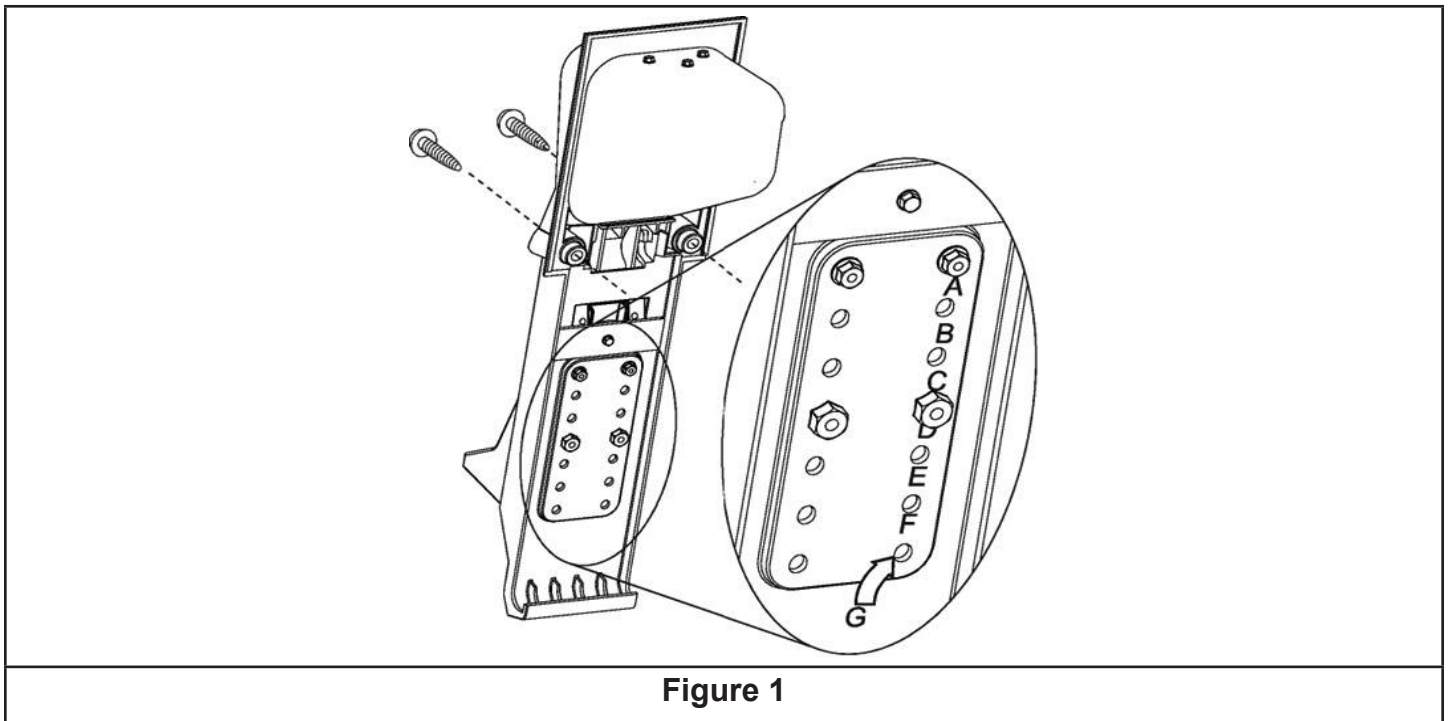


Figure 1

### Step Three: Remove nozzle hook from nozzle boot.

1. Place nozzle boot face down on work surface covered with soft cloth to protect nozzle boot face.
2. See figure 1 to identify existing nozzle hook retaining screw and nut locations. Identifying marks are located under right hand row of indented hole locations. Standard nozzle hook locations are A & D.



3. Use 7mm nut driver or socket to remove two upper hex head screws.
4. Use 3/8" nut driver or socket to remove two nuts from lower carriage bolts.
5. Remove nozzle hook and carriage bolts from nozzle boot. Save hex head screws, carriage bolts and nuts for use later.

**Step Four: Determine Nozzle Hook Position**

1. Determine new nozzle hook position using chart below as guide to select new hole positions. See Figure 1 to identify nozzle hook retaining screws and nuts locations. Identifying marks are located under right hand row of indented hole locations.

Nozzle Type	Upper Hex Head Screw Location	Lower Carriage Bolt & Nut Location
Standard Factory Location All Non-Vapor	A	D
VaporVac - OPW, Husky, Emco Wheaton	A	D
VaporVac - Catlow, Richards	B	E
Healy System	C	F
Balance - Husky Short	A	D
Balance - Husky Long, Emco Wheaton Long	E	Unmarked. Use nozzle hook carriage bolt holes as drill guide.
Balance - OPW Long	Bottom hole set ("G" on Figure 1)	Unmarked. Used nozzle hook carriage bolt holes as drill guide.

**Step Five: Drill New Holes.**

1. Use 7/32" or # 22 drill bit to drill new holes as needed.
2. When locations "E" or "G" are used by the upper hex head screws, the lower carriage bolt and nut hole set are unmarked. Temporarily mount the nozzle hook with the upper hex head screws in location "E" or "G" (as determined by chart) then use the nozzle hook carriage bolt holes as a drilling guide for the unmarked hole set.
3. Once holes are drilled, remove nozzle hook and clean up debris around hole set.

**Step Six: Assemble nozzle hook to nozzle boot.**

1. Reverse Step Three to assemble nozzle hook to nozzle boot.

**Step Seven: Test nozzle hook adjustment using new nozzle.**

1. Hold nozzle boot upright and insert nozzle over nozzle hook and into boot. Wiggle boot to verify the nozzle does not slip out of position.

**Step Eight: Install nozzle boot(s) onto dispensing unit.**


1. Reverse Step Two and install the adjusted nozzle boot onto the dispensing unit.

**Step Nine: Re-insert Nozzles into the boot.**

## 17. VP1000 VANE & ROTOR SERVICE & REPLACEMENT GUIDE

**Caution**  **Disconnect power before beginning service.**

1. The work area **must** be clean and have sufficient lighting.
2. Disconnect the vapor piping connected to the **IN** and **OUT** ports of the VP1000 cover assembly.
3. Remove the four Allen head screws and lock washers that secure the pump cover assembly to the pump housing and remove the cover carefully.

**Caution**  **Use a spill cloth when removing the cover, as there may be some gasoline inside the pump cavity.**

4. Carefully turn the rotor assembly by hand until the shaft key notch is at the 12 o'clock position. (See Figures)
5. Remove the rotor, vanes and shaft key from the pump housing.

**Note:** Place your hand or a container under the rotor while removing. Do not use any sharp objects that would scratch the surfaces of the pump cavity, pump shaft, rotor, or vanes.

6. Rotate the shaft by hand. If the shaft does not rotate freely, the entire vacuum pump needs replacement (p/n VP1000-5 or RVP1000-5).
7. If the rotor and vanes are cracked, chipped, excessively worn or excessively dirty, the rotor and vanes should be replaced because cleaning will not remedy these conditions (p/n VP1000VRC-G, VP1000VRC-P or VP1000VRC).
8. If there is no visible damage, use a lint-free cloth with isopropyl alcohol to clean the rotor and vanes.
9. Using a lint-free cloth with isopropyl alcohol, thoroughly clean: the inside of the pump ring and rear of the pump cavity, the rotor shaft, and the inside of the pump cover.
10. Reposition the shaft (if necessary) so that the shaft key notch is in the 12 o'clock position. Install the cleaned original or new shaft key onto the shaft.
11. Carefully install the cleaned original or new rotor onto the shaft followed by the cleaned original or new vanes into the rotor.

**Note:** The rotor assembly should slide on to the shaft easily, without excessive force. (Rotors and vanes are reversible)

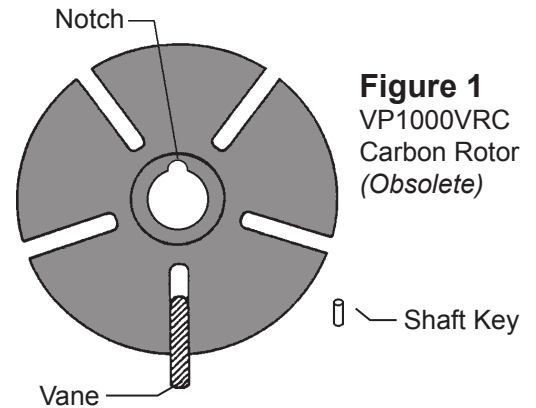
12. Lightly lubricate and install the new O-Ring for the pump housing.

**Note:** Do not allow any lubricant to get inside the pump housing.

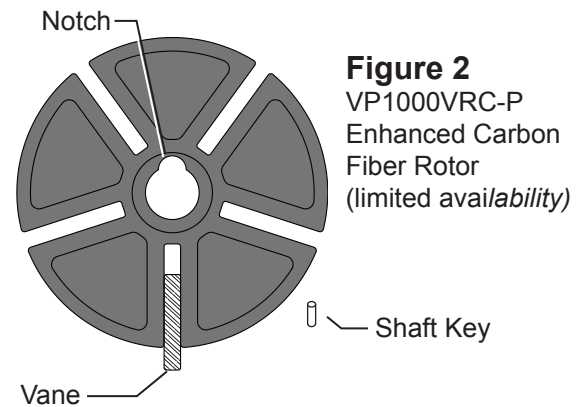
13. Install the pump cover using the four Allen head screws and lock washers removed in step 3 and cross tighten.

**Note:** Use caution when sliding the pump cover over the O-Ring seal to prevent cutting or tearing.

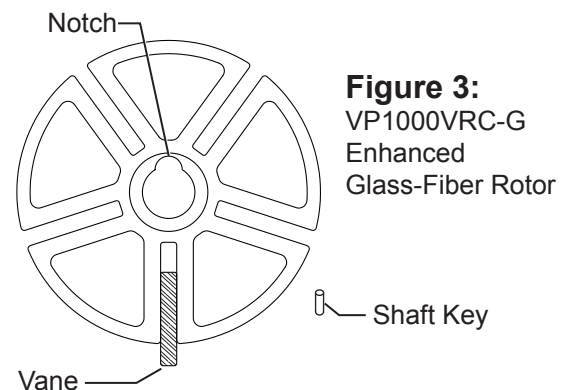
14. Re-connect the vapor piping to the **IN** and **OUT** ports of the pump cover assembly that was removed in Step 2.
15. Re-apply power. Test for normal operation. (See VP1000 Vacuum Performance Test Procedure)



**Figure 1**  
VP1000VRC  
Carbon Rotor  
(Obsolete)



**Figure 2**  
VP1000VRC-P  
Enhanced Carbon  
Fiber Rotor  
(limited availability)



**Figure 3:**  
VP1000VRC-G  
Enhanced  
Glass-Fiber Rotor

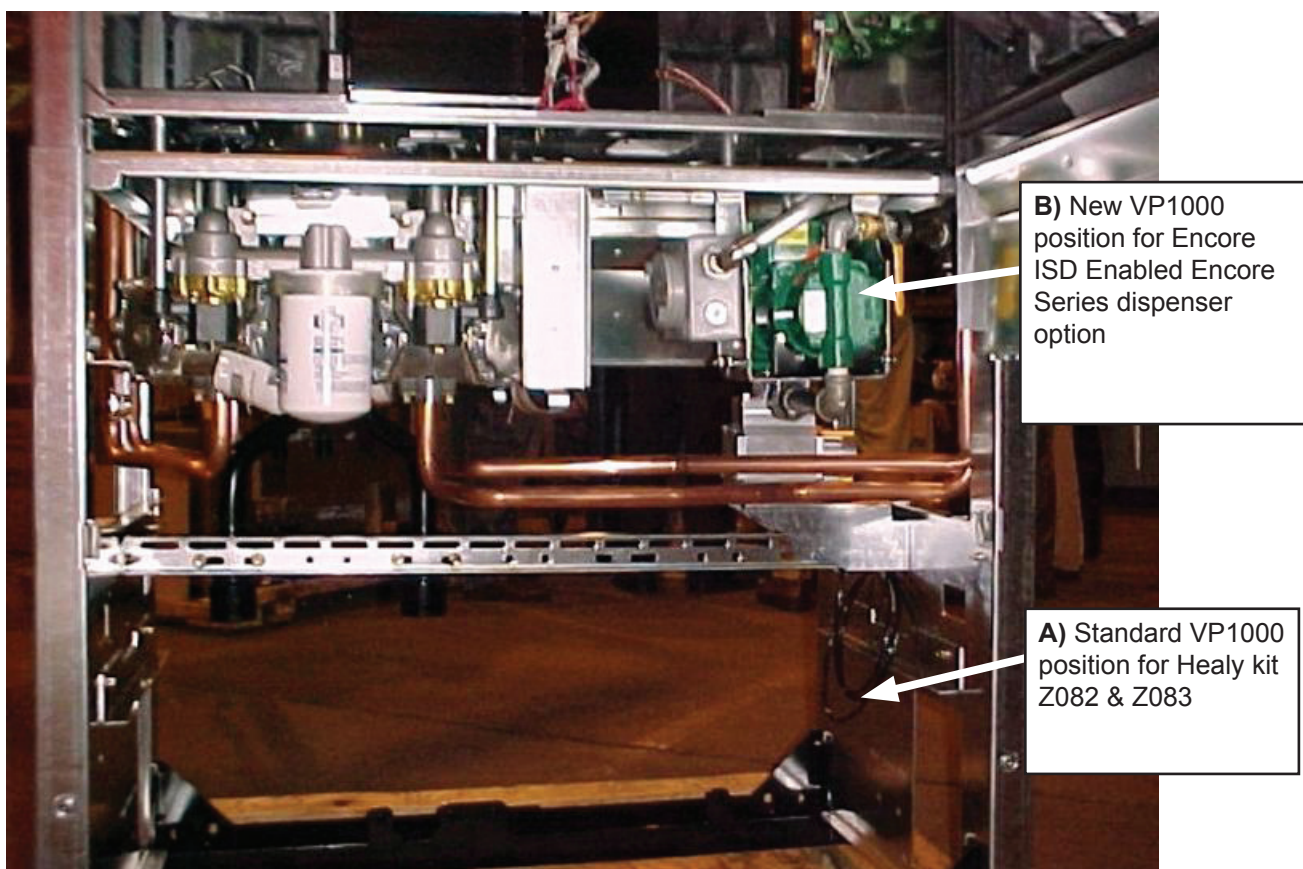
## 18. LOCATION CHANGE OF HEALY VP1000 ON ENCORE SERIES ISD ENABLED DISPENSERS

### 1. DESCRIPTION OF NEW VP1000 POSITION

To accommodate room for the ISD vapor flow meter and facilitate proper connection above a vapor line shear valve, the Healy VP1000 Vacuum Pump has been moved up approximately 20 inches in the hydraulics compartment from position A to position B as shown in Figure 1 below.

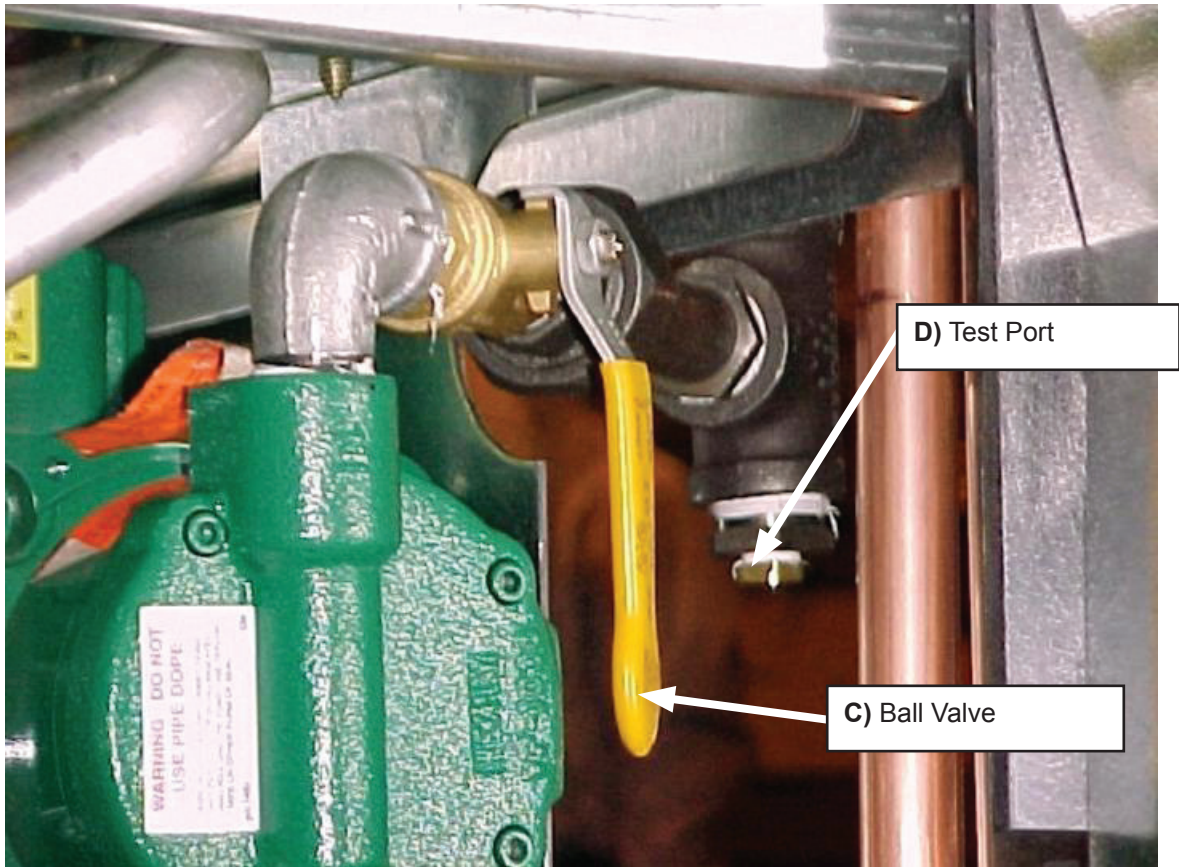
**Note:** Encore Series Dispensers may be field retrofit with the Healy VP1000 ISD Enabled by ordering Gilbarco Kit M07801S001 (contains all required parts and instructions).

**Figure 1**



The ball valve and test port required for Healy startup testing and troubleshooting have been moved to locations C and D as shown below in Figure 2.

**Figure 2**



## 2. TESTING, TROUBLESHOOTING, SERVICING AND OTHER QUESTIONS

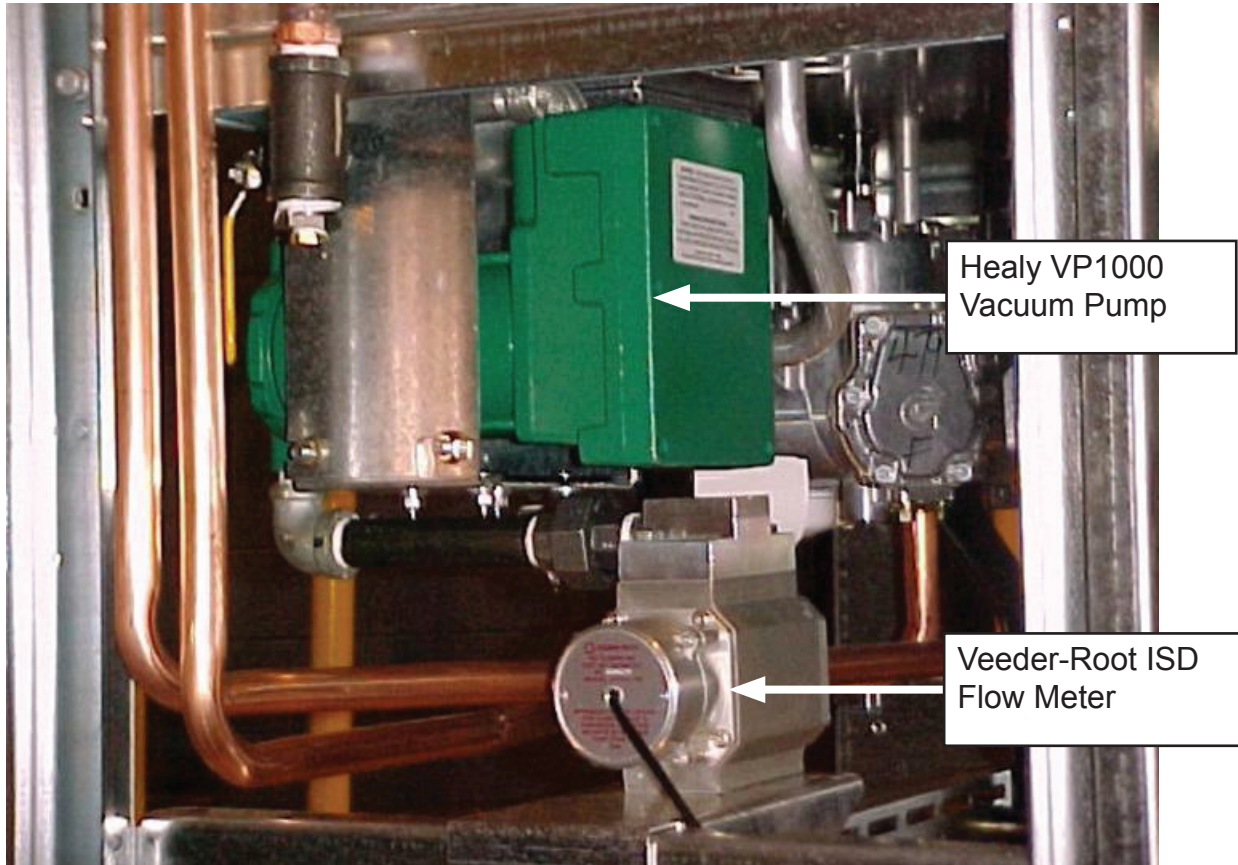
Please refer to Section 13 “TESTING THE SYSTEM” and the “START-UP / NEW INSTALLATION / WARRANTY / ANNUAL TESTING FORM” of the Encore series dispenser retrofit for Healy Systems manual for the detailed instructions on testing the VP1000 vacuum pump and dispenser piping. The manual also includes troubleshooting information in Section 14 if a problem is discovered during testing.



### 3. LOCATION OF VEEDER-ROOT ISD FLOW METER WITH RAISED VP1000

Figure 3 shows the location of the Veeder-Root ISD flow meter when used with the raised Healy VP1000 vacuum pump on a Gilbarco Encore series ISD enabled dispenser. Please refer to the ISD sections of the IOM for information on the proper installation, start-up and operation of the ISD flow meter.

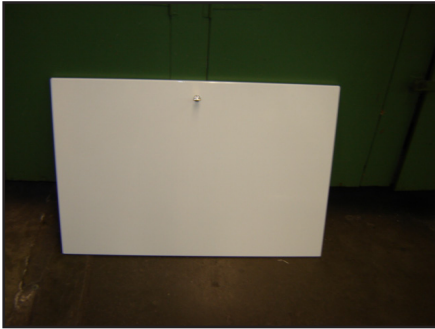
**Figure 3**





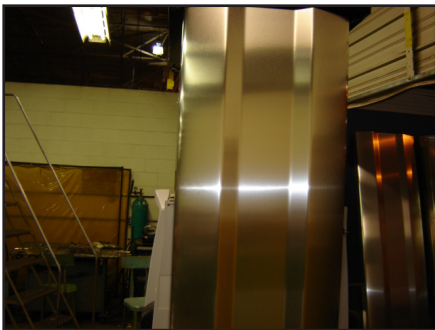
#### 4. HEALY / ISD FLOW METER INSTALLATION PROCESS STEPS FOR KIT M07801S001

- a. Power unit down
- b. Remove lower doors. See Picture 001.



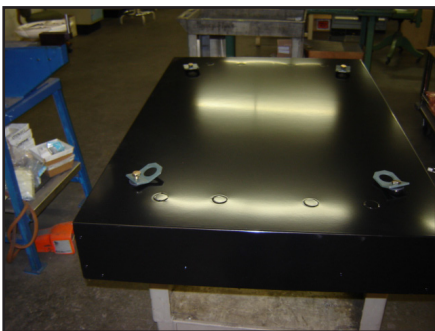
Picture 001

- c. Remove outer column sheathing from both sides of the unit by removing 4 screws holding sheathing to frame. See Picture 002.



Picture 002

- d. Remove upper housing top cover & lift brackets. See Picture 003.

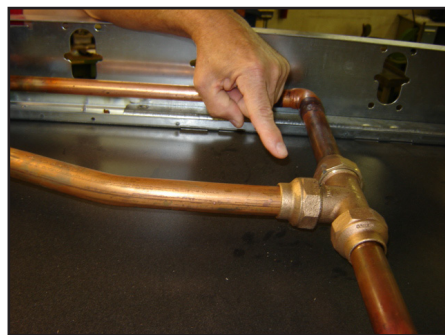


Picture 003

- e. Remove balanced vapor down spout tube by removing u-bolt from bottom of tube on the inlet support rail. Unscrew the nut from the T-fitting in the top of the upper housing. Rotate the T-fitting 180 degrees. See Pictures 004, 005 and 006.



Picture 004



Picture 005



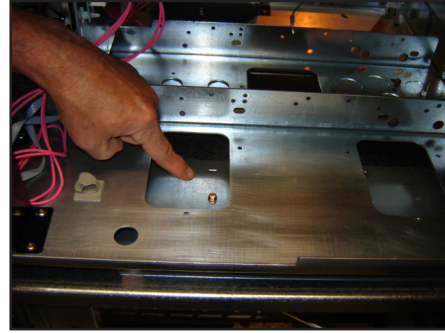
Picture 006

f. Install the new down spout tube to the opposite side of the unit from the previous tube. See Picture 007.



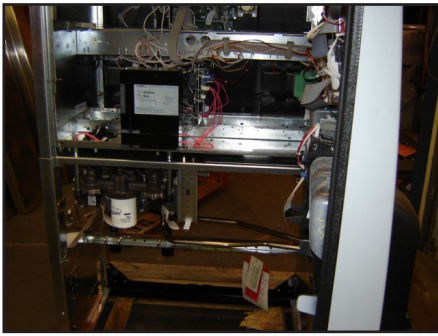
Picture 007

i. Remove the manifold blanking plate from the lower air gap plate by removing (2) screws. See Picture 011.



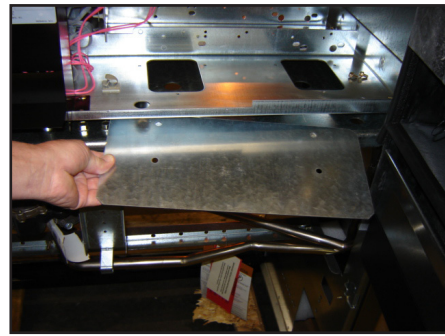
Picture 011

g. Open the Bezel door on "B" side of the unit. See Picture 008.



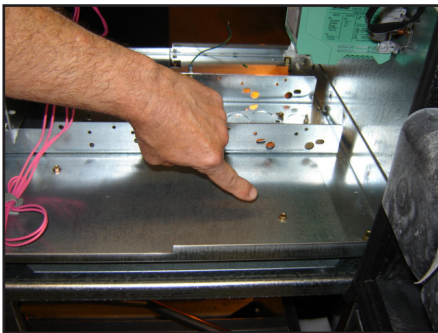
Picture 008

j. Place the Healy mounting plate in place on top of the lower air gap plate. See Picture 012.



Picture 012

h. Remove the manifold blanking plate from the bottom of the cd module by removing (2) screws. See Picture 009.



Picture 009

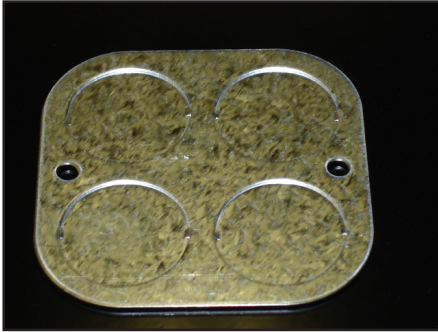
k. Pre-tap the (4) holes in the top of the Healy mounting brackets. Can use the 8 mm self tapping screws that are used to mount the Healy assy. to tap holes. See Picture 013.



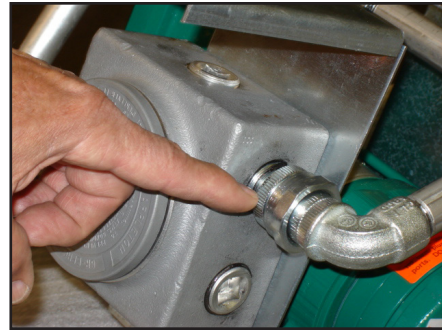
Picture 013



- l. Disconnect any cables coming thru the upper conduit plate located in the cd module the plate. Remove the upper & lower conduit plates by removing (2) screws from each plate. See Picture 014.



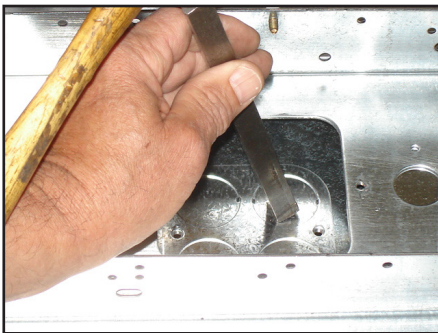
Picture 014



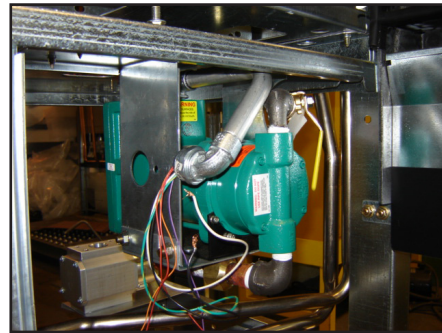
Picture 017

- o. Locate the Healy subassembly below the lower air gap plate and secure it to the plate with (4) screws. You will have to feed the wires from the conduit thru the openings of the lower air gap plate & cd module. See Pictures 018, 019, 020.

- m. Remove the correct knockout from both conduit mounting plates using a hammer & flat head punch. See Picture 17 for correct hole location to knock out.

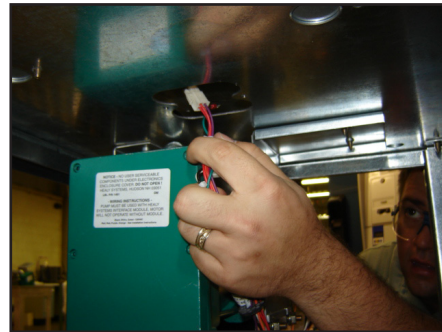


Picture 015

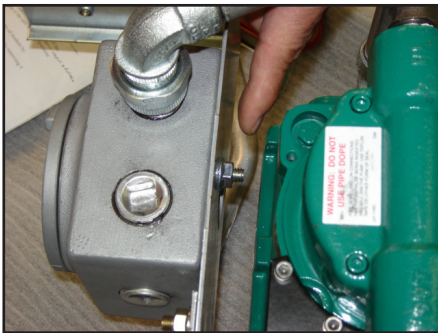


Picture 018

- n. Remove the Auxiliary junction box from the Healy subassembly by removing the nut from the stud on the back of the box. Unhook the conduit & union assembly from the box by loosening the large nut on the union. See Pictures 016, 017.



Picture 019



Picture 016



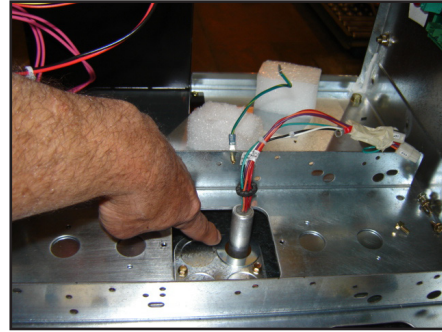
Picture 020

p. Connect the down spout tube to the Healy ball valve assy. by screwing the nut on the tube to the fitting on the ball valve and tightening. See Picture 021.



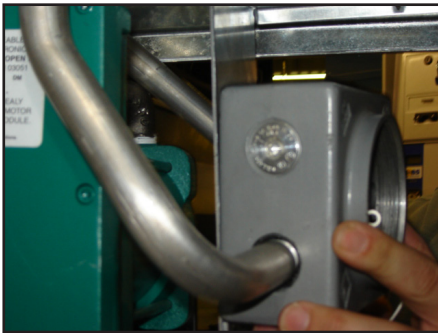
Picture 021

s. Install the conduit mounting plate to the lower air gap plate & install a conduit washer over the conduit coming thru the lower air gap plate from the Healy subassembly. Secure plate with 2 screws. See Picture 024.



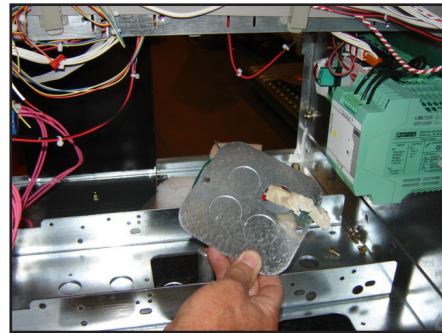
Picture 024

q. Reinstall the auxiliary junction box to the Healy sub assembly. Secure the box to the mounting bracket by installing a nut to the stud coming out of the back of the box. See Picture 022.



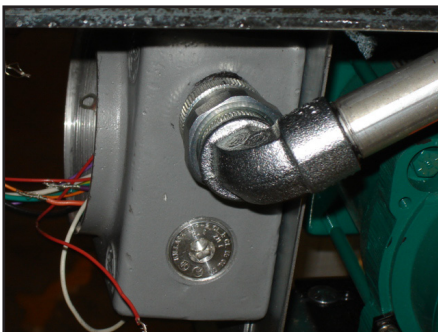
Picture 022

t. Reinstall the upper conduit knockout plate to the cd module using (2) screws. See Picture 025.



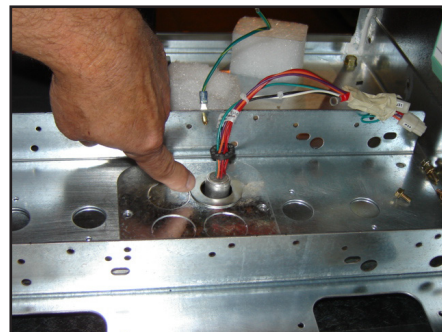
Picture 025

r. Feed the wires from the conduit & union assembly thru the opening in the box and reinstall the union to the box. See Picture 023.



Picture 023

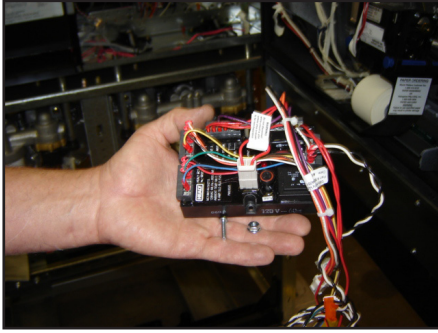
u. Install a washer over the conduit and reconnect any cables that you disconnected. See Picture 026.



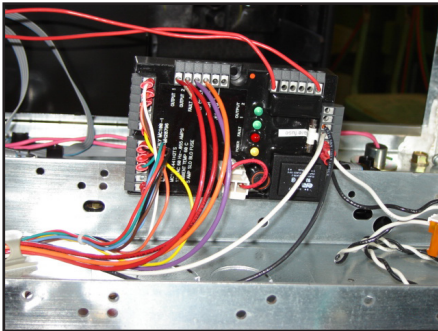
Picture 026



- v. Install a Healy electronic module to the channel in the cd module and secure with a nut and screw. See Pictures 027, 028.

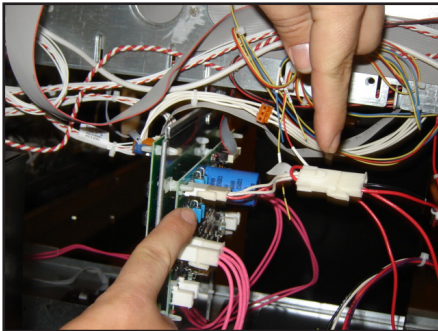


Picture 027

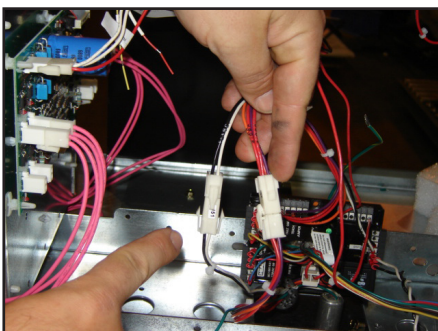


Picture 028

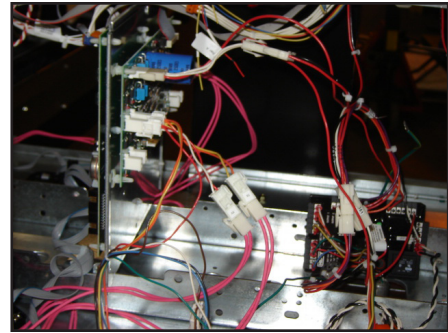
- w. Install cabling to base electronics. See supplied documentation & Pictures 029, 030, 031.



Picture 029



Picture 030



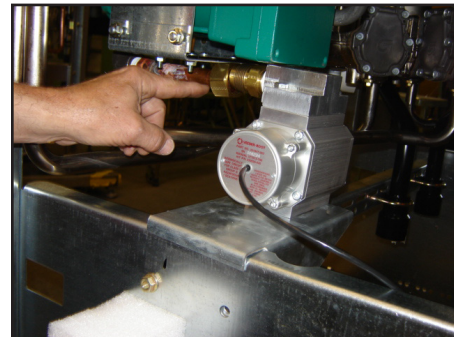
Picture 031

- x. Place the ISD/Flow meter assembly over the top inlet support and the lip of the side column of the lower frame assembly. Secure with (1) 8mm screw. See Picture 032.



Picture 032

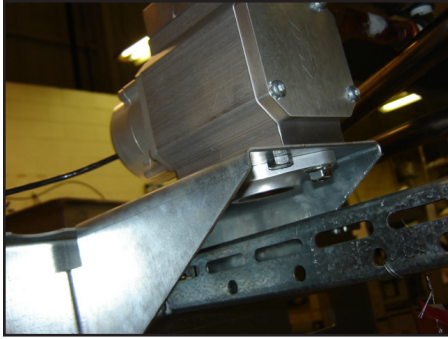
- y. Slide the assembly into place and connect the flare fitting to the tubing nut coming from the Healy pump assy. Tighten the nut. See Picture 033.



Picture 033

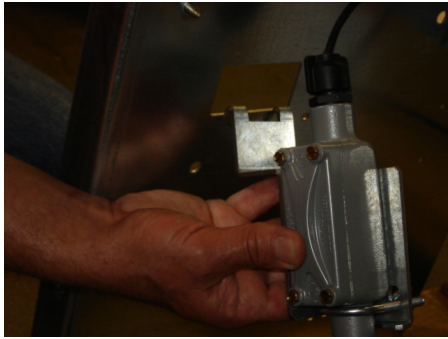


z. Connect the field connection piping to the bottom of the ISD assembly. See Picture 041 for adaptor to connect piping to.



Picture 034

aa. Install the ISD pulser junction box assembly to the frame & secure with one screw. See Pictures 035, 036.



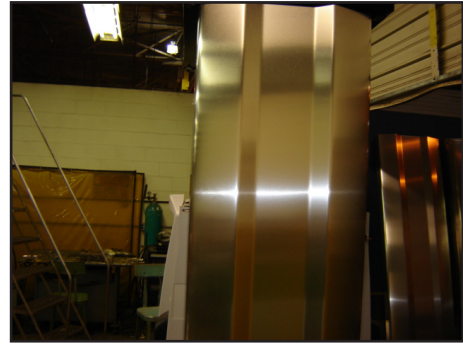
Picture 035



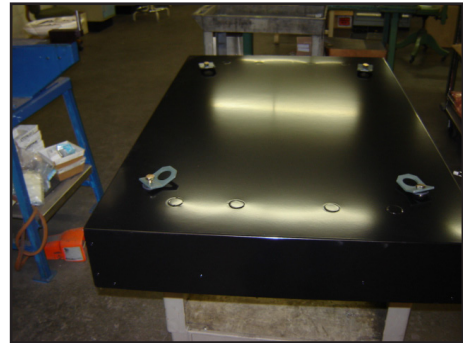
Picture 036

ab. Perform any required field wiring & run test if needed.

ac. Reinstall top cover & sheathing to unit. See Pictures 037, 038.

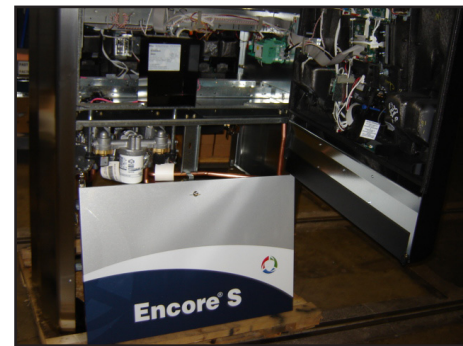


Picture 037



Picture 038

ad. Reinstall lower doors to unit & Close bezel door. See Picture 039.



Picture 039

START-UP/NEW INSTALLATION/ WARRANTY/ ANNUAL TESTING FORM (Rev. 10/07)  
HEALY VP1000 VACUUM PUMP

Date \_\_\_\_\_

**BOTH SIDES OF THIS TEST FORM MUST BE COMPLETED FOR NEW INSTALLATIONS**

- **Start-up / New installations** – complete **SIDE A** and sections 3, 4, 5 and 6 of **SIDE B**. Submit forms to Healy Systems.
- **Warranty Service or Annual Testing** – complete contact information, dispenser make, vacuum pump serial # and the tests in sections 1 and 2 on **SIDE A** and conduct the appropriate tests specified on **SIDE B**. Submit Forms to Healy Systems.

SERVICE COMPANY NAME	TELEPHONE	
SERVICE TECHNICIAN	HEALY TECH CERT #	
STATION ADDRESS	CITY	STATE
DISPENSER MAKE	VACUUM PUMP SERIAL #	

**SIDE A**

DISPENSER EQUIPMENT CHECKLIST - Parts A-1 and A-2	YES	NO*
<b>A-1</b> Is all the installed dispenser hanging hardware listed in Exhibit 1 of Executive Order VR-201 or VR-202?	<input type="checkbox"/>	<input type="checkbox"/>
<b>A-2</b> Proper installation of the VP1000 requires the test port and ball valve on the inlet side of the vacuum pump. Are the test port and ball valve installed correctly?	<input type="checkbox"/>	<input type="checkbox"/>
<b>*If the answer to either A-1 or A-2 is NO, the Healy Warranty is Void.</b>		

**A-3**

- THE FOLLOWING TEST WILL PERFORM A POSITIVE PRESSURE LEAK CHECK OF THE VACUUM PUMP, DISPENSER VAPOR PIPING, HANGING HARDWARE AND ALL NOZZLES ON BOTH SIDES OF THE DISPENSER.
- THE VP1000 OUTLET IS NOT CONNECTED TO UNDERGROUND PIPING DURING THIS TEST.

**CAUTION: REGULATE GASEOUS NITROGEN TO 2.5 PSI (~70" WC) MAXIMUM BEFORE TESTING**

1. Install a 0-100 inch water column (" wc) mechanical gauge at the VP1000 test port.
2. Use the water column gage positive (high) pressure port.
3. Gaseous nitrogen gas can now be connected to the outlet (exhaust) port of the VP1000.
4. Test pressure **cannot** exceed 70" wc.
5. **Slowly** introduce the gaseous nitrogen to a pressure between 60 – 70" wc.
6. After reaching the pressure range, close the valve supplying the gaseous nitrogen.
7. Record the initial pressure reading on the gauge - observe and record the final pressure reading after 60 seconds.
8. Leaks must be repaired when the pressure falls more than 4" wc in 60 seconds.
9. Retest until all leaks have been repaired.
10. Record test results in Section A-4.

<b>A-4</b> <b>PRESSURE TEST</b> 2.5 PSI (~70"wc) Maximum	Initial Pressure test reading ("wc)	Pressure test reading after 60 seconds ("wc)
--	-------------------------------------	--

**BOTH SIDES OF THIS TEST FORM MUST BE COMPLETED FOR NEW INSTALLATIONS**

- **Start-up / New installations – complete SIDE A and sections 3, 4, 5 and 6 of SIDE B. Submit forms to Healy Systems.**
- **Warranty Service or Annual Testing – complete contact information, dispenser make, vacuum pump serial # and the tests in sections 1 and 2 on SIDE A and conduct the appropriate tests specified on SIDE B. Submit Forms to Healy Systems.**

<b>SIDE B</b>			
<i>Warranty Service</i> Complete Troubleshooting Sections <b>B-1 and B-2</b>		<i>Start-up/ New Installations/ Annual Testing</i> Complete Sections <b>B-3 through B-6</b>	
<b>B-1</b>	<p style="text-align: center;"><b>Control Module Fault Light</b> (Circle one)                      <b>Flashing (LED)</b>                      <b>Steady (LED)</b></p> <p>1. All fault conditions require removal and cleaning or replacement of the rotor and vanes located inside the vacuum pumps round front cover assembly. Use the <b>VP1000 ROTOR &amp; VANE SERVICE AND REPLACEMENT GUIDE</b> in the applicable dispenser retrofit manual of the ARB Approved Installation, Operation and Maintenance Manual for Executive Orders VR-201-O and VR-202-O.</p> <p>2. Clean all surfaces including vanes, rotor, rotor housing and cover assembly.</p> <p>3. Manually spin and inspect the motor shaft for bearing wear before re-installing the rotor kit.</p> <p>4. Replace motor when bearings or shaft are damaged or worn.</p> <p>5. Check O-ring seal before replacing rotor cover assembly.</p>		
<b>B-2</b>	<p>Re-Assemble / Reset Vacuum Pump and Module. (Power must be removed from both the vacuum pump and the <b>module for 20 seconds to reset the system</b>) using the power reset switch on the MC100 module.</p>		
<b>B-3</b>	<p style="writing-mode: vertical-rl; transform: rotate(180deg);">Dispenser Vapor Line Integrity Test</p> <p>1. Install 0-100 inch water column (“ wc) vacuum mechanical gauge at the VP1000 test port.</p> <p>2. Authorize the dispenser for fueling. The VP1000 will begin to run.</p> <p>3. Close the ball valve at the pump inlet.</p> <p>4. Record the initial vacuum reading on the gauge – observe and record the final vacuum reading after 60 seconds.</p> <p>5. Open the ball valve at the pump inlet.</p> <p>6. Leaks must be repaired when the vacuum reading falls more than 4” wc in 60 seconds.</p> <p>7. Retest until all leaks have been repaired.</p> <p>8. Record data in Section B-4.</p> <p><b>Note: If the initial vacuum reading is less than 60” wc, it could indicate a problem with the VP1000. Remove the dispenser from service. Use the troubleshooting section of the manual to investigate problem or contact the FFS Technical Help Desk at 800-984-6266 for assistance.</b></p>		
<b>B-4</b>	VACUUM TEST Using VP1000 as vacuum source	Initial Vacuum test reading (“ wc)	Vacuum test reading after 60 sec. (“ wc)
<b>B-5</b>	<p style="writing-mode: vertical-rl; transform: rotate(180deg);">Dispenser Vacuum Test</p> <p>With one side of the dispenser authorized (VP1000 running) and the ball valve at the pump inlet open, dispense in handheld position a minimum of 0.5 gallons of fuel into a vehicle or test tank. Record the vacuum level while dispensing. Repeat test for the other side of the dispenser.</p> <p>1. Side “A” Dispensing Vacuum _____” wc</p> <p>2. Side “B” Dispensing Vacuum _____” wc</p> <p><b>Note: If the dispensing vacuum is less than 60” wc, remove the dispenser from service. See the troubleshooting section of the manual or contact FFS Technical Help Desk at 800-984-6266 for assistance.</b></p>		
<b>B-6</b>	<p style="writing-mode: vertical-rl; transform: rotate(180deg);">Audible Increase Test</p> <p>Test the VP1000 Vacuum Pump for normal operation. Use the 6 step procedure titled, “Testing the VP1000 Vacuum Pump for normal operation using the following test procedure:” in Section 1.1 (Weekly Inspection and Testing) of the Healy Systems Scheduled Maintenance document in the ARB Approved Installation, Operation and Maintenance Manual for the Healy Phase II EVR System not Including ISD. This is to verify that the pump recognizes when both sides of the dispenser are activated for fueling.</p> <p>Does the VP1000 Vacuum Pump change speeds (audible increase) when both sides are activated for fueling?</p> <p style="text-align: center;">Yes No</p> <p>If the answer is no, <b>use the troubleshooting section of the manual to investigate problem or contact the FFS Technical Help Desk at 800-984-6266 for assistance.</b></p>		
Repairs - Comments		To Obtain Returned Materials Authorization number (RMA#) Call 800-984-6266 Forms can be faxed to Franklin Fueling Systems Customer Service at 800-225-9787	

Franklin Fueling Systems  
3760 Marsh Road  
Madison, Wisconsin 53718 USA  
ARB Approved Installation, Operation and Maintenance Manual

Website: <http://www.franklinfueling.com>  
Email: [sales@franklinfueling.com](mailto:sales@franklinfueling.com)  
Telephone: 800-225-9787  
Fax: 608-838-6433

