

# VST Installation Procedure for Phase II Coaxial EVR Balance Fuel Hoses

Part Number Series: VSTA-EVR, VDV-EVR, VSTAP-EVR and VDVP-EVR



**Vapor Systems Technologies, Inc.**

650 Pleasant Valley Drive  
Springboro, Ohio 45066 (USA)

Toll Free: 1-888-878-4673

Phone: 937-704-9333

Fax: 937-704-9443

www.vsthose.com

## GENERAL INFORMATION

If hanging hardware components are involved in a drive-off or incur other customer abuse, each individual component must be functionally tested prior to customer dispensing activities.

**Figure 1.**

EVR Balance Hanging Hardware Assembly

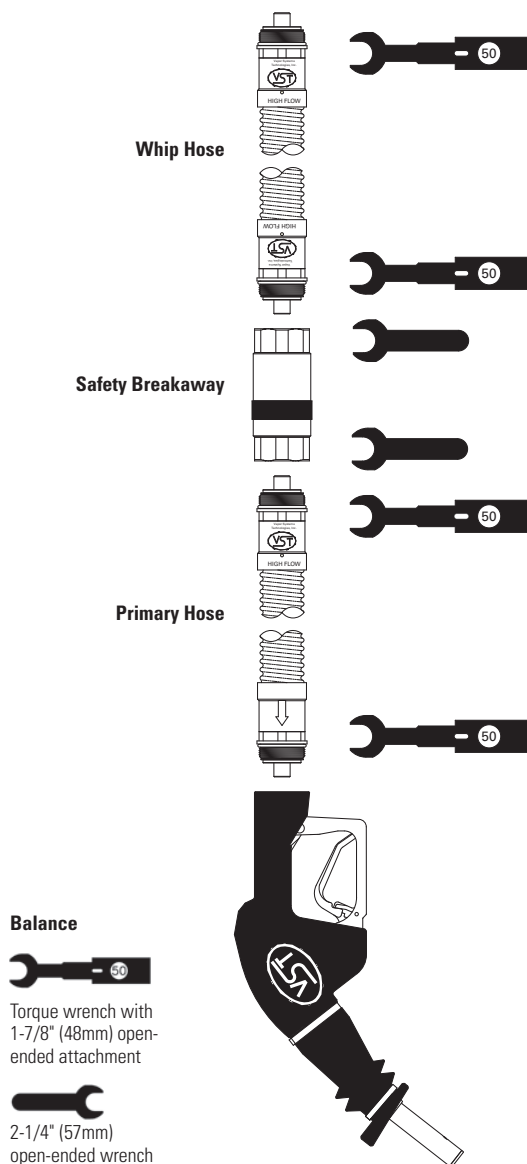

## INSTALLATION PREPARATION

This procedure must be followed to insure leak-proof installation and operation of these hose products.

1. Turn off and tag the power to the dispenser. Dispenser must be de-energized prior to service to avoid personal injury.
2. Barricade work area to block vehicle access to the dispenser.
3. Close the dispenser shear valve prior to removing hanging hardware (hoses, safety breakaways, and nozzles).
4. Drain liquid product from the hanging hardware set into an approved container prior to replacing any hanging hardware components.
5. Remove hanging hardware from the dispenser prior to making replacement component assembly connections. VST recommends connecting the whip hose to the dispenser as the last connection during the hanging hardware assembly.

## INSTALLATION and Function Tests

1. The maximum length of the hose assembly shall not exceed fifteen (15) feet. Lengths greater than fifteen (15) feet are permitted if acceptable to authorities having jurisdiction.
2. Initial inspection:
  - a. Carefully unpack hose from shipping carton.
  - b. Inspect All O-Rings on each end of the hose to determine that they are present and undamaged.
  - c. Inspect hose exterior for any damage.
  - d. Inspect coupling threads for any damage.
3. Lightly lubricate ALL O-Rings on mating connections with petroleum jelly or other suitable lubricant. DO NOT USE pipe dope or thread sealant.
4. Insert the hose coupling into the mating connection and hand tighten.
 

NOTE Flow direction arrows on whip and primary hoses, where applicable, are indicated on hose coupling cuffs.
5. Tighten all the hose-joint connections to 50 foot-pounds of torque. DO NOT OVER TIGHTEN. Use a torque wrench with an open-end attachment to fit the hose couplings and an open-end wrench to properly tighten coupling connections.
 

DO NOT USE channel-locks or pliers to tighten hose joints. Proper ft./lb. torque may not be achieved with these tools.
6. Purge air from the system by pumping one-tenth (1/10) to two-tenths (2/10) of a gallon of fuel into an approved container.

Inspect each hose-joint connection for liquid leaks and meter creep. Make proper adjustments at the hose connection if necessary.

7. Check the nozzle shut-off action by dispensing fuel into an approved container at least three times to assure the proper automatic operation of the interlock rod. The fuel flow-rate must be greater than 3 gpm for the automatic shut-off mechanism to operate.

To test, operate the nozzle and submerge the spout tip in fuel until the fuel level covers the vent hole. The main valve of the nozzle automatically shuts off when the liquid covers the vent hole at the end of the spout. The nozzle is not designed to operate on gravity flow. The hold-open latch will disengage automatically when liquid covers the vent hole in the spout. Verify that the fuel flow stops when the nozzle collection sleeve is decompressed (e.g. interlock rod is disengaged). To test that the fuel flow stops, dispense some fuel into an approved container. Slowly remove the nozzle from the container while dispensing fuel. Fuel flow should stop when the nozzle collection sleeve is fully decompressed.

8. Measure the resistance between the dispenser outlet casting and the tip of the nozzle spout. Use an electronic multimeter set on the high range of the ohmmeter function. Resistance should not indicate more than 70,000 ohms per foot of hose. Example: The measured resistance for a 12-foot hose must not exceed 840,000 ohms (840 kilohms)

### Procedure For Positioning the Liquid Removal Device

This procedure must be followed to insure proper positioning for the liquid-removal device in Part Number Series: VDV-EVR and VDVP-EVR (See Figure 2).

1. After installing the VST hanging hardware, hold the nozzle straight out from the dispenser so that the compressed bellows is 48 inches away from the front face of the dispenser (simulate when the bellows is compressed in the filler neck of a vehicle) and the spout tip of the nozzle is 30 inches above the pavement. The nozzle spout is to be at a 30-degree angle above the horizontal plane.
2. When the hose and nozzle are held in position as shown in Figure 2, the factory installed liquid-removal device indicator-mark (striped line) on the vapor hose must be located:
  - In the bottom of the loop section within the tolerance range
  - The allowable tolerance range is 3 inches left or right of the 6:00 o'clock position (lowest point of the loop) as measured along the center line of the hose

If the liquid-removal device indicator-mark is not located within the tolerance range, the installer must choose one of the following options:

- Adjust the hose retractor (if installed)
- Use a different length whip hose
- Use a different length primary hose

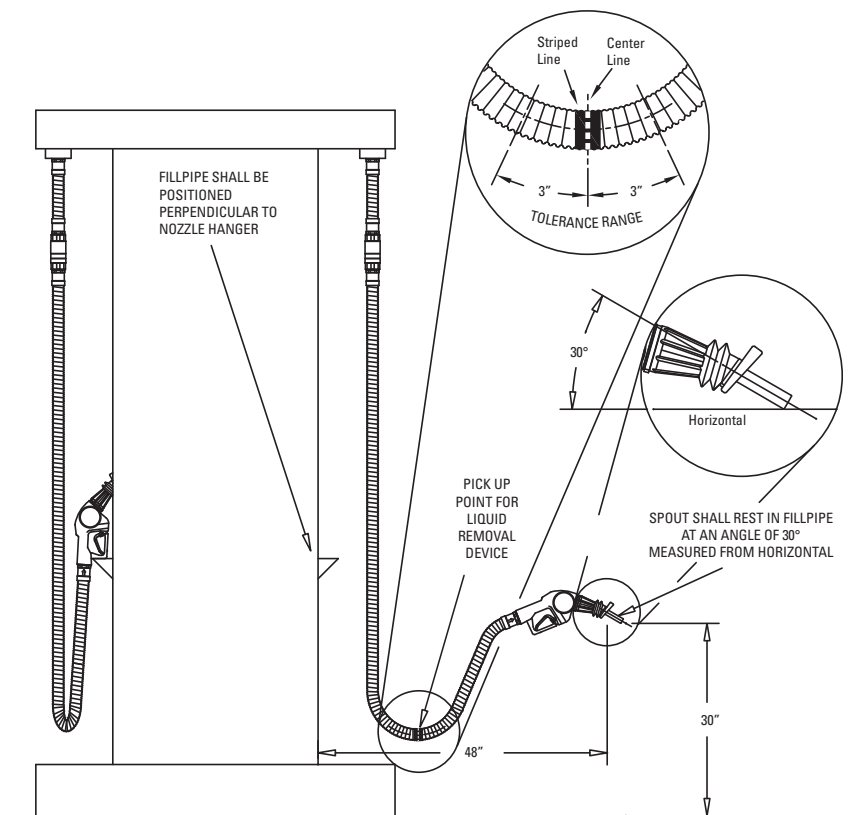

**Figure 2.** Procedure For Positioning the Liquid Removal Device

### IMPORTANT

It is the installing technician's responsibility to insure that the properly sized and marked hanging hardware is installed at the dispenser. Failure to properly install and locate the liquid removal device may reduce the effectiveness of the product in application resulting in outer hose liquid blockage and failure of the liquid removal test procedure.

### MAINTENANCE

Inspect hoses regularly for damage, loose connections, leaks, kinks, blisters, bulges, flattened areas, soft spots, or any cuts/gouges deep enough to expose the reinforcement beneath the hose cover. Replace as necessary. Subject to customer abuse, hoses should be replaced when damaged.

The hose is designed and constructed to give lasting service if properly handled and maintained. If for any reason it should need attention, contact your VST distributor for proper disposition.

### NOTE

Due to abuse, misuse, changing gasoline formulas, variation in maintenance practices, environmental conditions, and/or conditions beyond the manufacturer's control, dispensing equipment may need replacement before five (5) years. Inspections and proper maintenance procedures should be followed by the station manager to determine if replacement is required before five (5) years.

### WARNING

Unauthorized rebuilding or modifying of hoses voids **ALL** approvals and warranties. VST products must be used in compliance with applicable federal, state and local laws and regulations.

# CUSTOMER COPY

**To be left at gasoline dispensing facility (GDF)  
at time of installation**

Manufacturing Date:  
**(SEE BOX LABEL)**

Serial Number: (Fill in at time of installation)

## VST Warranty Statement

This limited warranty is given by Vapor Systems Technologies, Inc. (hereinafter VST) to the initial purchaser, and any subsequent purchasers of new equipment, within the warranty period of products manufactured by VST. VST products:

- Are factory tested and meet all applicable performance standards and specifications.
- Should be used in compliance with all applicable federal, state, and local laws and regulations to which they were certified.
- Are warranted to be free from defect in material and workmanship with ongoing compliance to all applicable performance standards and specifications under normal use, service, proper installation, inspections, and maintenance practices per manufacturer specifications.

VST warrants the materials and workmanship to be free from defects in accordance with the following provisions:

1. This warranty does not apply to any products that have:
  - Been subject to misuse, abuse, tampering, negligence, accident, or drive off.
  - Been misapplied, improperly installed, or not installed per VST’s instructions and specifications.
  - Been modified, altered, rebuilt or repaired by unauthorized persons or outside the criteria of VST specifications.
  - Been improperly maintained and/or improperly inspected in accordance with the system’s or product’s periodic maintenance schedule, and any inspection and/or maintenance requirements imposed by the State or any government agency.
  - Been exposed to contact with fuels containing greater than 5% methanol, 10% ethanol, or 15% MTBE by volume or any exposure to M85/E85 fuel, unless the product is rated for that type of fuel.
  - Been subject to damage resulting from acts of God.
2. This warranty does not cover and VST is not responsible or liable for:
  - Incidental, consequential and/or indirect damages or loss including, but not limited to, personal injury, death, property damage, environmental damage, cost of labor, clean-up, downtime, installation and removal, product damage, and loss of product, revenue or profits.
  - Any claims or lawsuits against the purchaser and/or distributor.
  - Labor or materials necessary to disconnect or connect the warranted product for return to VST.

VST products used on systems that have not been listed by a nationally-recognized testing laboratory (NRTL) or use that falls outside intended field of use voids all warranties.

The duration of this warranty is TWELVE (12) MONTHS from the time of installation provided timely valid proof of installation is submitted to VST. Valid proof of installation options include, but are not limited to:

- VST Product Warranty Registration Card is properly completed and returned to VST at time of installation and within (6) SIX MONTHS from the date of manufacture.

OR

- In lieu of a legitimate, completed and returned VST Product Warranty Registration Card within the first (6) SIX MONTHS from the date of manufacture, VST requires the following:
  1. A completed gasoline dispensing facility (GDF) monthly maintenance log from the month in which the VST equipment was installed and documented, **AND**
  2. One of the following documents that may be used as a reference installation date:
    - A valid distributor invoice
    - A valid contractor invoice

**The above options must be clearly marked with:**

- All VST product serial numbers
- Product sale date and/or installation date
- Purchaser name, address, and phone number

If valid proof of installation is not received by VST, as noted above, the warranty period is TWELVE (12) MONTHS from the VST date of manufacture.

In the event of a warranty claim:

- The purchaser/distributor must obtain a copy of a Return Goods Authorization (RGA) from VST prior to returning product so as to ensure proper processing. All warranty claim returns must be shipped freight prepaid by the purchaser and/or distributor.
- Warranty status will be determined upon inspection at VST's facility within THIRTY (30) DAYS of receipt by VST of the warranted products. All returned merchandise deemed Not Under Warranty; will be held by VST for SEVEN (7) BUSINESS DAYS prior to disposal. Return of this product to the purchaser/distributor will require purchaser/distributor to issue a call tag within SEVEN (7) BUSINESS DAYS of notification.
- Repair or replacement of the warranted product is the **EXCLUSIVE REMEDY** under the terms of this warranty. No other warranty exists.

VST, as to each defect, shall be relieved of all obligations and liabilities under this Limited Warranty if the products have been operated with any accessory, equipment, or a part not specifically approved by VST and the appropriate governing regulatory agencies.

**THIS LIMITED WARRANTY IS EXCLUSIVE AND IS IN LIEU OF ALL OTHER WARRANTIES. VST MAKES NO OTHER WARRANTIES (WHETHER WRITTEN OR ORAL), EXPRESS OR IMPLIED, INCLUDING BUT NOT LIMITED TO ANY IMPLIED WARRANTY OF MERCHANTABILITY, FITNESS FOR A PARTICULAR PURPOSE, OR OTHERWISE, AND ANY OTHER SUCH WARRANTIES ARE HEREBY DISCLAIMED.**

**VST NEITHER ASSUMES NOR AUTHORIZES ANY OTHER PERSON OR ENTITY TO ASSUME FOR IT OR BIND IT TO ANY OTHER LIABILITY OR OBLIGATION RELATED TO OR IN CONNECTION WITH THIS LIMITED WARRANTY.**

VST reserves the right to make changes at any time to prices and designs, or make additions or improvements with respect to its products, without incurring any obligation to modify or install same on previously manufactured products.

✂ Cut along dotted lines for both the Return Tag and the Warranty Registration Card

Warranty Registration Card:

- Cut Out
- Fill out completely
- Return to VST for Warranty Registration at time of installation

Product Return Tag:

- Cut Out
- Fill out completely when submitting a Warranty Return Claim
- Include completed form in box with Warranty Return Claim product
- Include RGA paperwork



**Hose Return Tag**

No warranty accepted without tag filled out and attached to product.

ASC Company: \_\_\_\_\_

Site Name: \_\_\_\_\_

ASC Tech Name: \_\_\_\_\_

Site Street Address: \_\_\_\_\_

ASC #: \_\_\_\_\_

Site City, State & Zip: \_\_\_\_\_

Service Date: \_\_\_\_ / \_\_\_\_ / \_\_\_\_

Site Phone #: \_\_\_\_ - \_\_\_\_ - \_\_\_\_

Claim Serial #: \_\_\_\_\_

Hose Type (check one):

(product removed from service)  
Replacement Serial #: \_\_\_\_\_

- Balance    Assist    Conventional

**Check reason for return - at least one box below must be checked to be considered for a warranty claim:**

- Connection or thread problem
- Failed A/L test (applies to Assist only)
- Failed liquid removal test (applies to Balance only)
- Failed regulatory test ----->
- leaked at coupling ----->
- leaked through the hose wall ----->
- Meter creep ----->
- Other claim - explain (use space to the right)----->

Specify the test that failed: \_\_\_\_\_

Specify which coupling leaked: \_\_\_\_\_

Please explain any "Other claim" below: \_\_\_\_\_

**This side of tag to be filled in by ASC**



**Vapor Systems Technologies, Inc.**

Phone: (937) 704-9333 • Fax: (937) 704-9443  
www.vsthose.com

**IMPORTANT  
PRODUCT WARRANTY  
REGISTRATION CARD**

(FILL OUT WARRANTY REGISTRATION CARD COMPLETELY)

See VST Warranty Statement for complete Warranty details.

A copy of the VST Warranty Statement is included in every product carton.

PRODUCT STYLE:

- HOSE
- NOZZLE
- PROCESSOR
- SAFETY BREAKAWAY
- OTHER

|                                 |       |
|---------------------------------|-------|
| SERIAL NUMBER:                  | _____ |
| INSTALLATION DATE:              | _____ |
| INSTALLATION SITE NAME:         | _____ |
| INSTALLATION CITY/STATE/ZIP:    | _____ |
| INSTALLATION SITE PHONE NUMBER: | _____ |
| DISTRIBUTOR NAME:               | _____ |

✂ Cut along dotted lines for both the Return Tag and the Warranty Registration Card

Product Return Tag:

- Cut Out
- Fill out completely when submitting a Warranty Return Claim
- Include completed form in box with Warranty Return Claim product
- Include RGA paperwork

Warranty Registration Card:

- Cut Out
- Fill out completely
- Return to VST for Warranty Registration at time of installation

# Hose Return Tag

No warranty accepted without tag filled out and attached to product.

**Distributor Name:** \_\_\_\_\_

**Street Address:** \_\_\_\_\_

**City, State & Zip:** \_\_\_\_\_

**Distributor Phone #:** \_\_\_\_\_

**RG A#:** \_\_\_\_\_

**Distributor should check off "all" of the below items for accurate warranty claim processing:**

- RGA number is obtained and filled in on this side of tag
- "Claim serial number" is validated (refer to other side of tag)
- "Replacement serial number" is filled in (refer to other side of tag)
- Verify the "reason for return" is filled in (refer to other side of tag)

**Return product to:** Vapor Systems Technologies, Inc.      **Phone:** 1-888-VST-HOSE  
 650 Pleasant Valley Drive      1-888-878-4673  
 Springboro, Ohio 45066      **Website:** www.vsthose.com      9533-001 01/21

This side of tag to be filled in by Distributor

**Vapor Systems Technologies, Inc.**  
 650 Pleasant Valley Drive  
 Springboro, Ohio 45066

\_\_\_\_\_

\_\_\_\_\_

\_\_\_\_\_