





Chapter 1: General Contractor Installation

1 Installation Instructions

1.1 Installation Safety for all Contractors

	<ul style="list-style-type: none">• The GREEN MACHINE will be installed near locations where highly flammable and explosive gasoline vapors may be present.
	<ul style="list-style-type: none">• Installation of the GREEN MACHINE must comply with the National Electric Code, federal, state and local codes, as well as other applicable safety codes.• Use extreme caution due to the risk of fire or explosion, which could result in serious injury or even death.
	<ul style="list-style-type: none">• If you are working in an area where vehicle traffic may occur, always block off the work area during installation, testing, and service to protect yourself and others.• Do not use power tools that can generate sparks if there is a risk of flammable or explosive vapors being present.• Read and understand all materials related to installing, testing, and operating the GREEN MACHINE prior to installation.

1.2 Preparing the GREEN MACHINE for Installation

Follow these steps to prepare the GREEN MACHINE for installation:

1. Verify that all the items are in the shipping crate:
 - GREEN MACHINE - VST-GM-CS2-101-2
 - Aluminum Cover
 - VST Control Panel
 - (4) 24" Steel Legs
 - (16) 3/8" bolts / washers / nuts to attach the legs to the GREEN MACHINE base
 - (1) 0.063" dia. Orifice
 - (6) Locks with keys (same)
 - (3) 1" Brass Full Port Ball Valves, Locking
2. Visually inspect all the items for any obvious damage.
3. CAUTION: Uncrate and install the four legs on the GREEN MACHINE prior to transporting to the installation site. Installing the legs on site without proper support may cause damage to the unit.



Scan for Video

1.3 Installing the Legs on the GREEN MACHINE

1. Support the GREEN MACHINE with a forklift or a set of saw horses so the legs can be installed.
2. Install the 4 legs on the GREEN MACHINE. The four 3/8" carriage bolts for each leg MUST BE INSTALLED AND TIGHTENED IN THE SEQUENCE INDICATED ON **Figure 1-1**.
3. All the carriage bolts must be installed so the head of the bolt is flush with the base as shown.

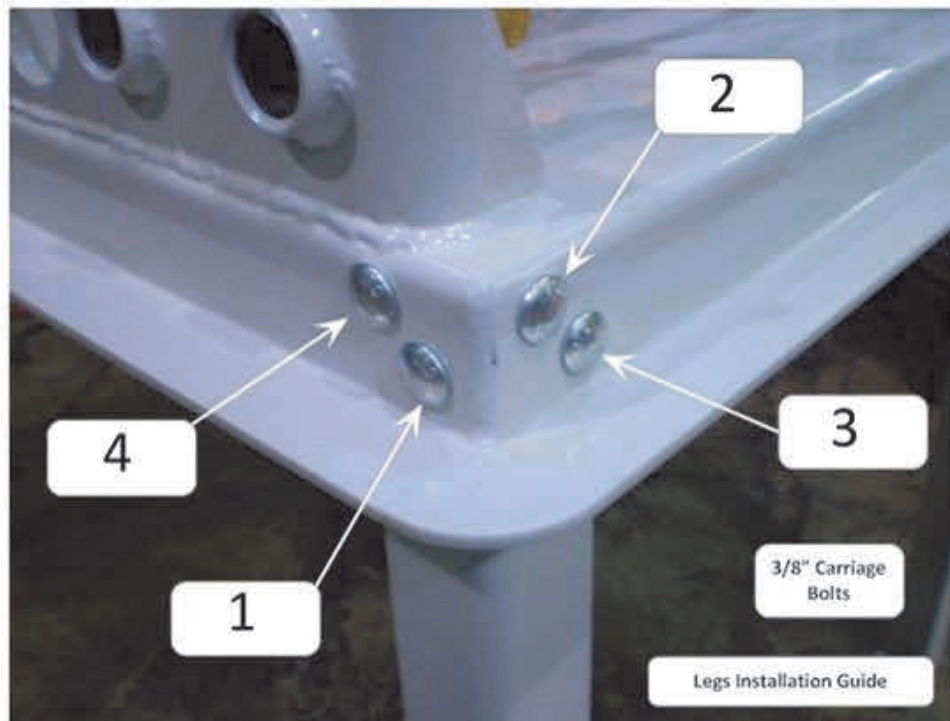

Figure 1-1: Bolting sequence to attach legs to the GREEN MACHINE base



1.4 GREEN MACHINE Dimensions & Weight

Unit	Dimensions	Weight
GREEN MACHINE	L-39" x W-27" x H-49.89" Height includes 24" legs	282 lbs. w/out Cover w/out Control Panel
Aluminum Cover	L-39" x W-27" x H-25" (one-piece unit)	24 lbs.
VST Control Panel	L-14" x W-12" x H-8"	22 lbs.

1.5 Ground Mount Locations

- NOTE: Minimum vapor-piping slope must always be maintained for all GREEN MACHINE mounting options.
 - VST requires a minimum slope of $\frac{1}{4}$ " per foot on all vapor piping away from the GREEN MACHINE to the vent risers.
 - Select a location for the concrete pad as close as possible to the vent risers to minimize piping and pressure drop.
- The GREEN MACHINE must be protected from damage:
 - Install bollards or another suitable method to protect the GREEN MACHINE.
- VST recommends a clear 18" perimeter around the GREEN MACHINE for maintenance and testing.
- The GREEN MACHINE must be located within 100 feet of the vent risers.
- To minimize the installation cost and to maximize operating efficiency, locate the GREEN MACHINE adjacent to the existing vent risers.
- A new air outlet vent riser connected to the GREEN MACHINE must be installed to release air to the atmosphere.
- VST recommends setting the GREEN MACHINE on a concrete pad with the following minimum dimensions: 42" long x 30" wide, 6" thick.
 - Install the concrete pad as outlined in this manual.
- Follow the local jurisdiction's building codes.
- VST does not provide any hardware to install the GREEN MACHINE on the pad.



1.6 Setting the Concrete Pad

- The soil must have the following capabilities:
 - Allowable bearing pressure: 1000 psf
 - Lateral bearing: 150 psf
 - Coefficient of sliding: 0.25
- The GREEN MACHINE must be installed on a concrete pad, on grade, and permanently anchored to the concrete pad.
 - Install the concrete pad level.
 - Use steel re-enforced rebar in the pad for additional strength.
 - The GREEN MACHINE CANNOT be installed directly on or anchored directly to asphalt. It must be installed and anchored directly to a concrete pad.
- The GREEN MACHINE can be installed on an existing concrete pad, provided:
 - The existing concrete is of sufficient strength and thickness to support the GREEN MACHINE.
 - VST recommends a minimum of 6" thick concrete to accommodate 3-1/2" – 4" expansion-type anchor bolts.
 - Cracked concrete without re-bar may NOT be of sufficient strength to properly support the GREEN MACHINE.
 - The GREEN MACHINE is installed level.
 - NOTE: VST CANNOT BE HELD RESPONSIBLE FOR DAMAGE CAUSED BY IMPROPER GREEN MACHINE FOUNDATION SUPPORT.
- VST does not provide any hardware to install the GREEN MACHINE on the pad.
- VST recommends using an 18" minimum clearances around the perimeter of the GREEN MACHINE for maintenance and service.
- Concrete pad minimum dimensions:
 - 42" long x 30" wide
 - 6" thick (minimum)
 - **See Figures 1-2 and 1-3**
- Install expansion-type bolts after completing the concrete pad. The bolts must be:
 - 3/8" diameter
 - Embedded 3-1/2" to 4" into the slab
 - Extend approx. 1-1/2" above the top of the slab



1.7 Installing the GREEN MACHINE on the Concrete Pad

- After the concrete has properly cured, install the expansion anchor bolts according to the manufacturer's recommendations. **See Figures 1-2 and 1-3.**
- For applications that require expansion anchors that are especially suited to seismic and cracked concrete, VST recommends using the HILTI KWIK TZ (KB-TZ) BOLT, KB-TZ 3/8" X 5", (item number 00304583) or approved equal.
- The contractor or design engineer is responsible for sizing the expansion anchors and the concrete pad to meet seismic and cracked concrete specifications required by local, state, and federal jurisdictions.
 - Since seismic regulations may be different by location, VST has not included a specific drawing for this application.
 - For seismic design reference, www.us.hilti.com.
- After the appropriate anchor bolts have been installed, position the GREEN MACHINE onto the anchor bolts in the cement slab.
- Bolt the GREEN MACHINE into place (according to the manufacturer recommended installation guidelines) with 3/8" galvanized lock washers and bolts that are included with the expansion bolt.

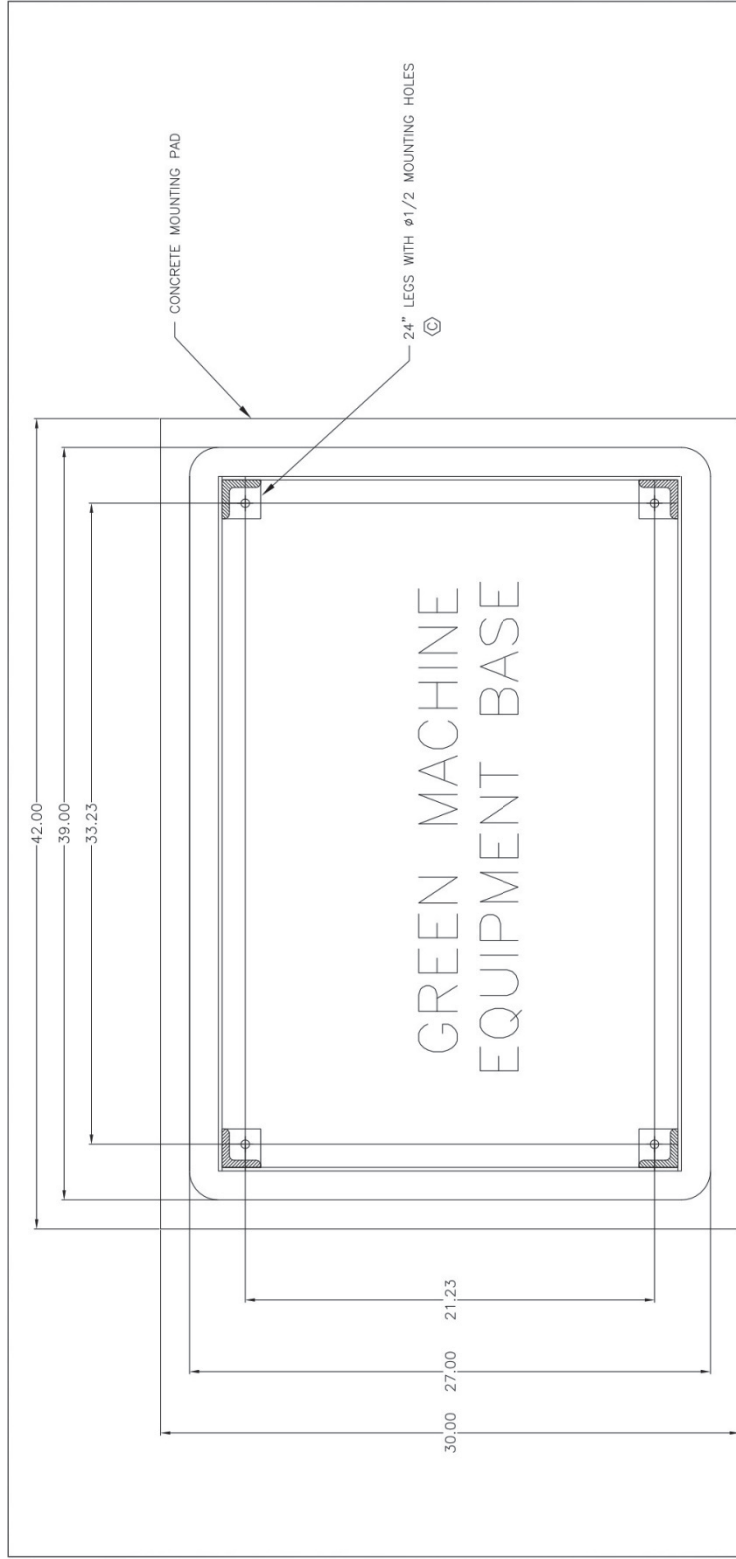

NOTES:

1. MIN. CONCRETE COMP. STRENGTH = 2500 PSI
2. MIN. REINFORCEMENT YIELD STRENGTH = 40000 PSI
3. CONCRETE MUST BE INSTALLED LEVEL

REV	DESCRIPTION	DATE	BY
1772	PER EC	01/26/18	

DATE	DATE	TITLE	DRG NO.	REV
07/18/18	01/26/18	GROUND MOUNTING PAD	6504-001	C
01/26/18	01/26/18	DIMENSIONS, GREEN MACHINE		

THE INFORMATION ON THIS DOCUMENT IS PROPRIETARY.
 IT MAY BE USED ONLY FOR THE PROJECT AND SITE
 IDENTIFIED ON THIS DOCUMENT. ANY REUSE IS PROHIBITED.

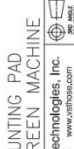

Figure 1-2: Concrete mounting pad dimensions

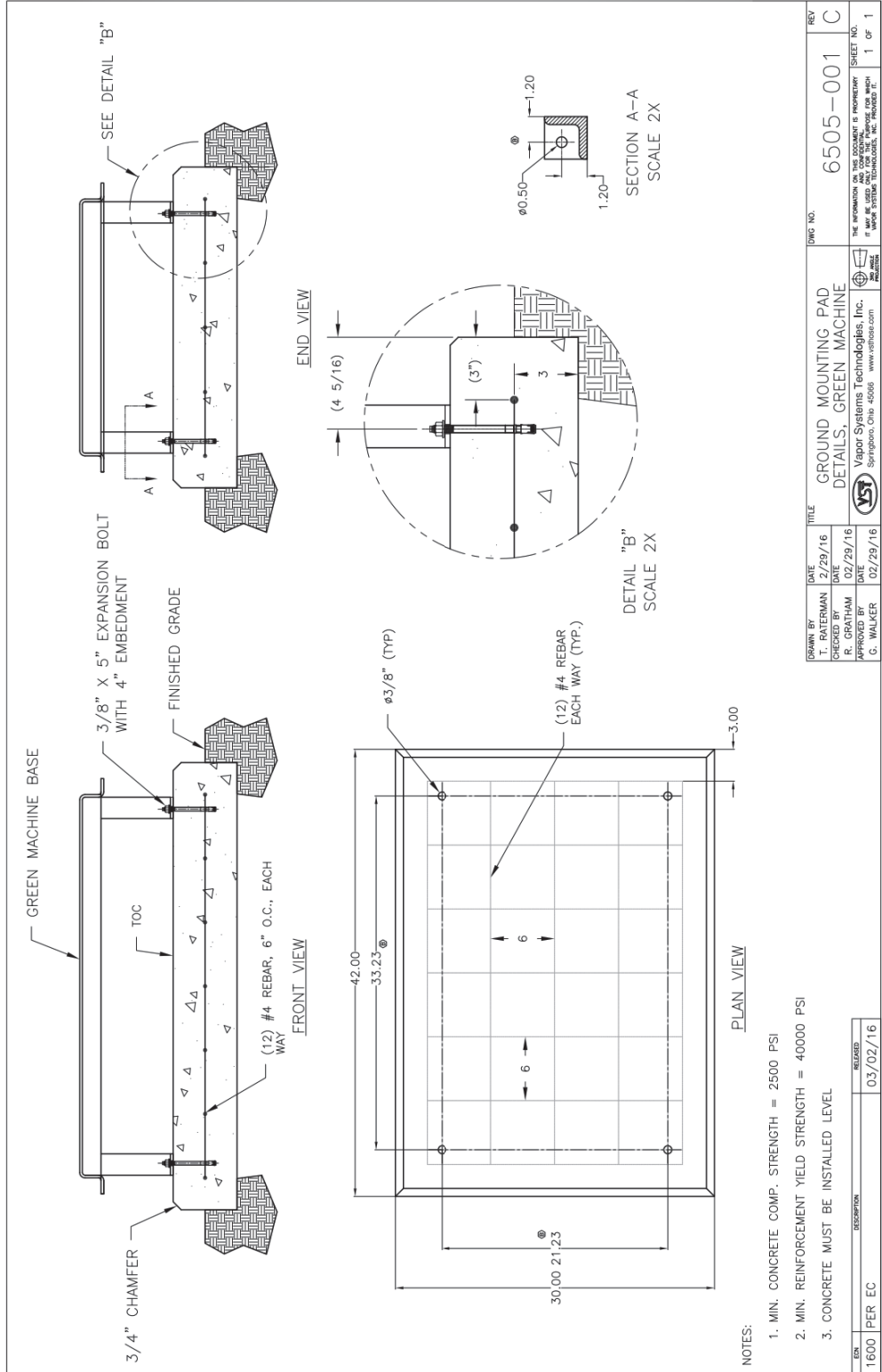

Figure 1-3: GREEN MACHINE Ground Mounting Pad



1.8 Roof-Top Installation

- NOTE: Minimum vapor-piping slope must always be maintained for all GREEN MACHINE mounting options.
 - VST requires a minimum slope of $\frac{1}{4}$ " per foot on all vapor piping away from the GREEN MACHINE to the vent risers.
- The GREEN MACHINE may be installed on a station's roof provided the structure can support the weight of the GREEN MACHINE.
- All safety and code concerns must be taken into consideration prior to a roof-top installation.
- Due to a variety of roof construction designs, VST cannot recommend how the GREEN MACHINE should be mounted on the roof; however, the GREEN MACHINE must be installed at a height allowing the piping inlet and outlets to be above or through the building parapet.
- The GREEN MACHINE has 24" legs that can be bolted on the base, but the legs may be removed and the GREEN MACHINE secured to a steel structure attached to the roof.
- A new air outlet vent riser connected to the GREEN MACHINE must be installed to release air to the atmosphere.
- A Design Engineer is responsible for designing the support structure, support base, all required hardware and bolting connections, and the support structure foundation to meet all regulatory specifications that may be required by local jurisdictions.

1.9 Canopy-Top Installation

- NOTE: Minimum vapor-piping slope must always be maintained for all GREEN MACHINE mounting options.
 - VST requires a minimum slope of $\frac{1}{4}$ " per foot on all vapor piping away from the GREEN MACHINE to the vent risers.
- The GREEN MACHINE may be installed on a station's canopy provided the structure can support the weight of the GREEN MACHINE.
- Due to a variety of canopy construction designs, VST cannot recommend how the GREEN MACHINE should be mounted on the canopy.
- All safety and code concerns should be taken into consideration prior to a canopy-top installation.
- The GREEN MACHINE has 24" legs that can be bolted on the base, but the legs may be removed and the GREEN MACHINE secured to a steel structure attached to the canopy support structure.



Canopy-Top Installation, continued...

- A new air outlet vent riser connected to the GREEN MACHINE must be installed to release air to the atmosphere.
- A Design Engineer is responsible for designing the support structure, support base, all required hardware and bolting connections, and the support structure foundation to meet all regulatory specifications that may be required by local jurisdictions.

1.10 Vent-Stack Mount Installation

- NOTE: Minimum vapor-piping slope must always be maintained for all GREEN MACHINE mounting options.
 - VST requires a minimum slope of $\frac{1}{4}$ " per foot on all vapor piping away from the GREEN MACHINE to the vent risers.
- The GREEN MACHINE may be installed elevated on the existing vent risers provided there is an existing structure that can support the weight of the GREEN MACHINE, or a structure can be installed to support the weight of the GREEN MACHINE.
- Due to a variety of construction designs, VST cannot recommend how the GREEN MACHINE should be installed or mounted on a vent riser support structure; however, the structure that supports the GREEN MACHINE must be designed and installed at a height allowing the piping inlet and outlets to connect to the existing vent risers.
- The GREEN MACHINE has 24" legs that can be bolted on the base, but the legs may be removed for the GREEN MACHINE to be secured to a steel support structure.
- A new air outlet vent riser connected to the GREEN MACHINE must be installed to release air to the atmosphere.
- All safety and code concerns must be taken into consideration prior to vent stack mount installation.
- A Design Engineer is responsible for designing the support structure, support base, all required hardware and bolting connections, and the support structure foundation to meet all regulatory specifications that may be required by local jurisdictions.
- **See Figure 1-4** for illustration.

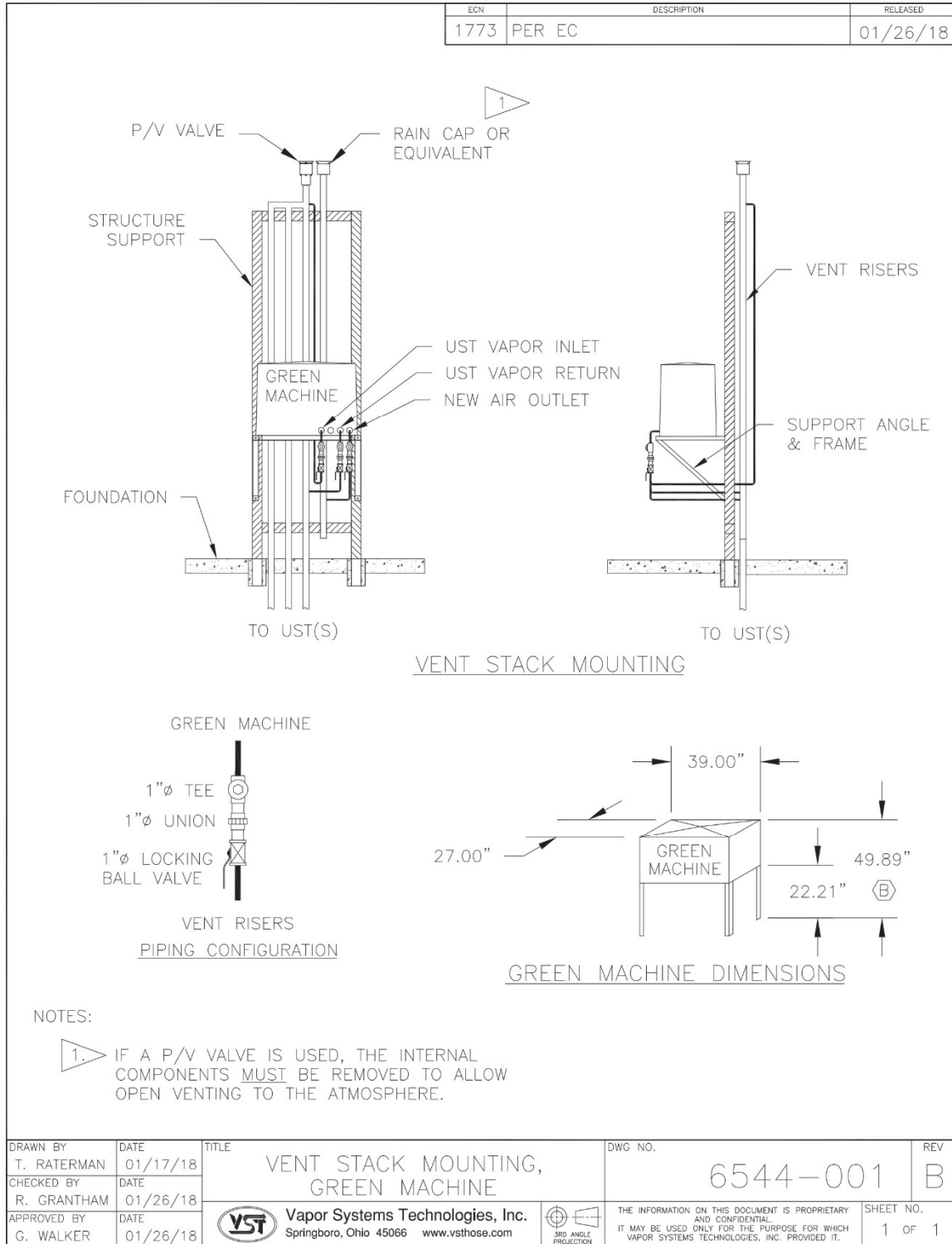

Figure 1-4: Vent Stack Installation



1.11 Pre-Installation Site Survey

- Vapor Systems Technologies, Inc. created a “Pre-Installation Site Survey” as a guide to help installers and troubleshooters in the planning of a GREEN MACHINE installation.
- The “Pre-Installation Site Survey” is to be completely filled out in advance of an installation so that installation problems and delays are reduced or avoided.

1.12 Pre-Installation Site Survey

Your Name:	
Company Name:	
Company Address:	
City, State, Zip	
Country	
Phone:	
E-Mail:	
Projected Processor Installation Date:	

1.13 GDF Contact Information

GDF Name:	
GDF Address:	
GDF City, State, Zip:	
GDF Country:	
GDF Phone:	
GDF Fax:	
GDF #:	
GDF Contact Person:	
GDF Contact Person E-mail:	
NOTES:	



1.14 Snapshot of Site Requirements

Local Air Pollution Control Districts	
<ul style="list-style-type: none">• Gasoline stations must contact the local/national authorities for specific requirements.	
<ul style="list-style-type: none">• Permits may be required to modify a gasoline station.	
Installation Requirements	
<ul style="list-style-type: none">• The GREEN MACHINE must be within 100 feet of the Vent Risers regardless of the installation location.	
<ul style="list-style-type: none">• VST requires a minimum slope of $\frac{1}{4}$" per foot on all vapor-piping away from the GREEN MACHINE to the Vent Risers or to any other UST connection.	
<ul style="list-style-type: none">• A minimum clearance of 18" around the GREEN MACHINE for maintenance and testing is required.	
<ul style="list-style-type: none">• The GREEN MACHINE must be protected from damage: Install bollards or other suitable method to protect the GREEN MACHINE.	
Automatic Tank Gauge, Fuel Management Controls	
<ul style="list-style-type: none">• Must have an appropriate automatic tank gauge fuel measurement control with an Overfill Alarm contact installed.	
<ul style="list-style-type: none">• The GREEN MACHINE Controller will use the Overfill Alarm contacts to shut OFF the GREEN MACHINE so gasoline cannot enter the GREEN MACHINE in case of an overfill. If gasoline enters the GREEN MACHINE because of an overfill, the warranty will be voided.	
VST Control Panel	
<ul style="list-style-type: none">• VST Control Panel completely powers the GREEN MACHINE via one 115 VAC, single-phase, 20-amp breaker.	
<ul style="list-style-type: none">• The VST Control Panel arrives from the factory internally pre-wired and pre-tested.	



Snapshot of Site Requirements, continued...

Vent Risers	
<ul style="list-style-type: none">• UST's must be manifolded either above ground if there are multiple vent risers or at the vapor piping below ground.	
<ul style="list-style-type: none">• Only one existing vent riser connected to the USTs is required for the installation of the GREEN MACHINE.	
<ul style="list-style-type: none">• A new vent riser is required, and is connected to the Air Outlet on the GREEN MACHINE.	
<ul style="list-style-type: none">• VST requires all vapor-piping connecting to the GREEN MACHINE must be sloped away from the GREEN MACHINE a minimum of ¼" per foot slope.	
<ul style="list-style-type: none">• Any type of trap, regardless of the GREEN MACHINE location, is not permitted in any vapor lines connected to the GREEN MACHINE.	
UST Manifolding	
<ul style="list-style-type: none">• All gasoline UST's MUST be manifolded either above or below ground.	
Ground Installation Requirements	
<ul style="list-style-type: none">• The GREEN MACHINE must be protected from damage.	
<ul style="list-style-type: none">• VST recommends a clear 18" perimeter around the GREEN MACHINE for maintenance and testing.	
<ul style="list-style-type: none">• The GREEN MACHINE must be located within 100 feet of the vent risers.	
<ul style="list-style-type: none">• To minimize the installation cost and to maximize operating efficiency, locate the GREEN MACHINE adjacent to the existing vent risers.	
<ul style="list-style-type: none">• A new air outlet vent riser connected to the GREEN MACHINE must be installed to release air to the atmosphere.	
<ul style="list-style-type: none">• VST recommends setting the GREEN MACHINE on a concrete pad with the following minimum dimensions: 42" long x 30" wide, 6" thick.	
<ul style="list-style-type: none">• Follow the local jurisdiction's building codes.	
<ul style="list-style-type: none">• VST does not provide any hardware to install the GREEN MACHINE on the pad.	



Snapshot of Site Requirements, continued...

Roof Top Installation Requirements	
<ul style="list-style-type: none">• The GREEN MACHINE may be installed on a station's roof provided the structure can support the weight of the GREEN MACHINE.	
<ul style="list-style-type: none">• Due to a variety of roof construction designs, VST cannot recommend how the GREEN MACHINE should be mounted on the roof; however, the GREEN MACHINE must be installed at a height allowing the piping inlet and outlets to be above or through the building parapet.	
<ul style="list-style-type: none">• All safety and code concerns must be taken into consideration prior to a roof-top installation.	
<ul style="list-style-type: none">• The GREEN MACHINE has 24" legs that can be bolted on the base, but the legs may be removed and the GREEN MACHINE secured to a steel structure attached to the roof.	
<ul style="list-style-type: none">• A new air outlet vent riser connected to the GREEN MACHINE must be installed to release air to the atmosphere.	
<ul style="list-style-type: none">• A Design Engineer is responsible for designing the support structure, support base, all required hardware and bolting connections, and the support structure foundation to meet all regulatory specifications that may be required by local jurisdictions.	
Canopy Top Installation Requirements	
<ul style="list-style-type: none">• The GREEN MACHINE may be installed on a station's canopy provided the structure can support the weight of the GREEN MACHINE.	
<ul style="list-style-type: none">• Due to a variety of canopy construction designs, VST cannot recommend how the GREEN MACHINE should be mounted on the canopy.	
<ul style="list-style-type: none">• All safety and code concerns must be taken into consideration prior to a canopy top installation.	
<ul style="list-style-type: none">• The GREEN MACHINE has 24" legs that can be bolted on the base, but the legs may be removed and the GREEN MACHINE secured to a steel structure attached to the canopy support structure.	
<ul style="list-style-type: none">• A new air outlet vent riser connected to the GREEN MACHINE must be installed to release air to the atmosphere.	
<ul style="list-style-type: none">• A Design Engineer is responsible for designing the support structure, support base, all required hardware and bolting connections, and the support structure foundation to meet all regulatory specifications that may be required by local jurisdictions.	



Snapshot of Site Requirements, continued...

Vent Stack Installation Requirements	
<ul style="list-style-type: none">• The GREEN MACHINE may be installed elevated on the existing vent risers provided there is an existing structure that can support the weight of the GREEN MACHINE, or a structure can be installed to support the weight of the GREEN MACHINE.	
<ul style="list-style-type: none">• Due to a variety of construction designs, VST cannot recommend how the GREEN MACHINE should be installed or mounted on a vent riser support structure; however, the structure that supports the GREEN MACHINE must be designed and installed at a height allowing the piping inlet and outlets to connect to the existing vent risers.	
<ul style="list-style-type: none">• The GREEN MACHINE has 24" legs that can be bolted on the base, but the legs may be removed for the GREEN MACHINE to be secured to a steel support structure.	
<ul style="list-style-type: none">• A new air outlet vent riser connected to the GREEN MACHINE must be installed to release air to the atmosphere.	
<ul style="list-style-type: none">• All safety and code concerns must be taken into consideration prior to vent stack mount installation.	
<ul style="list-style-type: none">• A Design Engineer is responsible for designing the support structure, support base, all required hardware and bolting connections, and the support structure foundation to meet all regulatory specifications that may be required by local jurisdictions.	

1.15 Other Information to Document

1.15.1 Gasoline Stations

1.	Monthly throughput (gallons)	
2.	Hours open (example: 9am-11pm or 24 hrs.)	
3.	Number of Underground Storage Tanks	
4.	Size of Underground Storage Tanks (gallons)	



1.15.2 Dispensers

1.	Make & Model	
2.	Conventional, Assist, or Balance (OD of Vapor Pipe)	
3.	MPD or Unihose	
4.	Number of dispensers	
5.	Is the current hose a VST hose	<input type="checkbox"/> Yes <input type="checkbox"/> No
6.	Do the current hoses have a retractor	<input type="checkbox"/> Yes <input type="checkbox"/> No
7.	Curb hose length	
8.	Whip hose length	
9.	Hose configuration	<input type="checkbox"/> Standard <input type="checkbox"/> Lazy J <input type="checkbox"/> Curly Q

1.15.3 Vent Risers

1.	Number of vent risers	
2.	Location & size of vent risers (show on sketch)	
3.	Where are the USTs manifolded	<input type="checkbox"/> Above Ground <input type="checkbox"/> Below Ground

1.15.4 VST GREEN MACHINE

1.	What are the possible locations that can be used for the VST GREEN MACHINE	<input type="checkbox"/> Ground <input type="checkbox"/> Roof <input type="checkbox"/> Canopy <input type="checkbox"/> Vent Riser
2.	Will a waiver or variance be needed for a ground-mount location	<input type="checkbox"/> Yes <input type="checkbox"/> No
3.	Does the site have overfill protection?	<input type="checkbox"/> Yes <input type="checkbox"/> No
	Can we connect to the fuel management system signal for the VST GREEN MACHINE	<input type="checkbox"/> Yes <input type="checkbox"/> No



1.15.5 Electrical

1.	Does the GDF have 1-Phase 115V available?	<input type="checkbox"/> Yes	<input type="checkbox"/> No
2.	Are there any existing conduits at or near the proposed VST GREEN MACHINE location (for example: lights, signs, vacuum)?	<input type="checkbox"/> Yes	<input type="checkbox"/> No
3.	Available breaker space for a 115V 1-phase circuit?	<input type="checkbox"/> Yes	<input type="checkbox"/> No
4.	Will a sub-panel need to be installed?	<input type="checkbox"/> Yes	<input type="checkbox"/> No

1.15.6 Additional Documentation

•	Include photos of each of the above items as needed.
•	Draw a sketch of the GDF layout. Include:
a)	The location of the vent risers
b)	Tank pad
c)	Dispensers
d)	Building with the electrical panel location
e)	Property lines
f)	Any existing conduits near the proposed GREEN MACHINE location.

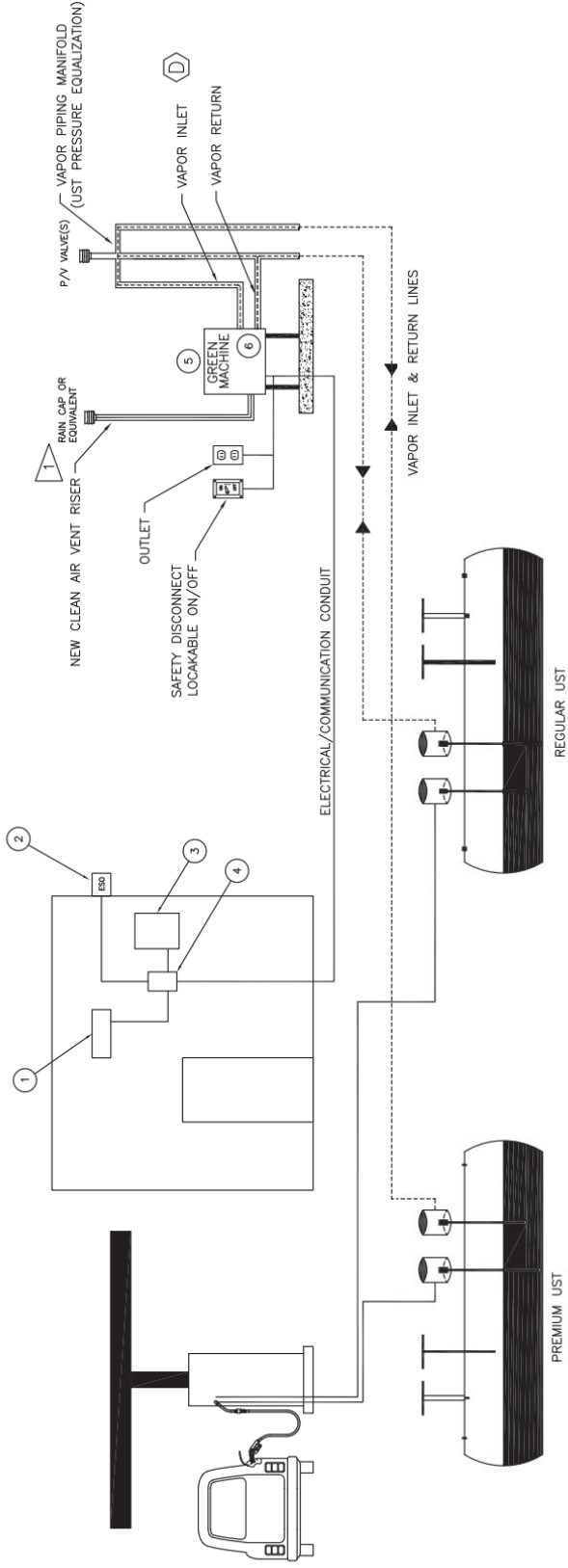

NOTES:
 1 IF A P/V VALVE IS USED, THE INTERNAL COMPONENTS SHOULD BE REMOVED TO ALLOW OPEN VENTING TO THE ATMOSPHERE.

REV	DESCRIPTION	RELEASED	DATE	TITLE	DWG. NO.	REV
1724	ADDED VAPOR INLET/VAPOR RETURN LINES		02/24/17	GDF LOCATION, SITE OVERVIEW, GREEN MACHINE	6524-001	D

ITEM	DESCRIPTION
6	PRESSURE SENSOR
5	GREEN MACHINE ASSEMBLY
4	VST CONTROL PANEL
3	115 V ELECTRICAL DISTRIBUTION PANEL
2	EMERGENCY SHUT-OFF
1	FUEL MANAGEMENT SYSTEM WITH OVERFILL RELAY

DRAWN BY	DATE	CHECKED BY	DATE	APPROVED BY	DATE
D. HIMES	02/17/17	R. GRANTHAM	02/24/17	G. WALKER	02/24/17

Vapor Systems Technologies, Inc. Springfield, Ohio 45506 www.vstcorp.com	
THE INFORMATION ON THIS DOCUMENT IS PROPRIETARY AND IT MAY BE USED AND FOR THE PURPOSE FOR WHICH IT WAS PROVIDED BY VAPOR SYSTEMS TECHNOLOGIES, INC. PROVIDED IT IS NOT REPRODUCED IN ANY MANNER WITHOUT THE WRITTEN PERMISSION OF VAPOR SYSTEMS TECHNOLOGIES, INC.	
SHEET NO.	1 OF 1

Figure 1-5: Example of a GDF Layout



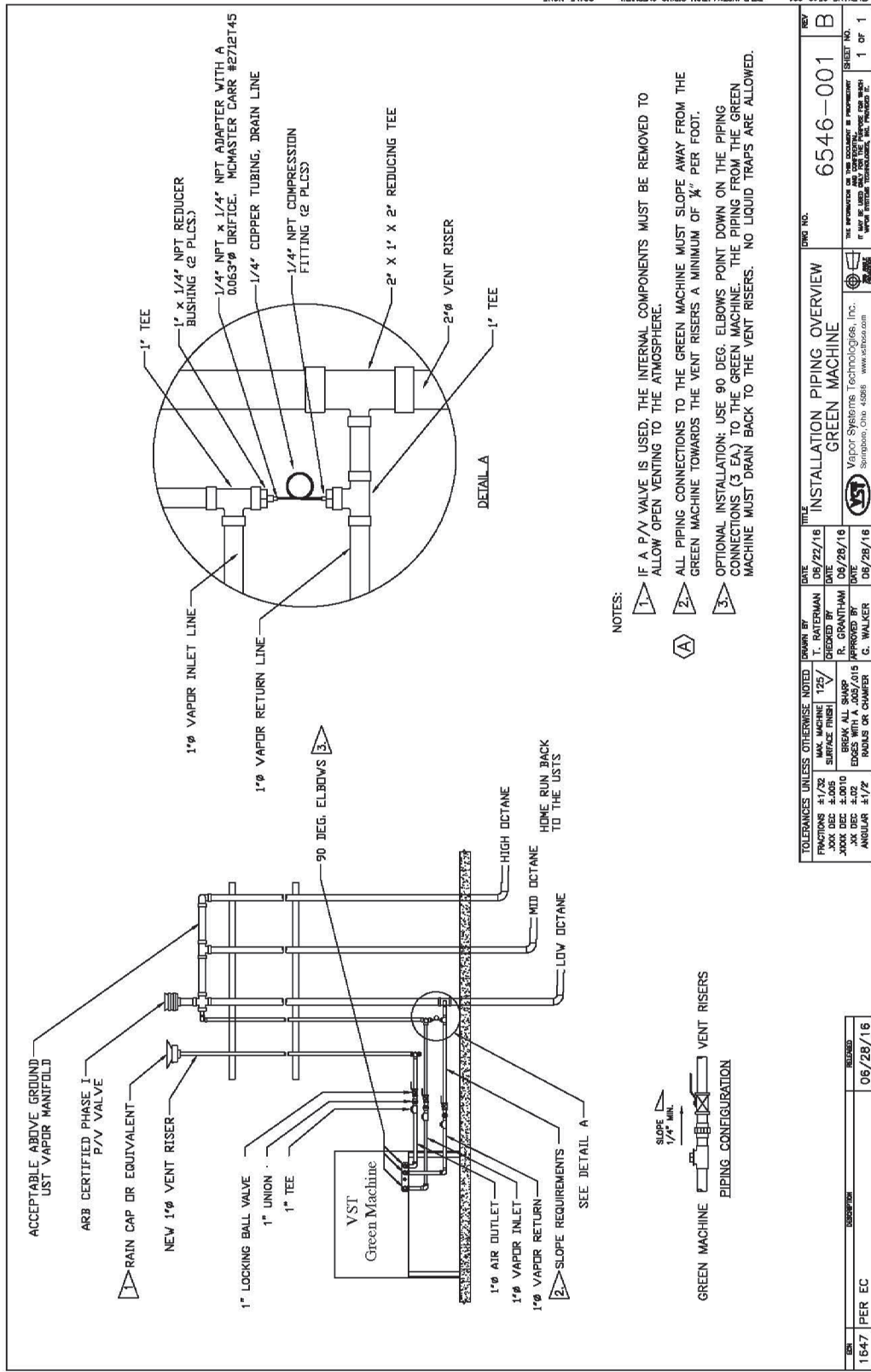
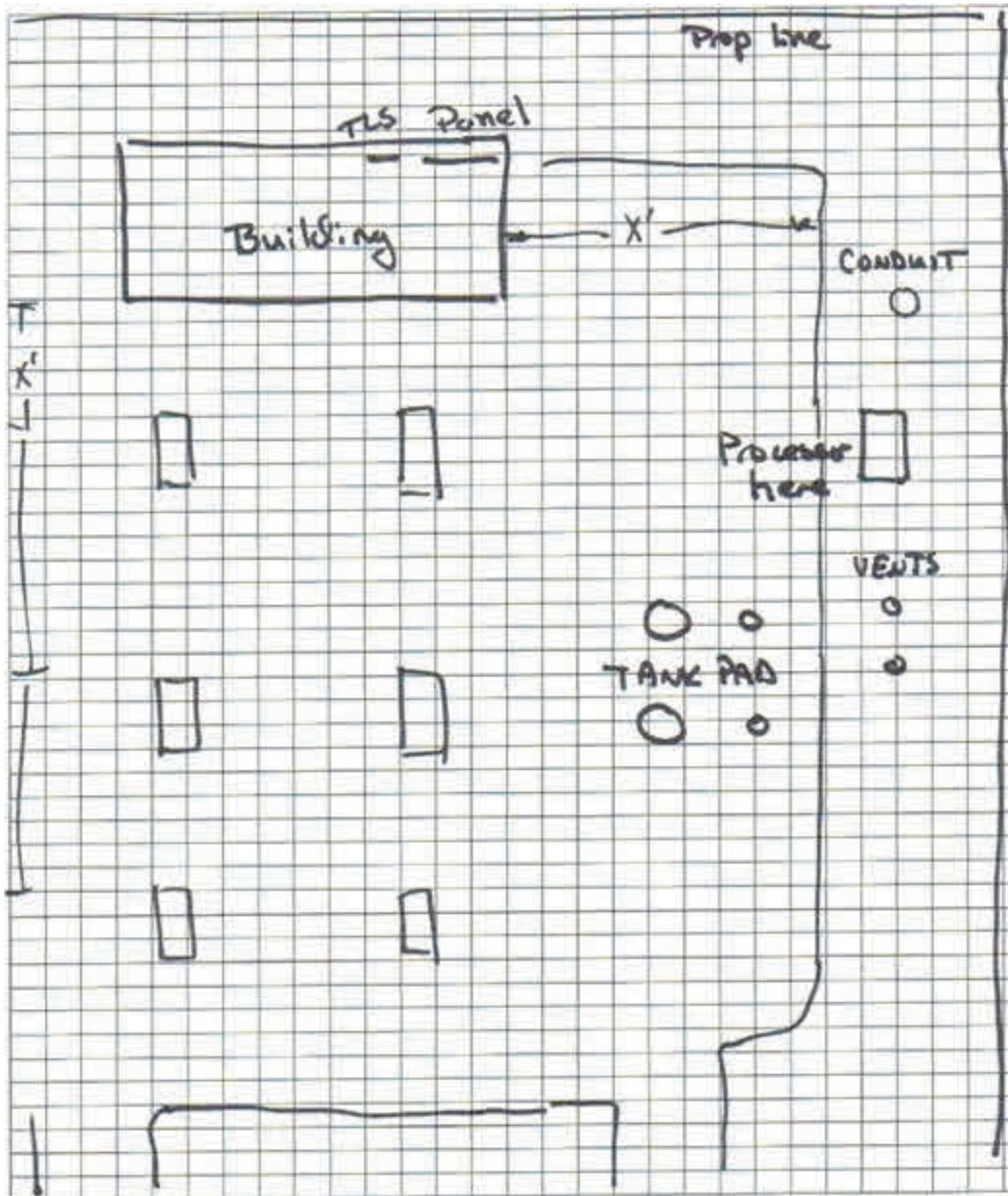

Figure 1-6: Example of a GREEN MACHINE with Vapor Piping Layout



1.16 Sample Sketch





1.16.1 Your Sketch

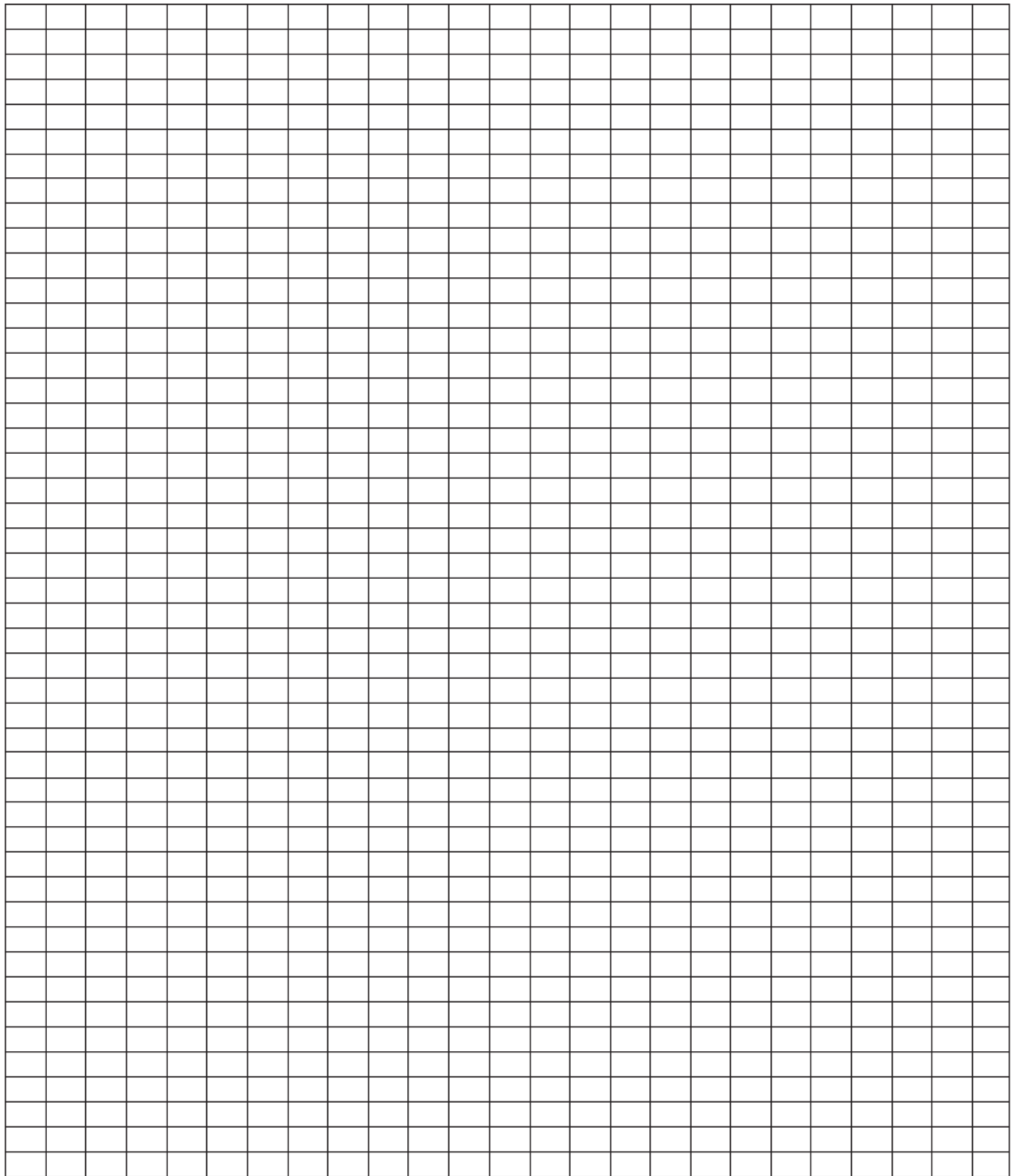



This page left intentionally blank
