

VST Installation Procedure for Phase II Coaxial EVR Balance Nozzle Repair Kits

Part Number Series: VST-FEK-300 (Front End Kit Included VCK and NSA)

VST-VCK-300 (Vapor Collection Kit)

VST-NSA-300 (Nozzle Spout Assembly)



Vapor Systems Technologies, Inc.

650 Pleasant Valley Drive
Springboro, Ohio 45066 (USA)

Toll Free: 1-888-878-4673

Phone: 937-704-9333

Fax: 937-704-9443

www.vsthose.com

Use ONLY on VST Nozzles:

Model #: VST-EVR-NB (G2) and VST-EVR-NB (G2 Rebuilt)

TOOLS

- Torque Wrench
- VST-SRT-200 Torque Wrench Attachment
- Approved Fuel Container
- VST-BPT-100 Nozzle Band Clamp Pincers
- Wide Mouth Funnel
- Petroleum Jelly (or suitable lubricant)

GENERAL INFORMATION

If hanging hardware components are involved in a drive-off or incur other customer abuse, each individual component must be functionally tested prior to customer dispensing activities.

INSTALLATION PREPARATION

This procedure must be followed to ensure leak-proof installation and operation of these nozzles.

1. Turn off and tag the power to the dispenser. Dispenser must be de-energized prior to service to avoid personal injury.
2. Barricade work area to block vehicle access to the dispenser.
3. Close the dispenser shear valve prior to removing hanging hardware (hoses, safety breakaways, and nozzles).
4. Visually inspect and assess the extent of the damage to all hanging hardware components. If the spout is loose at all, replace the entire nozzle spout assembly with VST-NSA-300.
5. Drain liquid product from the hanging hardware set into an approved container prior to replacing any hanging hardware assembly.
6. Remove hanging hardware from the dispenser prior to making replacement component assembly connections. VST recommends connecting the whip hose to the dispenser as the last connection during the hanging hardware assembly.
7. To drain nozzle, engage nozzle interlock:
 - a. Push in face seal on nozzle boot assembly
 - b. Hold the backend of the nozzle over an approved container
 - c. Pull nozzle lever to fully drain the nozzle

VAPOR COLLECTION KIT (VST-VCK-300) REMOVAL

(See Figure 1)

1. Remove large band clamp from the Vapor Collection Assembly with nozzle band clamp pincers (VST-BPT-100).
2. Pull the Vapor Collection Assembly (boot) off of the clamping groove of the nozzle body.

3. Pull Vapor Collection Assembly off of the spout by slightly twisting to go over the spout latch ring.
4. Properly discard the removed components.

Figure 1

Vapor Collection Assembly

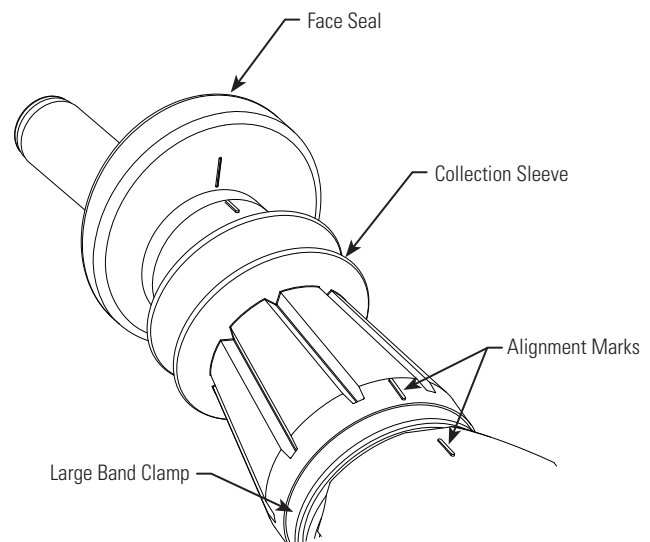

VAPOR COLLECTION KIT (VST-VCK-300) REPLACEMENT

1. Place the large band clamp on the collection sleeve. (See Figure 1)
2. Verify the interlock rod is properly inserted into the hole of the interlock sleeve located around the spout prior to pushing the VCK into place. The rod should be visible through the side hole of the sleeve. (See Figure 2)
3. Slide the VST-VCK-300 over the spout.
4. Align and center all alignment marks on top of the vapor collection kit and nozzle scuff. (See Figure 1)
5. Engage interlock a few times to check for correct alignment and functionality. (See Functional Test 3)
6. Tighten collection band clamp until collection sleeve will not rotate. (See Figure 1)

VST Installation Procedure for Phase II Coaxial EVR Balance Nozzle Repair Kits

Part Number Series: VST-FEK-300 (Front End Kit Included VCK and NSA)

VST-VCK-300 (Vapor Collection Kit)

VST-NSA-300 (Nozzle Spout Assembly)

Figure 2

Nozzle Spout Assembly

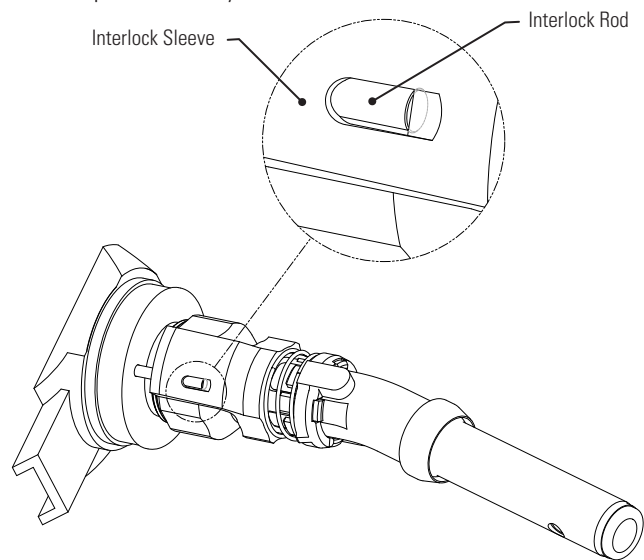

NOZZLE SPOUT ASSEMBLY (VST-NSA-300) REMOVAL

(See Figures 3-4)

1. Remove Vapor Collection Assembly.
2. Hold the interlock rod in place to allow the rod to be disengaged from the hole of the sleeve that is located around the spout nut. (See Figure 3)
3. Slide and rotate the sleeve away from the spout nut and remove the interlock rod. (See Figure 3)
4. Loosen spout nut with the VST-SRT-200 Spout Nut Torque Wrench Attachment. (See Figure 4) **NOTE:** Do not use pipe wrench or locking-type pliers.
5. Once threads are completely disengaged, pull the spout straight out.
6. Properly discard the removed components.

NOZZLE SPOUT ASSEMBLY (VST-NSA-300) REPLACEMENT

(See Figures 5-6)

1. Fuel chamber should remain in the nozzle casting with the vacuum sensing tube hole oriented at the top.
2. If the fuel chamber is pulled out of the nozzle casting:
 - a. Check O-ring for damage.
 - b. Replace O-ring if damaged (check for cuts, nicks, etc.).
 - c. Lubricate O-ring prior to re-assembly.

Figure 3

Interlock Rod Removal

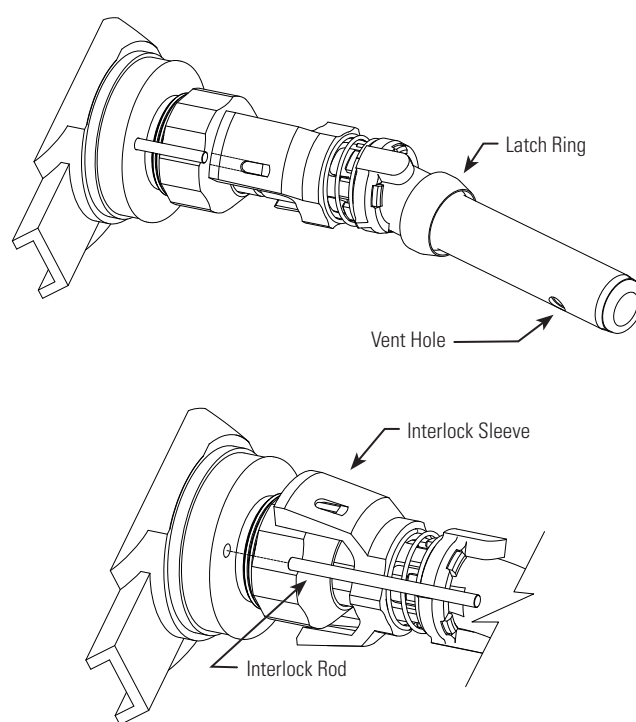
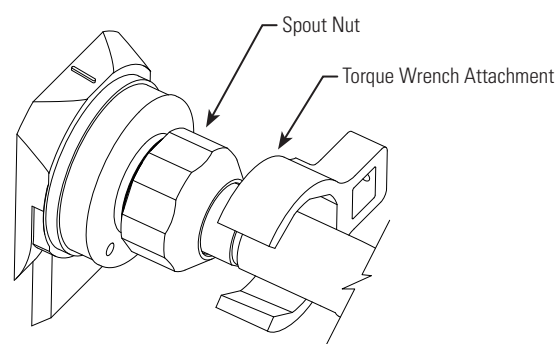

Figure 4

Torque Wrench Attachment



3. Insert fuel chamber into nozzle casting:
 - a. Poppet stem with spring goes through poppet hole in the fuel chamber (center hole).
 - b. Push fuel chamber until it is flush with casting.
 - c. Vacuum sensing tube in the fuel chamber should be oriented at the top.

VST Installation Procedure for Phase II Coaxial EVR Balance Nozzle Repair Kits

Part Number Series: VST-FEK-300 (Front End Kit Included VCK and NSA)

VST-VCK-300 (Vapor Collection Kit)

VST-NSA-300 (Nozzle Spout Assembly)

4. Lightly lubricate ALL O-rings on the spout assembly. **NOTE:** Do not block vacuum sensing-tube hole with lubricant.
5. Align vacuum sensing tube with mating hole in the fuel chamber. (See Figure 5)
6. Align the anti-rotation bump on the spout with the casting notch. Be careful not to damage the spout O-ring. (See Figure 5)
7. Firmly insert spout assembly into the nozzle casting.
8. Apply a dab of Loctite® 271 to the male thread of the nozzle casting. Be careful not to apply the Loctite® so that it would enter into the casting notch. (See Figure 6)
9. Thread spout nut onto the nozzle casting and tighten firmly. Torque to 34 foot-pounds. Use VST-SRT-200 Spout Nut Torque Wrench Attachment in order to apply the appropriate torque. Spout should be tight and not able to rotate. Do not over-tighten the spout nut.
10. After tightening the spout nut, place the interlock rod into the hole of the nozzle casting. Move the sleeve in place so the interlock rod is inserted into the recessed hole on the end of the sleeve. The interlock rod may be compressed into the nozzle to ease the insertion. The interlock rod should be visible through the side hole of the sleeve. (See Figure 2)
11. Re-install the Vapor Collection Kit Assembly per the Vapor Collection Kit Replacement instructions.

FUNCTIONAL TESTS

1. Follow the VST Installation Procedure for each hanging hardware component. (Executive Order Procedures: Section 6, 8 and 9).
2. Purge air from the system by pumping one-tenth (1/10) to two-tenths (2/10) of a gallon of fuel into an approved container. Inspect the nozzle connection for liquid leaks and make proper adjustments at the hose connection if necessary.
3. Check the nozzle shut-off action by dispensing fuel into an approved container at least three times to assure the proper automatic operation of the interlock rod. The fuel flow-rate must be greater than 3 gpm for the automatic shut-off mechanism to operate.

To test, operate the nozzle and submerge the spout tip in fuel until the fuel level covers the vent hole. The main valve of the nozzle automatically shuts off when the liquid covers the

Figure 5
Spout Assembly

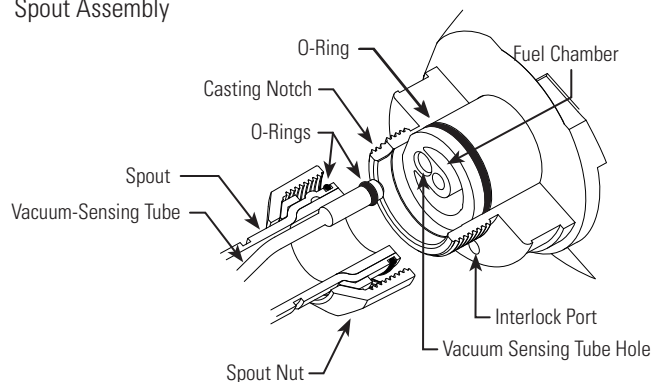
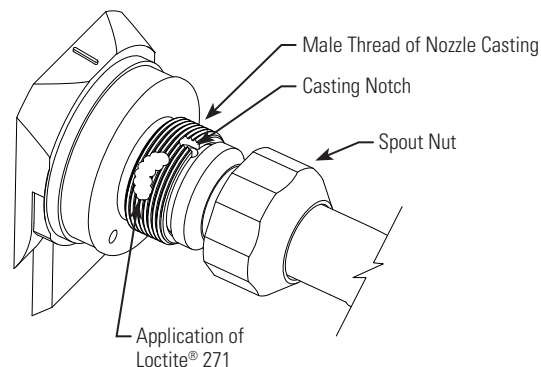

Figure 6
Application of Loctite® 271



vent hole at the end of the spout. The nozzle is not designed to operate on gravity flow. The hold-open latch will disengage automatically when liquid covers the vent hole in the spout. Verify that the fuel flow stops when the nozzle collection sleeve is decompressed (eg. Interlock rod is disengaged). To test that the fuel flow stops, dispense some fuel into an approved container. Slowly remove the nozzle from the container while dispensing fuel. Fuel flow should stop when the nozzle collection sleeve is fully decompressed.

4. Measure the resistance between the dispenser outlet casting and the tip of the nozzle spout. Use an electronic multimeter set on the high range of the ohmmeter function. Resistance should not indicate more than 70,000 ohms per foot of the hose. **Example:** The measured resistance of a 12 foot hose must not exceed 840,000 ohms (840 kilohms).

VST Installation Procedure for Phase II Coaxial EVR Balance Nozzle Repair Kits

Part Number Series: VST-FEK-300 (Front End Kit Included VCK and NSA)

VST-VCK-300 (Vapor Collection Kit)

VST-NSA-300 (Nozzle Spout Assembly)



Vapor Systems Technologies, Inc.

650 Pleasant Valley Drive
Springboro, Ohio 45066 (USA)

Toll Free: 1-888-878-4673

Phone: 937-704-9333

Fax: 937-704-9443

www.vsthose.com

MAINTENANCE

Inspect nozzles daily for damaged components parts: vapor collection sleeve, face seal, interlock rod, spout, lever, lever lock, etc. Damaged components must be replaced. Vent hole at the end of the spout should be clear of debris. The nozzle will not operate properly if vent hole becomes clogged. The nozzle will not function properly without the interlock rod properly engaged. Keep the hose connections tight.

Should there be a drive-off or incidence of customer abuse, follow the initial inspection instructions found in the VST Installation Procedure Section 6. The nozzle should be replaced when damaged. The nozzle is designed and constructed to give lasting service if properly handled and maintained. If for any reason it should need attention, contact your VST distributor for proper disposition.

NOTE

Due to the abuse, misuse, changing gasoline formulas, variation in maintenance practices, environmental conditions, and/or conditions beyond the manufacturer's control, dispensing equipment may need replacement before five (5) years. Inspections and proper maintenance procedures should be followed by the station manager to determine if replacement is required before five (5) years.

WARNING

Unauthorized rebuilding or modifying of nozzles voids ALL approvals and warranties. VST products must be used in compliance with applicable federal, state, and local laws and regulations. If local regulatory codes prohibit use of the nozzle's hold open clip, it must be removed prior to nozzle installation. Remove the nozzle to a safe work area.

Place the nozzle on a flat surface. Locate the alloy rivet securing the hold-open clip, and spring in the nozzle's handle. Use a drill with a 3/16" (5 mm) drill bit, drill out the rivet securing the hold-open clip, and discard the clip, spring, and all other rivet debris.